



Prospectus  
Dated : August 29, 2008

## CHEMCEL BIOTECH LIMITED

(Our Company was originally incorporated as "Chemcel Products Limited" on September 29, 1995 under the Companies Act, 1956 in the State of Andhra Pradesh, India. The name of our Company was changed to Chemcel Bio-Tech Limited w.e.f. January 4, 2001)

**Registered Office:** 16-130/12, JRD Tata Industrial Estate, Auto Nagar, Kanuru, Vijayawada - 520007. The registered office of our Company was shifted from Plot No. E-32, 100 Feet Road, Auto Nagar, Vijayawada - 520007 to the present address mentioned above w.e.f. February 17, 1998.

**Tel:** +91-0866-2540355; 2544996. **Fax:** +91-0866 - 2545437; **Email:** ipo@chemcelbiotechltd.com; **Website:** www.chemcelbiotechltd.com

**Contact Person:** Mr. Shaik Rahmatullah - Company Secretary & Compliance Officer; **E-mail:** complianceofficer@chemcelbiotechltd.com

**ISSUE OF 1,54,00,000 EQUITY SHARES OF Rs. 10/- EACH AT A PRICE OF Rs.16/- PER EQUITY SHARE (INCLUDING A PREMIUM OF Rs.6/- PER EQUITY SHARE) OF CHEMCEL BIOTECH LIMITED (HEREINAFTER REFERRED TO AS THE "COMPANY" OR "ISSUER") FOR CASH AGGREGATING TO Rs.2464 LAKHS ("ISSUE"). THE ISSUE COMPRISES OF CONTRIBUTION BY PROMOTERS OF 16,00,000 EQUITY SHARES OF Rs. 10/- EACH AT A PRICE OF Rs.16/- PER EQUITY SHARE FOR CASH AGGREGATING TO Rs.256 LAKHS ("PROMOTER'S CONTRIBUTION PORTION"), 10,00,000 EQUITY SHARES OF Rs.10/- EACH RESERVED FOR ELIGIBLE EMPLOYEES OF THE ISSUER COMPANY ON COMPETITIVE BASIS AT A PRICE OF Rs.16/- AGGREGATING TO Rs.160 LAKHS (HEREINAFTER REFERRED TO AS EMPLOYEE RESERVATION PORTION ) AND THE NET ISSUE TO THE PUBLIC OF 1,28,00,000 EQUITY SHARES OF Rs. 10/- EACH AT A PRICE OF Rs.16/- PER EQUITY SHARE FOR CASH AGGREGATING TO Rs.2048 LAKHS ("NET ISSUE TO PUBLIC") THE NET ISSUE TO THE PUBLIC WOULD CONSTITUTE 49.39% OF THE FULLY DILUTED POST ISSUE PAID UP CAPITAL OF OUR COMPANY.**

**ISSUE PRICE : Rs.16 PER EQUITY SHARE OF FACE VALUE OF Rs.10/- EACH**

**THE ISSUE PRICE IS 1.6 TIMES OF THE FACE VALUE OF EQUITY SHARE**

### RISKS IN RELATION TO THE FIRST ISSUE

This being the first issue of the Equity Shares of Chemcel Biotech Limited ("our Company"), there has been no formal market for the Equity Shares of our Company. The Face value of the Equity Shares is Rs.10/- per share and the issue price is 1.6 times of the face value. The Issue price (as has been determined and justified by the Lead Merchant Banker and the issuer Company as stated under "Basis for Issue Price" on page no.40 of the Offer Document) should not be taken to be indicative of the market price of the Equity Shares after the Equity Shares are listed. No assurance can be given regarding active or sustained trading in the shares of Chemcel Biotech Limited or regarding the price at which the Equity Shares will be traded after listing.

### GENERAL RISK

Investments in equity and equity related securities involve a degree of risk and investors should not invest any funds in this Issue unless they can afford to take the risk of losing their investment. Investors are advised to read the risk factors carefully before taking an investment decision in this Issue. For taking an investment decision, investors must rely on their own examination of our Company and the Issue including the risks involved. The Equity Shares offered in the Issue have not been recommended or approved by the Securities and Exchange Board of India (SEBI), nor does SEBI guarantee the accuracy or adequacy of this Prospectus. **Specific attention of the investors is invited to the section titled 'Risk Factors' beginning on page no. xii of this Prospectus.**

### ISSUER'S ABSOLUTE RESPONSIBILITY

Our Company, having made all reasonable inquiries, accepts responsibility for and confirms that this Prospectus contains all information with regard to our Company and the Issue, which is material in the context of the Issue, that the information contained in this Prospectus is true and correct in all material aspects and is not misleading in any material respect, that the opinions and intentions expressed herein are honestly held and that there are no other facts, the omission of which makes this Prospectus as a whole or any of such information or the expression of any such opinions or intentions misleading in any material respect.

### LISTING

The Equity Shares offered through this Prospectus are proposed to be listed on Bombay Stock Exchange Limited (BSE) (Designated Stock Exchange) The in-principle approval of BSE for the listing of our Equity Shares has been received vide its letter no.DCS/IPO/SI/IPO-IP/1823/2007 dated February 8, 2008.

### IPO GRADING

This Issue has been graded by ICRA Ltd and has been assigned the "IPO Grade 1" indicating poor fundamentals, vide its letter ref: ICRA/CBL/2008-09/2006 dated June 25, 2008 and revalidated for a period of 6 months vide its letter dated ICRA/CBL/2008-09/2208 dated August 22, 2008. For further details please refer to page no. 15 of this Prospectus.

### LEAD MANAGER TO THE ISSUE



**AllBank Finance Ltd**  
(Wholly owned Subsidiary of Allahabad Bank)  
**SEBI Regn.no.INM00006609**  
Allahabad Bank Building 2<sup>nd</sup> floor  
37 Mumbai Samachar Marg  
Mumbai - 400 023.  
Tel : +91 - 22 - 22677552 / 22626283  
Fax: +91 - 22 - 22677552  
Email: chemcel\_ipo@allbankfinance.com  
Website: www.allbankfinance.com  
Contact Person : Mr.K.Shiv Shankar/Ms. Padma

### REGISTRAR TO THE ISSUE



**Bigshare Services Private Limited,**  
**SEBI Regn.no.INR000001385**  
E-2, Ansa Industrial Estate,  
Sakivihar Road,Saki Naka,  
Andheri East,  
Mumbai - 400 072.  
Tel: +91 - 22 - 40430200 / 28470652  
Fax: +91 - 22 - 2847 5207  
Email: ipo@bigshareonline.com  
Website: www.bigshareonline.com  
Contact Person:Mr Ashok Shetty / Mr. N.V.K. Mohan

### ISSUE SCHEDULE

**ISSUE OPENS ON : TUESDAY, SEPTEMBER 09, 2008**

**ISSUE CLOSSES ON : FRIDAY, SEPTEMBER 12, 2008**



## TABLE OF CONTENTS

S. NO.	PARTICULARS	PAGE. NO.
<b>I</b>	<b>GENERAL</b>	<b>i</b>
	DEFINITIONS, ABBREVIATIONS & TECHNICAL TERMS	i
<b>II</b>	<b>RISK FACTORS</b>	<b>x</b>
	1. CERTAIN CONVENTIONS; USE OF MARKET DATA	x
	2. FORWARD LOOKING STATEMENTS	xi
	3. RISK FACTORS	xii
<b>III</b>	<b>INTRODUCTION</b>	<b>1</b>
	1. SUMMARY	1
	2. THE ISSUE	7
	3. SUMMARY OF FINANCIAL/OPERATING DATA	8
	4. GENERAL INFORMATION	12
	5. CAPITAL STRUCTURE	19
	6. OBJECTS OF THE ISSUE	28
	7. BASIC TERMS OF THE ISSUE	38
	8. BASIS FOR ISSUE PRICE	40
	9. STATEMENT OF TAX BENEFITS	43
<b>IV</b>	<b>ABOUT OUR COMPANY</b>	<b>47</b>
	1. INDUSTRY OVERVIEW	47
	2. OUR BUSINESS	67
	3. KEY INDUSTRY REGULATIONS AND POLICIES	85
	4. HISTORY AND CERTAIN CORPORATE MATTERS	88
	5. MANAGEMENT	92
	6. PROMOTERS	102
	7. CURRENCY OF PRESENTATION	104
	8. RELATED PARTY TRANSACTIONS	105
	9. DIVIDEND POLICY	106
<b>V</b>	<b>FINANCIAL INFORMATION OF OUR COMPANY</b>	<b>107</b>
	1. FINANCIAL STATEMENTS OF OUR COMPANY	107
	2. FINANCIAL STATEMENTS OF OUR SUBSIDIARY	121
	3. MANAGEMENT'S DISCUSSION AND ANALYSIS OF FINANCIAL CONDITION & RESULTS OF OPERATIONS	143
<b>VI</b>	<b>LEGAL AND OTHER INFORMATION</b>	<b>148</b>
	1. OUTSTANDING LITIGATIONS AND MATERIAL DEVELOPMENTS	148
	2. GOVERNMENT APPROVALS/LICENSING ARRANGEMENTS	151
<b>VII</b>	<b>OTHER REGULATORY AND STATUTORY DISCLOSURES</b>	<b>155</b>
<b>VIII</b>	<b>ISSUE RELATED INFORMATION</b>	<b>163</b>
	1. TERMS OF THE ISSUE	163
	2. ISSUE STRUCTURE	166
	3. ISSUE PROCEDURE	168
<b>IX</b>	<b>MAIN PROVISIONS OF THE ARTICLES OF ASSOCIATION</b>	<b>189</b>
<b>X</b>	<b>MATERIAL CONTRACTS AND DOCUMENTS FOR INSPECTION</b>	<b>215</b>
<b>XI</b>	<b>DECLARATION</b>	<b>217</b>



## SECTION - I

### DEFINITIONS, ABBREVIATIONS & TECHNICAL TERMS

#### General terms

Term	Description
<b>Act</b>	The Companies Act ,1956
<b>“Chemcel Biotech”, “Company”, “CBL”, “Chemcel Biotech Ltd”</b>	Unless the context otherwise requires, refers to Chemcel Bio-Tech Limited, a company incorporated under the Companies Act, 1956
<b>FEMA</b>	Foreign Exchange Management Act, 1999, as amended, and the rules and regulations framed thereunder.
<b>HUF</b>	Hindu Undivided Family
<b>NAV</b>	Net Asset Value
<b>OCB/ Overseas Corporate Bodies</b>	Overseas Corporate Body means and includes an entity defined in clause (xi) of Regulation 2 of the Foreign Exchange Management (Withdrawal of General Permission to Overseas Corporate Bodies (OCB's) Regulations 2003 and which was in existence on the date of the commencement of these Regulations and immediately prior to such commencement was eligible to undertake transactions pursuant to the general permission granted under the Regulations. OCBs are not allowed to invest in this Issue.
<b>PAN</b>	Permanent Account Number
<b>PAT</b>	Profit After Tax
<b>RONW</b>	Return on Net worth
<b>SCRR</b>	Securities Contracts (Regulations) Rules, 1957 as amended
<b>SSI</b>	Small Scale Industry
<b>SEBI</b>	Securities and Exchange Board of India constituted under the SEBI Act
<b>SEBI Act</b>	Securities and Exchange Board of India Act, 1992 as amended
<b>SEBI (DIP )Guidelines</b>	SEBI (Disclosure and Investor Protection) Guidelines, 2000 issued by SEBI on January 27, 2000, as amended, including instructions and clarifications issued by SEBI from time to time

#### Issue related terms

Term	Description
<b>Allotment</b>	Unless the context otherwise requires, issue of equity shares pursuant to this issue
<b>Allottee</b>	The successful applicant to whom the Equity Shares are being / or have been issued or transferred
<b>Applicant</b>	Any prospective investor who makes an application pursuant to the terms of this Prospectus
<b>Articles/Articles of Association/AoA</b>	Articles of Association of Chemcel Biotech Limited



<b>Application Form</b>	The form in terms of which the Investors shall apply for equity shares of our Company
<b>Auditors</b>	The Statutory Auditors of our Company, Mr.T.Nehru, Chartered Accountant, Vijayawada.
<b>Bankers to the Issue</b>	<b>Standard Chartered Bank, HDFC Bank Ltd , and Axis Bank Limited</b>
<b>Board/Board of Directors</b>	The Board of Directors of Chemcel Biotech Limited or a committee thereof
<b>BSE</b>	Bombay Stock Exchange Limited , Mumbai
<b>CDSL</b>	Central Depository Services (India) Limited
<b>Co-Lead Manager</b>	Ashika Capital Limited, Mumbai.
<b>Compliance Officer</b>	Mr. Shaik Rahmatullah, Company Secretary
<b>Depositories Act</b>	Depositories Act, 1996 as amended
<b>Depository</b>	A Depository registered with SEBI under the SEBI (Depositories & Participant) Regulations, 1996 as amended
<b>Depository Participant</b>	Depository Participant as defined under the Depositories Act
<b>Designated Stock Exchange</b>	Bombay Stock Exchange Limited, Mumbai
<b>Director(s)</b>	Director(s) of Chemcel Biotech Ltd unless otherwise specified
<b>Eligible Employee</b>	Permanent employees of our Company who are Indian nationals based in India as of August 29,2008 and are present in India on the date of submission of the Application Form. A director of our Company, whether a whole time director, except any Promoters or members of the Promoter group, part- time director or otherwise as of August 29,2008 and based and present in India as on the date of submission of Application Form.
<b>Employee Reservation portion</b>	The portion of the issue being a maximum of 10,00,000 Equity Shares available for allotment to eligible employees of our Company on competitive basis.
<b>Equity Shares</b>	Equity Shares of our Company face value of Rs.10/- each unless otherwise specified in the context thereof
<b>Equity Shareholders</b>	Persons holding equity shares of our Company unless otherwise specified in the context thereof
<b>First Applicant</b>	The applicant whose name appears first in the Application Form
<b>Foreign Institutional Investors</b>	Foreign Institutional Investor (as defined under FEMA (Transfer or Offer of Security by a Person Resident outside India) Regulations, 2000) registered with SEBI under applicable laws in India
<b>Financial year/FY</b>	Period of twelve months ended 31 <sup>st</sup> March of that particular year
<b>GIR</b>	General Index Registry Number
<b>GAAP</b>	Generally Accepted Accounting Practices



<b>ICRA</b>	ICRA Limited, with its registered office located at 1105, Kailash Building Eleventh Floor, 26, Kasturba Gandhi Marg, New Delhi 110 001, being the IPO grading agency appointed pursuant to Clause 2.5A of the SEBI DIP Guidelines
<b>Issue price</b>	The issue price of Rs 16 per equity share of face value of Rs 10 each at which Equity Shares will be issued and allotted in terms of the Prospectus. The Issue Price has been decided by the Company in consultation with the LeadManagers
<b>Issue Size</b>	Issue of 1,54,00,000 equity shares of Rs. 10/- each at a price of Rs.16/- per equity share (including a premium of Rs.6/- per equity share) of Chemcel Biotech limited (hereinafter referred to as “our Company” or “Issuer”) for cash aggregating to Rs. 2464 Lakhs (“Issue”). The issue comprises a contribution by Promoters, of 16,00,000 equity shares of Rs. 10/- each at a price of Rs.16/- per equity share for cash aggregating to Rs. 256 Lakhs (“Promoter’s Contribution Portion”), 10,00,000 equity shares of Rs. 10 each reserved for Eligible Employees on competitive basis at a price of Rs. 16/- ( hereinafter referred to as employee reservation portion ) and the net issue to the public of 128,00,000 equity shares of Rs. 10/- each at a price of Rs. 16/- per equity share for cash aggregating to Rs.2048 Lakhs (“Net Issue to Public”) The Net Issue to the Public would constitute 49.39% of the fully diluted post issue paid up capital of our Company . The issue price is 1.6 times of the face value of the equity share.
<b>Issue Opening date</b>	The date on which the Issue opens for subscription
<b>Issue closing date</b>	The date on which the Issue closes for subscription
<b>Issue Period</b>	The period between the Issue opening & Issue closing date and includes both these dates
<b>Issuer</b>	Chemcel Biotech Limited
<b>I T Act</b>	The Income Tax Act, 1961, as amended
<b>Lead Manager</b>	Allbank Finance Limited , Mumbai
<b>Memorandum/Memorandum of Association/MOA</b>	The Memorandum of Association of Chemcel Biotech Ltd.
<b>Net Issue to the Public</b>	The Issue less the Promoters Contribution and Employee Reservation Portion
<b>NRI/Non-Resident Indian</b>	Non-Resident Indian, is a person resident outside India, as defined under FEMA and who is a citizen of India or a Person of Indian Origin under FEMA (Transfer or Offer of Security by a Person Resident Outside India) Regulations, 2000
<b>NSDL</b>	National Securities Depository Limited
<b>PAN</b>	Permanent Account Number
<b>Prospectus</b>	Refers to this document, in terms of which the present Issue of Equity Shares is proposed
<b>Promoters</b>	Mr. Kanuparthi Balakrishna Rao, Mr. Kanuparthi Trinadha Vijaya Kumar and Mr. Kanuparthi Chandra Shekar Prasad
<b>QCD</b>	Quality Control Department



<b>Qualified Institutional Buyers or QIBs</b>	Qualified Institutional Buyers: a. Public financial institution as defined in section 4A of the Companies Act, 1956;b. Scheduled Commercial banks;c. Mutual funds;d. Foreign Institutional Investor registered with SEBI;e. Multilateral and Bilateral development financial institutions;f. Venture Capital funds registered with SEBI;g. Foreign Venture Capital investors registered with SEBI;h. State Industrial Development Corporations;i. Insurance Companies registered with the Insurance Regulatory and Development Authority (IRDA);j. Provident Funds with minimum corpus of Rs. 2500 lakhsk. Pension Funds with minimum corpus of Rs. 2500 lakhsl. National Investment Fund set up by Resolution F.NO. 2/3/2005 DD 11 Dated Nov.23,2005
<b>RBI</b>	Reserve Bank of India
<b>Registered Office of our Company</b>	16-130/12, JRD Tata Industrial Estate, 3rd Cross Road Extension, Kanuru, Vijayawada 520007
<b>Registrar/Registrar to the Issue</b>	Bigshare Services Pvt. Limited
<b>RoC</b>	Registrar of Companies, Andhra Pradesh, 2 <sup>nd</sup> Floor, Kendriya Sadan, Sultan Bazar, Hyderabad 500195
<b>Retail Applicants/Retail Individual Applicants</b>	Retail Individual Applicants ( <i>including HUFs</i> ) applying through their karta) who have applied for Equity Shares for an amount less than or equal to Rs.100,000 in any of the application in the Issue.
<b>Stock Exchange</b>	BSE
<b>US GAAP</b>	Generally Accepted Accounting Practices of United States of America

**Company/Industry-related terms**

<b>Term</b>	<b>Description</b>
<b>Agrochemicals</b>	Chemicals used in agriculture for combating pests
<b>Bio-Diesel</b>	Oil extracted from the seeds
<b>CIB</b>	Central Insecticide Board
<b>Formulations</b>	Mixture of various chemicals as defined by the CIB
<b>IEM</b>	Industrial Entrepreneur Memorandum
<b>PCB</b>	Pollution Control Board
<b>TPD</b>	Tons Per Day
<b>Abbreviations</b>	
<b>A/C</b>	Account
<b>AGM</b>	Annual General Meeting
<b>AS</b>	Accounting Standards as issued by the Institute of Chartered Accountants of India
<b>ALLBANK</b>	AllBank Finance Limited, Mumbai , Lead Manager to the issue
<b>ASHIKA</b>	Ashika Capital Limited, Co-Lead Managers to the Issue



<b>APSRTC</b>	Andhra Pradesh State Road Transport Corporation
<b>AY</b>	Assessment Year
<b>BIS</b>	Bureau of Indian Standards
<b>BSE</b>	Bombay Stock Exchange Limited
<b>BSS</b>	Bigshare Services Private Limited, Registrar to the Issue
<b>BPCL</b>	Bharat Petroleum Corporation Limited
<b>BPLR</b>	Bank Prime Lending Rate
<b>CAGR</b>	Compounded Annual Growth Rate
<b>CDSL</b>	Central Depository Services(India) Limited
<b>CIN</b>	Company Identification Number
<b>CSIR</b>	Council of Scientific & Industrial Research
<b>CSMCRI</b>	Central Salt and Marine Chemicals Research Institute, Bhavnagar
<b>DBT</b>	Department of Biotechnology
<b>DDT</b>	Dichloro-Diphenyl-Trichloroethane
<b>DIN</b>	Director's Identification Number
<b>EBITD</b>	Earnings before interest, tax and depreciation
<b>EC</b>	Emulsifiable Concentrate / European community /European Commission
<b>EGM</b>	Extra-ordinary General Meeting
<b>EU</b>	European union
<b>EPS</b>	Earnings Per Share
<b>FIIs</b>	Foreign Institutional Investors registered with SEBI under applicable laws
<b>FY</b>	Financial year ended 31 <sup>st</sup> March
<b>GDP</b>	Gross Domestic Product
<b>GIR Number</b>	General Index Registry Number
<b>HDPE</b>	High Density Poly Ethylene
<b>HPCL</b>	Hindustan Petroleum Corporation Limited
<b>HSD</b>	High Speed Diesel
<b>HUF</b>	Hindu Undivided Family
<b>IIP</b>	Indian Institute of Petroleum , Dehradun
<b>IITs</b>	Indian Institutes of Technology
<b>IPO</b>	Initial Public Offering
<b>IOC</b>	Indian Oil Corporation
<b>INR/Rs.</b>	Indian Rupees
<b>Mb/d</b>	Million Barrels per day
<b>MMT</b>	Million Metric Tons



<b>MMSCMD</b>	Million Metric Standard Cubic Meter Per Day
<b>MOU</b>	Memorandum of Understanding
<b>N.A</b>	Not applicable
<b>NBB</b>	National Biodiesel Board
<b>NBC</b>	National Biofuel Centre
<b>NBRI</b>	National Botanical Research Institute
<b>NGO</b>	Non- Government Organisation
<b>NOVODB</b>	National Oilseeds and Vegetable Oils Development Board
<b>NRE Account</b>	Non-Resident External Account
<b>NRI</b>	Non-Resident Indian
<b>NSDL</b>	National Securities Depository Ltd.
<b>OECD</b>	Organization for Economic Co-operation and Development
<b>PAN</b>	Permanent Account Number
<b>PAT</b>	Profit After Tax
<b>PBT</b>	Profit Before Tax
<b>PBDIT</b>	Profit before Depreciation, Interest and Tax
<b>PBIT</b>	Profit before Interest and Tax
<b>PCRA</b>	Petroleum Conservation Research Association
<b>P/E Ratio</b>	Price/Earnings Ratio
<b>PRI</b>	Panchayati Raj Institutions
<b>QIB</b>	Qualified Institutional Buyer
<b>R&amp;D</b>	Research and Development
<b>RBI</b>	Reserve Bank of India
<b>Sec</b>	Section
<b>TBO</b>	Tree Borne Oilseeds
<b>TNW</b>	Tangible net worth
<b>TPD</b>	Tons per day
<b>UNFCCC</b>	United Nations Framework Convention on Climate Change
<b>USA</b>	United States of America
<b>USAID</b>	US Agency for International Development
<b>VAT</b>	Value Added Tax
<b>WDP</b>	Water Dispersible Powder





## Glossary used in Bio Diesel Industry

<b>Algae</b>	Algae are primitive plants, usually aquatic, capable of synthesising their own food by photosynthesis. Algae is currently being investigated as a possible <b>feedstock</b> for producing biodiesel
<b>B100.</b>	B100 is another name for pure <b>biodiesel</b>
<b>Biobutanol</b>	Biobutanol is an advantaged biofuel that offers a number of benefits over conventional biofuels. For example, biobutanol has an energy content closer to that of petroleum so consumers face less of a compromise on fuel economy. It can easily be added to conventional petrol due to low vapour pressure and can be blended at higher concentrations than bioethanol for use in standard vehicle engines. DuPont and BP are working together on a major project to produce biobutanol
<b>Biodiesel</b>	Biodiesel is a biofuel produced from various feedstocks including vegetable oils (such as <b>oilseed</b>
<b>Biofuel</b>	The term biofuel applies to any solid
<b>Biomass</b>	Biomass is biological material
<b>Bioreactor</b>	A bioreactor is a vessel in which a chemical process occurs. This usually involves organisms or biochemically active substances derived from such organisms
<b>BTL</b>	BTL, or biomass-to-liquid, is a multi-step process which converts biomass into liquid biofuels. BTL is also referred to as second generation biodiesel production. There are many different methods of BTL, but many processes include <b>Fischer-Tropsch</b> , hydrogenation or <b>pyrolysis</b> .
<b>By-product</b>	A by-product is a substance, other than the principal product, generated as a consequence of creating a biofuel. For example, a by-product of biodiesel production is <b>glycerine</b> and a by-product of bioethanol production is <b>DDGS</b>
<b>Catalyst</b>	A catalyst is a substance that increases the rate of a chemical reaction, without being consumed or produced by the reaction. <b>Enzymes</b> are catalysts for many biochemical reactions.
<b>Cetane number</b>	The cetane number is a measure of biodiesel's combustion quality
<b>Conventional biofuels</b>	Conventional biofuels such as bioethanol and biodiesel are typically made from corn, sugarcane and beet, wheat or oilseed crops such as soy and rape.
<b>Emissions</b>	: Emissions are classed as any waste substances released into the air or water.
<b>Enzyme</b>	: An enzyme is a protein or protein-based molecule that speeds up chemical reactions occurring in living things. Enzymes act as catalysts for a single reaction, converting a specific set of reactants into specific products.



<b>FAME</b>	FAME, or fatty acid methyl ester can be created by a catalysed reaction between fatty acids and <b>methanol</b> . The molecules in biodiesel are primarily FAMEs, usually obtained from vegetable oils by <b>transesterification</b> .
<b>Fatty acid:</b>	A fatty acid is a carboxylic acid (an acid with a -COOH group) with long hydrocarbon side chains. Feedstocks are first converted to fatty acids and then to biodiesel
<b>Feedstock</b>	A feedstock is any biomass resource destined for conversion to energy or biofuel. For example, corn is a feedstock for ethanol production, soybean oil may be a feedstock for biodiesel and cellulosic biomass has the potential to be a significant feedstock source for biofuels.
<b>Fischer-Tropsch</b>	Fischer-Tropsch is one method of producing biodiesel, from natural gas or syngas from gasified coal or biomass
<b>Fuel</b>	A fuel is described as any material with one type of energy that can be converted to another usable energy.
<b>Glycerine</b>	Glycerine is a liquid <b>by-product</b> of biodiesel production. Glycerine is used in the manufacture of dynamite, cosmetics, liquid soaps, inks, and lubricants.
<b>GTL</b>	GTL, or gas to liquid, is a refinery process which converts natural gas into longer-chain hydrocarbons. Gas can be converted to liquid fuels via a direct conversion or using a process such as <b>Fischer-Tropsch</b> .
<b>Jatropha</b>	Jatropha is a non-edible evergreen shrub found in Asia, Africa and the West Indies. Its seeds contain a high proportion of oil which can be used for making biodiesel.
<b>Methanol</b>	Methanol is an alcohol containing one carbon atom per molecule, generally made from natural gas, with about half the energy density of petroleum. Methanol is used as a component in the <b>transesterification</b> of triglycerides to give a form of biodiesel.
<b>MTBE</b>	MTBE, or methyl tertiary-butyl ether, is created from methanol and can increase octane and decrease the volatility of petroleum. It is often used as a petroleum additive because it raises the oxygen content of the fuel.
<b>Nitrogen Oxides</b>	Nitrogen Oxides (NOx) are a product of photochemical reactions of nitric oxide in ambient air, and are one type of emission produces from fuels.
<b>Palm oil</b>	Palm oil is a form of vegetable oil obtained from the fruit of the oil palm tree. It is a widely used feedstock The palm oil and palm kernel oil are composed of fatty acids, esterified with glycerol just like any ordinary fat. Palm oil is a widely used feedstock for traditional biodiesel production.
<b>Petroleum</b>	Petroleum refers to any petroleum-based substance comprising of a complex blend of hydrocarbons derived from crude oil through the process of separation, conversion, upgrading, and finishing, including motor fuel, jet oil, lubricants, petroleum solvents, and used oil.



<b>Pyrolysis</b>	Pyrolysis is one method of converting biomass into biodiesel, using heat.
<b>Pyrolysis oil</b>	Pyrolysis oil is a bio-oil produced by fast pyrolysis of biomass. It is a dark brown, mobile liquid containing much of the energy content of the original biomass, with a heating value about half that of conventional fuel oil. Conversion of raw biomass to pyrolysis oil represents a considerable increase in energy density and it can thus represent a more efficient form in which to transport it.
<b>Rapeseed</b>	Rapeseed ( <i>Brassica napus</i> ), also known as rape, oilseed rape or (one particular artificial variety) canola, is a bright yellow flowering member of the family Brassicaceae (mustard or cabbage family). Rapeseed is a tradition feedstock used for biodiesel production.
<b>RTFO</b>	RTFO, or the Renewable Transport Fuels Obligation, is a UK policy that places an obligation on fuel suppliers to ensure that a certain percentage of their aggregate sales is made up of biofuels. The effect of this will be to require 5% of all UK fuel sold on UK forecourts to come from a renewable source by 2010.
<b>Second generation biofuels –</b>	Although definitions vary, second generation biofuels are usually considered to be biofuels produced from biomass or non-edible feedstocks.
<b>Syngas</b>	Syngas is a mixture of carbon monoxide (CO) and hydrogen (H <sub>2</sub> ) which is the product of high temperature gasification of organic material such as biomass. Following clean-up to remove any impurities such as tars, synthesis gas (syngas) can be used to synthesise organic molecules such as synthetic natural gas (SNG - methane (CH <sub>4</sub> )) or liquid biofuels such as synthetic diesel (via <b>Fischer-Tropsch</b> synthesis).
<b>Tallow</b>	Tallow is another name for animal fat, which can be used as a feedstock for biodiesel production.
<b>Transesterification</b>	The name biodiesel has been given to transesterified vegetable oil to describe its use as a diesel fuel. The transesterification process involves mixing at room temperature methanol (50% excess) with NaOH (100% excess), then mixing vigorously with vegetable oil and letting the glycerol settle (about 15% of the biodiesel mix). The supernatant is biodiesel and contains a mixture of methylated fatty acids and methanol



## SECTION II : RISK FACTORS

### 1. CERTAIN CONVENTIONS; USE OF MARKET DATA

In the Prospectus, unless the context otherwise requires, all references to one gender also refers to the other gender.

Unless the context otherwise requires, the financial data in this Prospectus is derived from our financial statements prepared and restated in accordance with Indian GAAP and included in this Prospectus. Accordingly, financial information relating to us is presented for the years ended March 31 2004, 2005, 2006, 2007 and 2008. Our fiscal year commences on April 1 and ends on March 31. In this Prospectus, any discrepancies in any table between the total and the sums of the amounts listed are due to rounding-off.

There are significant differences between Indian GAAP and U.S. GAAP, accordingly, the degree to which the Indian GAAP financial statements included in this Prospectus will provide meaningful information, is entirely dependent on the reader's level of familiarity with Indian accounting practices. Any reliance by persons not familiar with Indian accounting practices on the financial disclosures presented in this Prospectus should accordingly be limited. We have not attempted to explain those differences or quantify their impact on the financial data included herein, and we urge you to consult your own advisors regarding such differences and their impact on our financial data.

For additional definitions, see the section titled 'Definitions and Abbreviations' on page no. i of this Prospectus. In the section titled 'Main Provisions of Articles of Association of our Company' beginning on page no.189 of this Prospectus, defined terms have the meaning given to such terms in the Articles of Association of our Company.

Market data used throughout this Prospectus was obtained from internal company reports and industry publications. Industry publications generally state that the information contained in those publications has been obtained from sources believed to be reliable but their accuracy and completeness are not guaranteed and their reliability cannot be assured. Although we believe market data used in this Prospectus is reliable, it has not been independently verified. Similarly, internal company reports, while believed by us to be reliable, have not been verified by any independent sources.



## 2. FORWARD-LOOKING STATEMENTS

Statements included in this Prospectus which contain words or phrases such as “will”, “aim”, “will likely result”, “believe”, “expect”, “will continue”, “anticipate”, “estimate”, “intend”, “plan”, “contemplate”, “seek to”, “future”, “objective”, “goal”, “project”, “should”, “will pursue” and similar expression or variations of such expressions, that are “forward-looking statements”.

All forward looking statements are subject to risks, uncertainties and assumptions that could cause actual results to differ materially from those contemplated by the relevant forward looking statement. Important factors that could cause actual results to differ materially from our expectations include, among others: -

- General economic and business conditions in India and other countries
- Regulatory changes relating to our industry/sector in India and our ability to respond to them
- Price of raw materials our Company consumes and the products that our Company produces;
- Increased competition in the agrochemical and bio-diesel industry;
- Our ability to successfully implement our strategy, our growth and expansion, technological changes, our exposure to market risks that have an impact on our business activities for which funds are being raised through this Issue;
- Company’s ability to meet its capital expenditure requirements;
- Fluctuations in operating costs;
- Company’s ability to attract and retain qualified personnel;
- Changes in technology;
- The monetary and fiscal policies of India, inflation, deflation, unanticipated turbulence in interest rates, foreign exchange rates, equity prices, the performance of the financial markets in India and globally, changes in domestic and foreign laws, regulations and taxes and changes in competition in our industry;
- Changes in the value of the Rupee and other currencies;
- The occurrence of natural disasters or calamities;
- Changes in the political situation in India.

For further discussion of factors that could cause our actual results to differ, see the section titled “Risk Factors” beginning on page no.xii of this Prospectus. By their nature, certain market risk disclosures are only estimates and could be materially different from what actually occurs in the future. As a result, actual future gains or losses could materially differ from those that have been estimated. Neither our Company nor any of their respective affiliates have any obligation to update or otherwise revise any statements reflecting circumstances arising after the date hereof or to reflect the occurrence of underlying events, even if the underlying assumptions do not come to fruition. In accordance with SEBI requirements, our Company, and the Lead Manager will ensure that investors in India are informed of material developments until such time as the grant of listing and trading permission by the Stock Exchange.



### 3. RISK FACTORS

An investment in Equity Shares involves a high degree of risk. You should carefully consider all the information in this Prospectus, including the risks and uncertainties described below, before making an investment in the Equity Shares of our Company. If any of the following risks actually occur, the business, results of operations and financial condition could suffer, the trading price of the Equity Shares of our Company could decline and you may lose all or part of your investment.

Prior to making an investment decision, prospective investors should carefully consider all of the information contained in this Prospectus, including financial statements included in this Prospectus beginning on page no.107 Unless stated otherwise, the financial data in this section is as per our financial statements prepared in accordance with Indian GAAP.

Unless specified or quantified in the relevant risk factors below, we are not in a position to quantify the financial or other implications of any of the risks described in this section.

Materiality:

The Risk factors have been determined on the basis of their materiality. The following factors have been considered for determining the materiality:

- a) Some events may not be material individually, but may be found material collectively.
- b) Some events may have material impact qualitatively instead of quantitatively.
- c) Some events may not be material at present, but may be having material impacts in future.

The risk factors are as envisaged by the management along with the proposals to address the risk, if any. Wherever possible, the financial impact of the risk factors has been quantified

#### INTERNAL TO OUR COMPANY

##### **1. Allegations and litigations by Rallis India Limited against the Company and its Promoters**

Rallis India Limited ("Rallis") has alleged that one of our Promoters and Managing Director Mr.K.T.Vijaya Kumar was a former employee of Rallis and had worked as Regional Manager of Sales. Rallis has alleged that Mr.K.T.Vijaya Kumar had recommended appointment of two firms i.e., Lakshmi Agencies and Vaishnavi Agencies as Dealers of Rallis, even though the said firms did not have the credit worthiness claimed by them. Rallis has further alleged that the said firms had siphoned sale proceeds received instead of remitting such proceeds to Rallis. Further, certain cheques of the partnership firm Lakshmi Agencies were dishonoured upon presentation for payment by Rallis. Rallis filed cases u/s 138 of Negotiable Instruments Act against the partners of Lakshmi Agencies.

Rallis has further alleged that Mr.K.T.Vijaya Kumar had been a party to the incorporation of our Company and thereby the code of conduct applicable to employees of Rallis.

An FIR was lodged on 19<sup>th</sup> January 2007 at Satyanarayana Puram Police Station, Vijayawada by one Mr. Ankur Sarma, an employee of C F R Limited against Mr. K.T. Vijaya Kumar. The FIR lodged against him, alleging offences under sections 403, 405, 406, 408, 415, 420 read with Section 34 of Indian Penal Code. The FIR was later transferred by the police to the Economic Offences Wing of Crime Branch, Vijayawada Police which carried out an investigation in the matter and filed their report before the Court of Chief Metropolitan Magistrate, Vijayawada. As per the investigation report the complaint filed by the complainant has been considered as "a mistake of fact". The Court of Chief Metropolitan Magistrate, Vijayawada after considering the report has passed an order dated March 25, 2008 in terms of the report.

In the meantime, our Company had proposed a public issue of its shares in the year 2006 and filed a draft prospectus with SEBI on April 19, 2006. Rallis filed a memorandum of objections setting out the pending legal matters with respect to the Company and Mr.K.T.Vijaya Kumar had not been disclosed in the draft prospectus.

In the light of the above developments and a change in the structure of the proposed project proposed under the earlier draft prospectus.

Our Company withdrew the draft prospectus on July 14 2006, Rallis also addressed letters to several agencies, including the present Co-Lead Manager - Ashika Capital Limited, levying various allegations



against our Company and Mr.K.T.Vijaya Kumar.

Our Company filed a suit (No.12 of 2007) before the IInd Additional Senior Civil Judge, Vijayawada urging the Court to restrain Rallis from addressing letters and defaming the Company and its Promoter. The IInd Additional Senior Civil Judge, Vijayawada granted an injunction order against Rallis restraining it from making defamatory allegations against the Company and the Promoter. The interim injunction was later made absolute by an order dated 5<sup>th</sup> March 2007. No further proceedings have been filed by Rallis against the above order.

Aggreived by the conduct of Rallis, our Company also filed a criminal complaint (No:535/2007) before the 1st Additional Chief Metropolitan Magistrate Court Vijayawada against Rallis and some of its officials and Directors under sections 499 and 500 of the Indian Penal Code for criminal defamation. The court issued summons against certain officials of Rallis requisitioning their attendance in the matter. Rallis and such officials who were served the summons preferred a Criminal Petition (CRL petition No:3917 of 2007) before the Hon'ble High Court of Andhra Pradesh requesting for quashing of the summons issued and to stay the proceedings before the magistrate/trial court. The Hon'ble High Court of Andhra Pradesh passed an order granting stay on the proceedings of the trial court.

The above proceedings are currently at various stages before respective Courts and shall come up for hearing in the normal course. For further details of these litigations, please refer to the section on "Outstanding Litigations and Material Developments on 145 of this Prospectus.

**Other Litigations filed against our Company**

No.	Particulars	No. of cases / disputes	Amount involved where quantifiable (Rs. In Lakhs)
<b>Litigations against our Company</b>			
<b>A) Civil Matters</b>			
1.	Civil cases against JFI	Nil	Nil
<b>B) Indirect Tax (Sales Tax) Proceedings</b>			
2.	Sales Tax cases	1	8.40
<b>C) Direct Tax Proceedings</b>			
	AY 2005-2006	1	16.00
<b>C) Compliant filed under Section 138 of the Negotiable Instrument Act, 1881</b>			
1.	Criminal Complaint under section 138 and 142 of Negotiable Instrument Act, 1881	1	5.00

For further details of these litigations, please refer to the section on "Outstanding Litigations and Material Developments on page no.148 of this Prospectus.

**Risks related to proposed Bio Diesel Project:-**

**2. The Bio Diesel production /manufacturing is a relatively new concept to India and it is yet to have a defined market as compared to its contemporary conventional fuel .**

Bio-diesel manufacturing is a novel concept and is in a nascent stage to have a defined market as compared to other conventional manufacturing units manufacturing other products. Even though the product and technology is new to India, it has already been proven in other countries such as USA, France, Germany, Italy etc.

**3. The project is significantly dependent on adequacy and timely availability of Jatropha seeds, the extracts of which are used for the production of Bio Diesel. Non-availability or short supply of these seeds would adversely affect the business of our Company.**



Our Company is dependent on external suppliers for supply of Jatropha Seeds, main raw material for extraction /production of bio-diesel. Our company has entered into agreement with M/S Jetro Petro Biotech Private Limited, our Subsidiary company to procure and supply jatropha seeds to us. Our full requirement (100%) of the Jatropha seeds would be met from our subsidiary company only M/S Jetro Petro Biotech Limited (JPBL), has entered into a nine-year seed procurement agreement with 179 farmers holding 2,200 acres of land. The failure of the supplier to deliver the raw material in the necessary quantities or to adhere to delivery schedules or specified quality standards, could adversely affect its business and its ability to deliver on time and at the desired level of quality giving rise to contractual penalties or liability, for failure to perform contracts, and loss of customers and damage Company's reputation, any of which could materially adversely affect its results of operations. Also, the availability of this agricultural produce could be affected by various natural factors such as inadequacy of rainfall, attacks from pests, natural calamities such as droughts or floods, non-availability of water, etc.

**4. The fund requirement of Rs.2040.15 Lakhs mentioned in the Objects of the Issue has not been appraised by any bank or financial institution.**

Our company is proposing to set up a Bio diesel manufacturing plant and also to expand the agrochemical division at an aggregate cost of Rs 2040.15 lakhs constituting about 83 % of the issue size have not been appraised by any bank, financial institution or other independent agencies and are based on our management estimates. For details please refer to the "Objects of the Issue" on page no.28 of this Prospectus. In view of the competitive nature of the industry in which we operate, we may have to revise our management estimates from time to time and consequently our funding requirements may also change. This may result in the rescheduling of our project expenditure programmes and our results of operations may be adversely impacted.

In terms of Clause 8.17 of the SEBI DIP Guidelines, 2000, there is no requirement of Monitoring Agency. Our Board will monitor the utilization of the proceeds of the Fresh Issue. Pursuant to Clause 49 of the listing agreement, our Company shall on a quarterly basis disclose the uses and application of the proceeds of the Fresh Issue. We will disclose the utilization of the proceeds of the Fresh Issue under a separate head in our balance sheet till such time the proceeds of the Fresh Issue have been utilised, clearly specifying the purpose for which such proceeds have been utilized. We will also, in our balance sheet till such time the proceeds of the Fresh Issue have been utilised, provide details, if any, in relation to all such proceeds of the Fresh Issue that have not been utilized thereby also indicating investments, if any, of such unutilized proceeds of the Fresh Issue.

**5. The success of the Bio diesel plant is dependant on the Bio diesel /bio fuel purchase policy and the blending norms to be fixed by the Government from time to time .**

The Ministry of Petroleum and Natural Gas, India has notified a Bio-diesel Purchase Policy, which provides for purchase of bio-diesel by oil marketing companies at the rate of Rs 25 per litre (inclusive of taxes/duties/transportation cost) with effect from January 1, 2006, at about 20 purchase centers in 12 states. The suppliers should have the capacity to supply minimum 10KL per tanker of bio-diesel meeting prescribed BIS specifications and should be registered with the state level coordinator of oil companies. The blending of bio-diesel at a maximum of 5 percent will be undertaken initially at these 20 centers depending on its availability. Any downward revision in the purchase price of bio diesel by the Government may adversely affect the profitability of the company.

**6. Inadequate Jatropha plantation will impact ability to provide sustained supply of raw material**

The supply of biodiesel is contingent upon the Jatropha plantation programme undertaken by the Government. A considerable portion of the programme has been made part of initiatives of rural employment scheme and forest management programmes. However, the progress of these schemes is slow. The jatropha plantation after accounting for the initiatives by various states and private players is estimated to be less than 0.5 million hectares in 2007-08. Though the land for cultivation of jatropha has been identified, large scale plantation would require the involvement of farmers, self help groups and panchayati raj institutions. A large scale plantation of jatropha is imperative, as it can ensure sustained availability of biodiesel. Inadequate and sustained availability of Jatropha seeds may adversely affect the profitability of the company

**7. Shifting of cultivation of Jatropha plants from waste lands to fertile agricultural lands may adversely affect the country's food security**





The Jatropha plants are proposed to be grown in waste land areas. The farmers may resort to cultivation of Jatropha in fertile agricultural lands if it is more remunerative than the cultivation of food crops and that may seriously impact country's food security. If that happens Government may regulate the area under jatropha cultivation to maintain the food balance. This may in turn lead to scarcity of jatropha seeds leading to increase in the prices of Jatropha seeds, the raw material for our bio diesel plant and that will have negative impact on the profitability of our company.

**8. We have not placed orders for certain plant and machinery, equipments, etc. amounting to Rs.542 Lakhs as stated in the section titled 'Objects of the Issue' beginning of this Prospectus and any delay in placing such orders may delay the implementation schedule.**

Our Company intends to use the net proceeds of the Issue to, among other things, to set up bio diesel plant and the cost of plant and machinery, to be procured indigenously is Rs 542 lakhs which constitutes about 22 % of the issue proceeds. For details of plant and machinery to be purchased please refer to the "Objects of the Issue" on page no.28 We have not yet placed orders for any plant and machinery . Any increase in prices of the plant and machinery may adversely affect our estimates of project cost.. Accordingly, prospective investors in the Issue will need to rely upon the judgment of our management with respect to the use of proceeds in this respect. In the event we are unable to enter into arrangements at favourable terms and conditions, as expected and assumed by us, or in a timely manner. Any difficulties in obtaining timely support of plant and machinery may adversely impact the implementation of the projects. In the event we are unable to enter into arrangements at favorable terms and conditions, as expected and assumed by us, or in a timely manner or at all, we may not be able to reap the expected benefits from the net proceeds of the Issue and our financial results may suffer.

**9. Rise in cost of raw material may adversely affect the financial performance of our Company**

If the costs of Jatropha seeds were to rise due to factors such as rises in input and commodity prices or shortages in supply, and our Company is not able to recover these costs through cost saving measures elsewhere or by increasing the prices of bio-diesel, its results of operations could be adversely affected. As such, should cost of materials rise, our Company can provide no assurance that it will be able to pass on any additional costs to its customers, and accordingly its results of operations might suffer. The success of biofuels programme depended on the price at which they are produced. The cost of production should be lower than fossil fuel cost.

**10. Absence of entry barriers into Bio-diesel production may attract many players from both organized and unorganized sectors which will escalate competition and resultant price pressure on the products.**

There are no entry barriers for setting up Bio-diesel unit. Due to no entry barriers, many players from the organized as well as the un-organised sector may enter this industry. The entry of these players may result in competition and resultant price pressure on the products.

**11. Our Company is promoted by first generation entrepreneurs having no prior experience in Bio diesel business, which is unrelated to the present business activities of our Company; the investors will be subjected to all consequential risk associated with such ventures.**

Our Promoters and management include persons who are first generation entrepreneurs. Pursuant to the issue, our Promoters and management are required to comply with various statutory and regulatory filings and disclosures which expose them to risks which may lead to penal and other consequences.

**Risks internal to the Company:**

**12. Our Company has a pending sales tax dispute case before the Hon'ble High Court, Andhra Pradesh, involving a sum of Rs.8.40 lakhs and if the decision is not in our favour it could impact our cash flows.**

The Commercial Tax Officer, ( CTO) ,Vijayawada by an order dated March 25, 2006 has assessed the total tax payable to be Rs. 32.10 lakhs for the assessment year 2002-03 out of which the Company has already paid Rs.23.70 lakhs . Our Company has obtained a stay under an order dated September 13, 2006 in WPMP 23787/2006 in WP 16932/2003 from the Andhra Pradesh High Court against the order of



the CTO demanding the remaining amount of Rs.8.40 lakhs . No further proceedings have taken place in this matter. **This amount has been included as “Contingent Liabilities” in the audited financial statements of our company.** For further details of these litigations, please refer to the section on “Outstanding Litigations and Material Developments on page no.148 of this Prospectus.

**13. Our Company has delayed payment of statutory dues to the extent of Rs 52.00 lakhs.**

Our company has delayed payment of Rs 39.90 lakhs to the Income Tax department and Rs 12.05 lakhs to the excise department for the FY 2006-07 .If the The authorities concerned impose penalties our financials may be adversely impacted.

**14. Our Short Term Loan facility with Union Bank of India is due for payment . If the Bank recalls our loan facility before the IPO process is completed it may adversely affect our cash flows**

A short term loan of Rs 120 lakhs was sanctioned by Union Bank of India, Vijayawada branch, vide their letter dated November 08, 2006 for meeting the expenses related to the proposed Bio diesel Project as mentioned in the objects of the issue . The repayment of this loan is one of the objects of the issue For details please refer to the “Objects of the Issue” on page no. 28 of this prospectus.Our Company has been servicing the interest component but as the IPO was delayed the repayment of Principal has become overdue. We have requested Union Bank of India to extend the repayment period till October 2008 or completion of IPO process which ever is earlier . The request is under active consideration of the Bank. The present outstanding in the account is Rs 119.20 lakhs.

If the Bank does not accept our request and call up our advance before the IPO process is completed our cash flows are adversely affected.

**15. The Agro Chemical Business is seasonal in nature and the fortunes of Agro-Chemical industry are influenced and closely linked to the growth and development of the overall agricultural sector, which in turn is dependent on monsoons.**

The agrochemical business industry is subject to seasonal and weather factors, which make its operations relatively unpredictable. Fluctuations in the weather conditions across various regions can negatively affect the demand for crop protection products and the mix of products used. In the event of natural calamities such as drought, insufficient rainfall or floods, demand for our Agro chemical products may reduce and this will adversely affect our sales and profitability. However, its impact would be less on our Company's working, its business area being Krishna, Guntur, Khammam & West and East Godavari districts of Andhra Pradesh State with well developed irrigation facilities.

**16. We have high working capital requirements. If we experience insufficient cash flows to allow us to make required payments on our debt or fund working capital requirements, there may be an adverse effect on our results of operations.**

Agro chemical industry requires high working capital due to its seasonal nature and long credit period given to dealers and farmers. Thus, high inventories during off-season period and high receivables during poor monsoon put further pressure on working capital requirement.

**17. Our sales are to a large extent dependent on the overall area under cultivation and the cropping pattern adopted by the farming community in India. If cropping pattern of the area changes significantly and if we do not introduce new products to suit the new cropping pattern it may affect our results of operations**

Our sales for the FY 2007 was Rs.2333.69 lakhs of which we derived about 40% of sales from pesticides used on paddy, about 40% from pesticides used on cotton & chillies and about 20% from pesticides used on pulses. Thus our Company derives bulk of sales from major pesticides used on crops like Paddy, Cotton and Chillies etc. Any significant reduction (10% or more) in the area under cultivation in these crops may significantly reduce the demand for our products. Also the demand of our products is dependent on the cropping pattern which may vary year on year for these major crops. Any significant changes in the cultivable area and the cropping pattern in India of these crops may impact our sales and profitability

**18. Considering seasonality of our business, our sales and profits may be low during periods other than monsoon time.**



Our Company's quarterly operating results may fluctuate from quarter to quarter due to the seasonality of the Agrochemical business in India. We, therefore, believe that period-to-period comparison of results of our operations are not necessarily meaningful and may not be a reliable indication of our company's future performance

**19. Pests develop immunity to the pesticides over a period of time and as a result our products may not be effective and such situation may warrant us to introduce suitable new products which may not be as effective against the pests. This may adversely affect our business operations and our reputation.**

From empirical tests and data, it is well documented that over a period of time pests develop immunity to the pesticides which are used constantly. Hence over a period of time the pests may develop immunity for our products. We may be required to change the range of our products and/or develop new products, which may not be as effective against the pests, which may adversely affect our business operations and our reputation.

**20. Our failure to obtain and renew regulatory approvals required for our business may be detrimental for our business.**

Pesticides industry is highly regulated industry in India. For details of various approvals, Licences required by our Company please refer to section titled "**Government Approvals / Licensing Arrangements**" beginning on page no. 151 of this Prospectus. Most of our licences and approvals for manufacturing pesticides products are valid for certain period and requires regular renewals. These renewals are required in ordinary course of business and are subject to our compliances with various conditions stipulated in those approval/ Licences. In case we are unable to get our licences and approval renewed in time our production may be hampered, which can affect our results of operations and financials.

Our Company has made the following application for the bio-diesel business of the Company:

Industrial Entrepreneur Memorandum (IEM)- Ministry of Commerce and Industry	For commencing Bio Diesel Manufacturing unit	Application dated 25 <sup>th</sup> July 2005 submitted to authorities	Acknowledgment dated 09.09.05 received from Ministry of Commerce & Industry, New Delhi, regarding filing of Industrial Entrepreneur Memorandum
---	--	---	--

The under mentioned applications are yet to be made by our company :

Certificate of Explosives Factory Licence for Biodiesel Plant Power requirement for Biodiesel plant Water requirement for Biodiesel plant	For use and storage of Methanol For Biodiesel plant at Kondapalli 125 KVA power connection required Sufficient water is available at the present location and fresh connection not required	Application yet to be made Application yet to be made Application yet to be made	Time for getting sanction will be 30 days
--	--	--	---

**Our company shall apply for these approvals on or before commissioning of the bio diesel plant.**



**21. Our inability to meet the quality norms which include the composition and specifications set out by Department of Agriculture & Co-operation, Ministry of Agriculture, Government of India, standards published by Bureau of Indian Standards (BIS) and analytical procedure for quality control prescribed by Central Insecticides Board (CIB) may lead to penal action against us which will impair our business.**

The composition and specifications of every pesticide /insecticide has been specified by the Registration Committee, Government of India and/ or standards published by Bureau of Indian Standards ( BIS) . Central Insecticides Board( CIB) also prescribes analytical procedures for quality control . The issuer company has registration for manufacturing 34 pesticide formulations and each of these products has its own specifications and standards. Thus the products manufactured by our Company should conform to the standards and analytical procedures specified by the CIB and / or Bureau of Indian Standards..

Thus quality of pesticides products manufactured in India is open to independent verification by Government agencies. Government agencies carry out surprise sample checking of our product for their contents. In case, the content in the sample does not comply with the quality norms prescribed by the Government, it could lead to issuance of show cause notices. Any failure on quality control by our Company could lead to suspension of sales of those batches and /or product in that particular state or our products being banned for sales. In past our Company has not faced any suspension/ ban on sale of any product. However the same cannot be guaranteed for future. Any such event are likely to impact our business.

**22. Our ability to introduce new products is dependent on getting the approval for manufacturing and/ or selling under Insecticides Act and if we fail in our endeavour to get such approval, we may not be able to give new products to the market and this in turn may adversely affect our operations .**

As per Section 9 of the Insecticides Act, any person desiring to import or manufacture any insecticides may apply to registration committee (Central Insecticides Board and Registration Committee) for registration of such insecticides and there shall be separate registration for each insecticide. Our Company has duly obtained Certification of Registrations under the Insecticides Act, 1968, for manufacturing 34 pesticides at our plant. Currently there are no pending applications for any insecticides. Our ability to introduce new products either developed in house or imported from elsewhere is subject to getting these registrations. Over a long period of time pests develop immunity to the pesticides used. Hence inability to launch new products to overcome such immunity will affect our business.

**23 . Indiscriminate usage of pesticides manufactured by us by the end user could badly affect our brand image, sales and ultimately our profitability.**

All our products are packed with instructions about the optimum dosage and usage method. However any wrong usage of our pesticide by any farmer could damage his crop, which could raise questions on our product quality and tarnish our brand image. Any occurrence of such incidents could impact our sales and hence our profitability. Moreover, we may face litigations and claims in the event of any damage to crops because of our products.

**24.Usage of hazardous chemical substances in our production process could lead to fatal accidents and litigation by the affected parties which may impact our business operations.**

We are exposed to risk of usage of hazardous chemicals and substances in production. Any mishandling of hazardous chemical substances could lead to fatal accidents, which may affect our business operations. Chemicals may cause acute poisoning or burns, chronic health problems, or have long-term effects such as cancer, fetal damage and reduced fertility. In order to prevent such mishandling our Company has established various measures including training of workers, no entry to production area without safety devices, prominent display of safety measures and precaution measures in production area etc. No effluents will generate in the process; However fresh air induction systems have been installed to create a better production environment.

**25 If we fail to comply with environmental laws and regulations or face environmental Litigation, our results of operation may be adversely affected.**

Environmental laws and regulations in India are becoming stringent and it is possible that they will become significantly more stringent in the future. If, as a result of non-compliance with any environmental regulations,



any heavy penalty is imposed on us or any of our units or the operations of such units are shut down, we will continue to incur costs in complying with these regulations, appealing against any decision to close our facilities, maintaining production at our existing facilities and continuing to pay labour and other costs which continue, even if the facility is closed. As a result, our overall operating expenses will increase and our profits will decrease.

**26. Our future growth requires additional working capital, which may not be available on terms acceptable to us, which may impact our profitability.**

Our business is working capital intensive. We intend to pursue a strategy of funding our major working capital requirements from banks and other financial institutions. We may not be successful in obtaining these funds in a timely manner, or on favorable terms or at all. We cannot assure you that our future working capital requirements shall be funded at the current/lower cost. Our inability to get funds on acceptable term could impact our growth and profitability.

**27. Our indebtedness and the conditions and restrictions imposed by our financing agreements could restrict our ability to conduct our business and operations**

As on March 31, 2008, we have availed an aggregate of Rs.665.64 Lakhs as secured loans from our bankers. Most of our loans are secured by way of mortgage of fixed assets and hypothecation of current assets both present and future. In case we are not able to pay our dues in time, the same could adversely impact our operations. In addition to the above our financing arrangements also include conditions and covenants that require us to obtain consents of our lenders prior to carrying out certain activities and entering into certain transactions like effect any change in the capital structure, undertake any new project/expansion/modernization scheme or make any capital expenditure other than those estimated or projected, enter into borrowing arrangement either on secured or unsecured basis with any other bank/ FI/ borrower or otherwise etc. For details of restrictive covenants of our loan, please refer to sub section titled "Restrictive covenants of the loans agreements" on page no 82 of this Prospectus. Failure to obtain such consents in time can have significant consequences on our capacity to expand and therefore adversely affect our business and operations.

**28 Increased competition may result in decreased demand or lower prices for our products. Our failure to effectively compete could reduce our profitability.**

We face substantial competition due to technological advances by competitors, such as other pesticide companies, agro-chemical and biotechnology companies. We compete with other pesticide manufacturers on the basis of availability of product, product range, product traits, including disease resistance, plant quality and other factors, as well as based on price, reputation, customer service and customer convenience. Further, the introduction of biotechnology has resulted in the entry of various agrochemical companies into the pesticide industry, thus increasing the competitive landscape in the industry.

The number of products available to the grower is steadily increasing as new products are being introduced. As a result, we anticipate that we will continue to face new and different competitive challenges in attracting the farmers. If a competitor introduces a successful product, it could take years for us to develop a product, which could have a material adverse effect on our business, results of operations and financial condition.

Some of our competitors are large Indian companies or subsidiaries of multi-national companies that have, significantly greater resources than those available to us. If we are unable to compete effectively, including in terms of pricing or providing quality products, our market share may decline, which could have a material adverse effect on our financial condition and results of operations.

**29. Our success depends largely on our ability to attract and retain key personnel and failure to do so could adversely affect our business.**

The success of our business will also depend on our ability to identify, attract, hire, train, retain and motivate skilled personnel. Competition for qualified agribusiness professional personnel is intense given the limited supply of such personnel, and our professionals are highly sought after by our competitors. If we fail to hire and retain sufficient numbers of qualified personnel for functions such as research and development, production, marketing and sales, operations, our business, operating results, financial condition and prospects could be materially and adversely affected.



**30. The insurance policies for an aggregate amount of Rs.515 Lakhs obtained by us may not be adequate to protect us against all potential losses, which we may be subject to in future. If we suffer a large uninsured loss or if any insured loss suffered by us significantly exceeds our insurance coverage, our business may be materially and adversely affected.**

Our operations are subject to hazards and risks inherent in the use of chemicals and other hazardous materials in the course of our production processes, such as explosions, fires, chemical spills, storage tank leaks, discharges or releases of hazardous substances and other environmental risks, mechanical failure of equipment at our facilities and natural disasters. In addition, many of these operating and other risks may cause personal injury and loss of life, damage to or destruction of our properties and the properties of others and environmental pollution and may result in suspension of operations and the imposition of civil or criminal penalties. We have an insurance cover for an aggregate sum insured for Rs 515 lakhs including an insurance cover for stocks of value of Rs 385 lakhs. For further details of insurance cover please refer to the page no. 82 of this prospectus. While we believe that we maintain insurance coverage in amounts consistent with industry norms in each of our regions, our insurance policies do not cover all risks and are subject to exclusions and deductibles. There can be no assurance that our insurance policies will be adequate to cover the losses that may be incurred as a result of such interruption or the costs of repairing or replacing the damaged equipment, facilities or crops. If we suffer a large uninsured loss or if any insured loss suffered by us significantly exceeds our insurance coverage, our business, financial condition and results of operations may be materially and adversely affected.

**31. Product defects could materially and adversely affect our business.**

The pesticides we produce may contain defective or undesired characteristics that are difficult to detect prior to their sale and use. Any defects that may be found in our products in the future could result in losses to farmers. Losses claimed by farmers may include the value of lost crops, which could greatly exceed the value of the products we sell. If we sell products which are found to be defective, large numbers of farmers may experience crop failures during the same growing season. Further, growers may attribute poor crop yields or crop failure to perceived products defects that may not exist, which could still result in claims against us. Further, while we are subject to government regulations and periodic government inspections and we believe our facilities comply in all material respects with all applicable laws and regulations, we cannot be sure that consumption of our products will not cause health-related illnesses in the future or that we will not be subject to claims or lawsuits relating to our products. Any claims, whether valid or not, could result in negative publicity and cause us to incur significant costs, which could have a material adverse effect on our business, results of operations and financial condition.

**32. Our customers may be unable to pay their debts to us due to local economic conditions which could adversely affect the results of our operations and financial condition.**

Normally, we deliver a significant portion of our products against future payment. Our credit terms vary according to local market practice. Our customers are exposed to downturns in the local economy that may impact their ability to pay their debts, which could materially and adversely affect our results of operations. Our Company has not experienced material losses in this respect, but in severe abnormal conditions there can be a significant impact on our customers' ability to pay their debts, which could result in a material adverse effect on our business, results of operations and financial condition.

**33. We may not be able to sustain effective implementation of our business and growth strategy on time and within the estimated budget and this could have adverse effect on our business, financial condition and the results of operations.**

The success of our business will depend largely on our ability to effectively implement our business and growth strategy. Whilst we have generally been successful in execution of our business strategy in the past, there can be no assurance that we will be able to execute our strategy on time and within the estimated budget in future. If, we are unable to implement our business and growth strategy on time and within the estimated budget, this may have an adverse effect on our business, financial condition and results of operations.

**34. We may not be able to develop new products at a pace that our competitors may successfully achieve and the same could result in the loss of customers which could obviously affect our business and profitability.**



Our success depends, in part, on our ability to develop new products to meet the changing needs of our customers. We have in the past made, and intend to continue to make, significant investments in development of new products seeds to meet consumer demands and keep pace with new product introductions by our competitors. The development process for new pesticides is lengthy and costly. Despite substantial investments in this area, we may not be able to develop new products. The success of our new product offerings will depend on several factors, including our ability to:

- accurately anticipate and properly identify our customers' needs and industry trends
- innovate, develop and commercialize new products and applications in a timely manner;
- differentiate our products from our competitors' products;
- launch new varieties/products on a timely basis; and
- price our products competitively.

The continuous introduction of new products designed to meet the needs of our customers is critical to our business. However, there can be no assurance that a new product will be commercially successful. In addition, research undertaken by competitors may lead to the launch of competing or improved products that may materially and adversely affect the sales of our products. Our business and financial condition could be materially and adversely affected if we are unable to successfully develop and commercialize new products.

**35. We may not be able to obtain intellectual property rights, or maintain such rights obtained from third parties and this could** have a material adverse effect on our business, results of operations and financial condition

Our ability to develop and market new products may depend on whether we are able to obtain and maintain the right to use applicable proprietary technologies and other intellectual properties owned by third parties. Obtaining the rights to use these technologies and other intellectual properties can be complicated because:

- Technologies may be subject to proprietary intellectual property rights, many of which have been patented;
- Licenses for proprietary technologies and other intellectual properties may not be available on terms acceptable to us or because exclusive rights to use them are given to other companies.
- Any failure to obtain and maintain third party rights to use technologies that are important to our business could have a material adverse effect on our business, results of operations and financial condition.

**36. We may be subject to claims of infringement of third-party intellectual property rights resulting in unexpected expenses. In addition, if we are required to cease production of affected items, our revenue could be materially and adversely affected.**

While we endeavour to ensure compliance with the intellectual property rights of third parties, we cannot determine with certainty whether we are infringing upon any existing third party intellectual property rights. We have been producing the 34 insecticides for over 10 years, but we cannot assure you that the registered owners of such trademarks/products will not seek to dispute our use in the future. Any claims of infringement, regardless of merit or resolution of such claims, could force us to incur significant costs in responding to, defending and resolving such claims, and may divert the efforts and attention of our management and technical personnel away from our business. As a result of such infringement claims, we could be required to pay third party infringement claims, alter our technologies, obtain licenses or cease some portions of our operations. The occurrence of any of the foregoing could result in unexpected expenses. In addition, if we are required to cease production of affected items, our revenue could be materially and adversely affected.

**37. We rely on the success of our distribution network and dealership. Any lapse on our part to maintain and strengthen this network may adversely affect our results of operations and financial condition.**

We rely on our distribution network and dealerships to distribute, market and sell our products. Competition



for the pesticide dealers is intense. Hence, our business is dependent on maintaining good relationships with our distributors and dealers and ensuring that our distributors and dealers are successful. Furthermore, our growth as a business depends on our ability to attract additional high-quality dealerships to our distribution network. While we believe that we have good relations with our distributors and dealers, there is no assurance that our current distributors and dealers will continue to do business with us or that we can continue to attract additional distributors and dealers to our network. If we do not succeed in maintaining the stability of our distribution network and attracting additional high-quality dealers to our distribution network, our market share may decline, materially and adversely affecting our results of operations and financial condition.

**38. Any Future Equity Offerings may lead to dilution of equity and may affect the market price of equity shares of our company.**

Our Company may require further infusion of funds to satisfy its capital needs and future growth plans, which our Company may not be able to procure. Any future equity offerings by our Company may lead to dilution of equity and may affect the market price of the Equity shares.

**39. Our Company had filed Draft Prospectus with SEBI on 19.04.2006 for its IPO and subsequently withdrawn on 14.07.2006.**

As per the Audited Financial Statements, the Company has certain contingent liabilities, which, if determined against it in future, may impact its financial position, adversely. Details of the contingent liabilities as on March 31, 2007 and March 31, 2008 are given in the following table:

(Rs. in lakhs)

	PARTICULARS	As At	
		Mar 31, 2007	Mar 31, 2008
	Claims against our Company not acknowledged as debts:		
i.	Sales Tax Appeal pending with Hon'ble High Court, Hyderabad	8.38	8.38
ii.	Guarantee given to Banks	62.00	62.00

If any of these contingent liabilities were to materialize, it may have a material and adverse impact on our financial condition.

**40. Our Company had filed Draft Prospectus with SEBI on 19.04.2006 for IPO and subsequently withdrawn on 14.07.2006.**

Our company had filed Draft Prospectus with SEBI on 19.04.2006. Before filing the draft prospectus with SEBI, Rallis India had filed a case against Mr K.T. Vijaya Kumar, Managing Director of the company. As the case was subsequently withdrawn at the time of Draft prospectus the same was not disclosed in the offer document. Further, the Bio diesel project was prepared in the year 2005 ie about a year before the filing of Draft Prospectus. The project cost was revised due to time lag between the project preparation and the filing of offer document. To enable us to disclose the dispute between Rallis India Limited and the Managing Director of our Company and also to revise the project cost the offer document was withdrawn on 14.07.2006.

**41. We have had negative cash flows in the recent five years period, as indicated in the table below**

(Amount in Rs lakhs)

	For the Year Ended 31 <sup>st</sup> March				
	31.03.08	31.03.07	31.03.06	31.03.05	31.03.04
Net cash from (used in) operating activities	147.88	(648.37)	(567.74)	(135.33)	56.82
Net cash from (used in) investing activities	31.37	564.85	(579.03)	(14.63)	(49.64)
Net cash from (used in) financing activities	57.54	84.33	1145.45	148.24	(3.91)





**42. We have entered into certain related party transactions and may continue to do so in the future. These transactions are carried at the arms length basis but there can be no assurance that these transactions were/will be achieved in the most favourable terms. Further there could be no assurance that in future such transactions will not have any adverse effect on our financial condition and results of operation. .**

Our Company has in the past entered into and expects to continue to enter into related party transactions with our Promoters, Directors and/or subsidiary Company. The aggregate value of the related party transactions for FY 08, FY 07 and FY 06 are Rs 572.64 lakhs, Rs 37.69 lakhs and Rs 25.00 lakhs respectively. The related party transactions include remuneration and dividend to the Directors, expenses of relatives of Key Managerial personnel and advance given to subsidiary company. While we believe that all such transactions have been conducted on the arms length basis, there can be no assurance that we could not have achieved more favourable terms had such transactions not been entered into with related parties. There can be no assurance that such transactions, individually or in the aggregate, will not have an adverse effect on our financial condition and results of operation. For details, please refer to section titled "Related Party Transactions" on page no. 105 of this Prospectus.

43. The company and Directors are Making an application under Section 621A of the Companies Act 1956, with Company Law Board, Southern Region Bench Chennai for compounding certain offences such as Non disclosure of Previous Year Figures in the Schedules to the Balance Sheet and the Mismatch of Figures appearing in the Balance Sheet for the year ending 31-03-2004, 31-03-2005, 31-03-2006, Non Disclosure of composition of Audit Committee in Directors Report for the year 2006, 2007 and 2008.

We found some mistakes and mis matches those are happened unintentionally and inadvertence, in order to rectify and making good, the application will be filed with Company Law Board, Southern Region Bench Chennai.

## **B. EXTERNAL AND BEYOND THE CONTROL OF OUR COMPANY**

### **External Risk factors**

**44. Certain factors beyond the control of our Company like floods, droughts, monsoons, etc. can adversely affect operations of our Company.**

Natural calamities like floods and droughts directly affect the cropping pattern in India, where agriculture is dependent on monsoon. To that extent our sales are dependent on the monsoon. Our sales and profitability may be affected due to excessive rains or droughts, when the farmers do not undertake cropping.

**45. Any significant change in the Government's economic liberalization and deregulation policies could disrupt the business and adversely affect the financial performance of our Company.**

Any significant change in the Government's policies or any political instability in India could adversely affect the business and economic conditions in India and could also adversely affect the business, future financial performance and the price of our Company's Equity Shares.

**46. The price of our Equity Shares may be volatile after listing as a result of several factors.**

The Equity Shares of our Company are currently not listed. The price of our Equity Shares on the Indian Stock Exchanges may fluctuate after listing as a result of several factors including –

- Volatility in Indian and global securities market;
  - Our results of operations and performance;
  - Performance of our competitors and perception in the Indian market about investment in the Pesticides Industry or the biodiesel industry;
  - Adverse media reports, if any, on our Company, the Pesticide Industry or the biodiesel industry;
  - Changes in the estimates of our performance or recommendations by financial analysts;
  - Significant development in India's economic liberalization and de-regulation policies; and
  - Significant development in India's fiscal and environmental regulations.
- There can also be no assurance that the price at which our equity shares are initially traded will correspond to the prices at which our Equity Shares will trade in the market subsequent to this Issue.



**47. The Issue price of our Equity Shares may not be indicative of the market price of our Equity Shares after the Issue. The market price of our Equity Shares could be subject to significant fluctuations after the Issue, and may decline below the Issue Price.**

The Issue Price of our Equity Shares is based on numerous factors (discussed in the section titled 'Basis for Issue Price' beginning from page no.40 of this Draft Prospectus) and may not be indicative of the market price for our Equity Shares after the Issue. The market price of our Equity Shares could be subject to significant fluctuations after the Issue, and may decline below the Issue Price. Among the factors that could affect our share price are:

- Quarterly and other variations in the rate of growth of our financial indicators, such as earnings per share, net income and revenues;
- Changes in revenue or earnings estimates or publication of research reports by analysts;
- Speculation in the press or investment community;
- General market conditions; and
- Domestic and international economic, legal and regulatory factors unrelated to our performance

**48. Changes in interest rates could significantly affect our results of operations.**

Changes in interest rates could significantly affect our financial condition and results of operations. Most of our borrowings are at floating rates of interest. If the interest rate for our existing or future borrowings increases significantly, our cost of servicing such debt will increase. This may adversely impact our results of operations, planned capital expenditures and cash flows.

**49. Slowdown of the Indian Economy could affect the business operations of the Company.**

Our performance and growth are dependant on the health of the Indian economy. The economy could be adversely affected by various factors such as political or regulatory action, including adverse changes in liberalisation policies, social disturbances, terrorist attacks and other acts of violence or war, natural calamities, interest rates, commodity and energy prices and various other factors. Any slowdown in the Indian economy may adversely impact our business and financial performance and the price of our equity shares.

**50. We are subject to adverse impact of economic and political conditions.**

Global economic and political factors that are beyond our control, influence forecasts and directly affect performance. These factors include interest rates, rates of economic growth, fiscal and monetary policies of governments, inflation, deflation, consumer credit availability, consumer debt levels, tax rates and policy, unemployment trends, terrorist threats and activities, worldwide military and domestic disturbances and conflicts, and other matters that influence consumer confidence, spending and tourism. Increasing volatility in financial markets may cause these factors to change with a greater degree of frequency and magnitude. The taxation system within the country still remains complex. Changes in local taxes and levies can impact our performance adversely.

**51. An active market for the Equity Shares may not develop which may cause the price of the Equity Shares to fall and may limit your ability to sell the Equity Shares.**

The stock market in general have from time to time experienced considerable price fluctuations. Often, these changes may have been unrelated to the operating performance of the affected companies. In addition, factors such as foreign exchange rates and weak overseas markets may have an adverse effect on the market price of our Equity Shares. The Equity Shares are new issues of securities for which there is currently no trading market. No assurance can be given that an active trading market for the Equity Shares will develop or as to the liquidity or sustainability of any such market, the ability of holders of the Equity Shares to sell their Equity Shares or the price at which shareholders will be able to sell their Equity Shares. If an active market for the Equity Shares fails to develop or be sustained, the trading price of the Equity Shares could fall. If an active trading market were to develop, the Equity Shares could trade at prices that may be lower than their initial offering price.

**52. Future issues or sales of our Equity Shares may significantly affect the trading price of the Equity Shares.**

Future issue of Equity Shares /convertible instruments by us or the disposal of Equity Shares by any of the major shareholders or the perception that such issues or sales may occur may significantly affect trading



price of the Equity Shares. Other than the lock-in of pre-issue capital as prescribed under SEBI DIP Guidelines, none of our shareholders are subject to any lock-up arrangements restricting their ability to issue Equity Shares or the Shareholders' ability to dispose of their Equity Shares, and there can be no assurance that any shareholder will not dispose of, encumber, or pledge, its shares. For details of lock in of pre-Issue Equity Share capital and Promoters' contribution please see the section titled "Capital Structure" beginning on page no.19 of this Prospectus.

**53. If our Company fails to comply with environmental laws and regulations or face environmental litigation, its profitability may be adversely affected**

Our Company may incur substantial costs to comply with requirements of environmental laws and regulations. In addition, our Company may discover currently unknown environmental problems or conditions. Our Company is subject to significant national and state environmental laws and regulations, which govern the discharge, emission, storage, handling and disposal of a variety of substances that may be used in or result from its operations. Environmental laws and regulations in India are becoming increasingly stringent and it is possible that they will become significantly stringent in the future. In addition, failure to comply with environmental laws may result in assessment of penalties and fines against our Company by regulatory authorities. The commencement of environmental actions against our Company or the imposition of any penalties or fines on it as a result thereof could have a material adverse effect on its business prospects and results of operations.

**54. If financial instability occurs in certain countries, particularly emerging market countries in Asia and other countries, our business and the price of our Equity Shares may be adversely affected.**

Indian markets and the Indian economy are influenced by economic and market conditions in other countries, particularly emerging market countries in Asia and certain other countries. Although economic conditions are different in each country, investors' reactions to developments in one country can have adverse effects on the securities of companies in other countries, including India. A loss of investor confidence in the financial systems of other emerging markets may cause exchange rate instability and increased volatility in Indian financial markets, and, indirectly, in the Indian economy in general. Any worldwide financial instability could also have a negative impact on the Indian economy. Financial disruptions may occur again and may harm our business, our future financial performance and the price of our Equity Shares.

**Notes to the Risk Factors:**

1. Issue of 1,54,00,000 equity shares of Rs. 10/- each at a price of Rs.16/- per equity share (including a premium of Rs.6/- per equity share) of the Company for cash aggregating to Rs. 2464 Lakhs ("Issue"). The Issue comprises a contribution by Promoters, of 16,00,000 equity shares of Rs. 10/- each at a price of Rs. 16/- per equity share for cash aggregating to Rs. 256 Lakhs ("Promoter's Contribution Portion"), 10,00,000 equity shares of Rs. 10 each reserved for Eligible Employees on competitive basis at a price of Rs. 16/- ( hereinafter referred to as Employee Reservation Portion and the Net Issue to the Public of 128,00,000 equity shares of Rs. 10/- each at a price of Rs. 16/- per equity share for cash aggregating to Rs.2048 Lakhs ("Net Issue to Public") The Net Issue to the Public would constitute 49.39% of the fully diluted post issue paid up capital of our Company.
2. The Issue price is 1.6 times of the face value of the equity share. Pre-Issue Net Worth of our Company as on March 31 ,2007 and as on March 31,,2008 is Rs. 1205.47 lakhs and Rs. 1329.27 lakhs, respectively.
3. The average cost of acquisition of Equity Shares of the Promoter is as under:

Name of the Promoter	Average Cost of acquisition of existing equity shares as on the date
Mr. Kanuparthi Balakrishna Rao	Rs. 9.82
Mr. Kanuparthi Trinatha Vijaya Kumar	Rs. 9.82
Mr. Kanuparthi Chandra Shekhar Prasad	Rs. 9.92

4. Book Value per equity share of our Company as on March 31, 2008 is Rs. 12.64 as per the restated financial statements included in the Prospectus.
5. Other than as stated in the 'Capital Structure', we have not issued any equity shares for consideration other than cash.



6. Investors are advised to refer to the paragraph on “Basis for Issue Price” on **page no. 40** before making an investment in this Issue.
7. Investors may please note that in the event of over-subscription, allotment shall be made on a proportionate basis in consultation with the Bombay Stock Exchange Limited (BSE).
8. Details of Related party transactions as at 31<sup>st</sup> March 2008 aggregating to Rs.572.64 Lakhs are given as notes to account in Auditors Report on **page no. 119** of this Prospectus.
9. Details of remuneration paid to directors are given in Managerial Remuneration on **page no.119**.
10. Except as disclosed in ‘Our Promoters’ and ‘Our Management’ none of the Promoters/ Directors/ Key Management Personnel of our Company have any interest in our Company except to the extent of remuneration and reimbursement of expenses and to the extent of Equity shares held by them.
11. No loans and advances have been made by the Company to any person(s)/ companies in whom the Directors are interested.
12. The investors are advised to refer the paragraph on Promoter’s background and past financial performance of our Company before making an investment in the proposed issue.
13. There is no relationship with the statutory auditors to our Company other than auditing and certification of financial statements.
14. Investors may note that allotment and trading in shares of our Company shall be done only in dematerialized form.
15. Investors may contact the Lead Manager or the Compliance Officer for any complaint/ clarification/ information pertaining to the Issue, who will be obliged to attend to the same.
16. Over subscription to the extent of 10% of the Issue can be retained for the purpose of rounding off to the nearest integer.
17. All information shall be made available by our Company and the Lead Manager to the public and investors at large and no selective or additional information would be available for a section of the investors in any manner whatsoever.
18. Applicants should note that on the basis of name of the Applicant, Depository Participant’s name, Depository Participant-Identification number and Beneficiary Account Number provided by them in the Application Form, the Registrar to the Issue will obtain from the Depository, demographic details of the Applicants such as address, bank account details for printing on refund orders and occupation. Hence, applicants should carefully fill in their Depository Account details in the Application Form and also update their demographic details with their respective depository participant.



## SECTION III: INTRODUCTION

### 1. SUMMARY

*This is only a summary and does not contain all information that you should consider before investing in our Equity Shares. You should read the entire Prospectus, including the information on “Risk Factors” beginning on page no.xii and our financial information of our Company and related notes beginning from page no.107 in this Prospectus before deciding to invest in our Equity Shares.*

**Note: Unless otherwise indicated, all financial and statistical data relating to the industry has been derived from internal Company reports & data, industry publication and estimates. This data has been reclassified in certain respects for purposes of presentation. For more information, see “Forward Looking Statements “ on page no. xi in this Prospectus.**

#### Industry Overview

##### Bio-Diesel Industry

The world is experiencing an energy crisis. The search for alternative fuels has been on for long. India ranks sixth in the world in terms of energy demand accounting for 3.5% of world commercial energy demand in 2001. The energy demand is expected to grow at 4.8%.

Bio Diesel is a substitute for, or an additive to, diesel fuel that is derived from the oils and fats of plants, like jatropha, pongamia, sunflower, or canola. It is an alternative fuel that can be used in diesel engines and provides power similar to conventional diesel fuel. Bio Diesel is a renewable domestically produced liquid fuel that can help reduce the countries dependence on foreign oil imports. Recent environmental and economic concerns (Kyoto Protocol) have prompted resurgence in the use of biodiesel throughout the world. Today, 21 countries worldwide produce Biodiesel.

##### Biodiesel Scenario in India

Oil provides energy for 95% of transportation and the demand of transport fuel continues to rise. The requirement of Motor Spirit is expected to grow from little over 7 MMT in 2001 –02 to over 10 MMT in 2006-07 and 12.848 MMT in 2011-12 and that of diesel (HSD) from 39.815 MMT in 2001-02 to 52.324 MMT in 2006-07 and just over 66 MMT in 2011-12. The domestic supply of crude will satisfy only about 22% of the demand and the rest will have to be met from imported crude. Our dependence on import of oil will continue to increase in the foreseeable future. It has been estimated that the demand for crude oil would go up to 85 MMTPA from about 50 MMTPA in 2001-02 while the domestic production will be around 22% of the demand. The crude prices and availability are subject to great volatility depending upon the international situation and, therefore, attempt needs to be made to reduce dependence on imports.

In biofuels the country has a ray of hope. Biofuels are renewable liquid fuels coming from biological raw material and have been proved to be good substitutes for oil in the transportation sector. As such biofuels – ethanol and biodiesel- are gaining worldwide acceptance as a solution to environmental problems, energy security, reducing imports, rural employment and improving agricultural economy.

Biodiesel is made from virgin or used vegetable oils (both edible & non-edible) and animal fats through trans-esterification and is a diesel substitute and requires very little or no engine modifications up to 20% blend and minor modification for higher percentage blends. The use of biodiesel results in substantial reduction of un-burnt hydrocarbons, carbon monoxide and particulate matters. It has almost no sulphur, no aromatics and has about 10 % built in oxygen, which helps it to burn fully. Its higher cetane number improves the combustion.

The rationale of taking up a major programme for the production of bio- fuels for blending with gasoline and diesel in our country emanates from a variety of factors. First,there is no alternative to the petroleum based fuels i.e., motor spirit or gasoline and High Speed Diesel (HSD) for the transport sector which is the major consumer of petroleum products. Secondly, biofuels are environmentally superior fuels and their use becomes compelling if the prescribed emission norms are to be achieved. Thirdly, there is need to meet the global environmental concern about climate change, ensure energy security, reduce imports, generate employment for the poor and achieve a number of other objectives of the Tenth Plan.

Ever increasing consumption of fossil fuel and petroleum products has been a matter of concern for the country for huge out-go of foreign exchange on the one hand and increasing emission causing environmental hazards on the other. Public at large are raising their concerns over the declining state of environment and health.



While the decision to blend 5% ethanol with petrol effective in eight major cities from 1.1.2003 is a step in the right direction, the ratio should gradually be increased to 10 and 20% over a period of time and extended to cover remaining parts of the country. Similarly, oil extracted from seeds of plants like *Jatropha curcas* and processed into biodiesel could be blended with petroleum diesel. *Jatropha curcas* is a quick maturing plant species that starts bearing fruits within a year of its planting and following the extraction and transesterification the oil can be blended with petroleum diesel for use. It is a very hardy plant and grows in a wide variety of agro-climatic conditions from arid (200 mm of rainfall) to high rainfall areas and on lands with thin soil cover to good lands. It is also not browsed by cattle and so its plantation can be easily undertaken in the farmers' fields and their boundaries, understocked forests, public lands and denuded lands facing increasing degradation. Its plantation, seed collection, oil extraction etc. will create employment opportunities for a large number of people, particularly the tribals and the poor, and will help rehabilitate unproductive and wastelands and save precious foreign exchange by substituting imported crude.

A modest beginning is proposed to be made by launching a National Mission on Bio-Diesel comprising six micro missions covering all aspects of plantation, procurement of seed, oil extraction, transesterification, blending and trade, and research and development. The financial requirement of the Demonstration Project is estimated at little over Rs.1496.00 crore during the Tenth Plan. The proposed plantation in 4 lakh ha. in phases will generate 127.6 million person days of work in the Tenth Plan. In addition, the seed collection will provide sustainable employment to the tune of 8 million person days or 1.22 lakh person years and primary processing, oil esterification, transport etc. will create additional jobs. There will be manifold increase in employment generation once the Demonstration Project under the National Mission has been successfully implemented and gives rise to the Second Phase in the Eleventh Plan. Thus Bio-diesel development by itself could become a major poverty alleviation programme for the rural poor apart from providing energy security to the country in general and to the rural areas in particular and upgrading the rural non- farm sector.

(Source; Report of the committee on development of bio fuel- Planning commission , Govt of India )

#### **b) Agrochemical Industry**

Pesticides, also known as agrochemicals, are essentially chemical compounds used for crop protection and public health. With growing cropping intensity, the current production capacity of the Indian pesticide industry is about 124,000 tonnes. However, this demand is seasonal, the maximum being consumed in the months from July to November. Therefore there falls a wide gap in between, as a result of which most manufacturers cannot optimize their production and the average utilization is about 65%. Nearly 67% of pesticides manufactured in India are used for two crops- Rice and Cotton. Almost 67% of the total pesticide consumed, falls in Andhra Pradesh and Punjab, which also manufacture nearly 47% of the net production.

Pesticides can be broadly classified into six categories:

1. Insecticides: used against insects
2. Fungicides: used for preventing fungus
3. Herbicides: used for removing weeds
4. Rodenticides: used against rodents
5. Nematicides: used for killing pests in the plant root
6. Regulants: used for nourishing plants

Pesticides can be manufactured and sold mainly in two forms- Technical and Formulations. Technicals is the first stage of manufacture where the chemical is concentrated and unsuitable for direct use. This is then processed with other materials to create formulations. The conversion from technical grade to formulations adds substantial value to the product. India loses Rs 100 bn annually due to crop losses. Pest control is thus an urgent necessity. The current demand for technical grade pesticides stands at about 85,000 tonnes per annum and has been growing at 5-10% annually.

Processed foods and agricultural product exports are being given a thrust in India. For this purpose quality and quantity have to be taken care of. In order to increase production and improve the quality of agricultural products, the country's dependence on better quality seeds and irrigation will have to increase. This in turn rises the demand for pesticides. It is estimated that India approximately loses 18% of the crop yield valued at Rs.900 bn due to pest attack each year. The use of pesticides help to reduce the crop losses, provide economic benefits to farmers, reduce soil erosion & help in ensuring food safety and security for the nation. The Indian pesticide



industry with 82000 MT of production for 2005-06 is ranked second in Asia (behind China) and twelfth globally. In value terms, the size of the Indian pesticide industry was estimated at Rs 68 bn for 2006, including exports of Rs. 28 bn.

Globally, due to consolidation in the industry, the top 5 global MNCs control almost 60% of the market. In India, the industry is very fragmented with about 30-40 large manufacturers and about 400 formulators. Per hectare consumption of pesticide is low in India at 381 grams when compared to world average of 500 grams. Low consumption can be attributed to fragmented land holdings, low level of irrigation, dependence on monsoons, low awareness among farmers about the benefits of usage of pesticides, etc. India, being a tropical country, the consumption pattern is also more skewed towards insecticides which accounted for 67% of the total pesticide consumption in FY06. India due to its inherent strength of low cost manufacturing and qualified low cost manpower is a net exporter of pesticides to countries such as USA and some European & African countries. Exports formed 41% of total industry turnover in FY06 and have grown at a CAGR of 18% from 00-01 to 05-06. Prior to 2005, i.e. in the process patent regime, Indian companies focused on applied research and concentrated on marketing generic and off-patent products. Due to this R&D expense by Indian companies was lower at approximately 1% of turnover. Global companies focused on high-end speciality products and dominated the market for patented new molecules. However, with onset of product patent regime in India since 2005, Indian companies will need to increase R&D expense to meet competition from MNCs. Alternatively Indian companies can be competitive in the area of CRAMs..

**(Source; ICRA research report Feb,2008)**

### **Our Business Overview**

Our Company was incorporated on September 29, 1995 with the main objective of manufacturing of Agrochemicals.

Our Company's main products are in three forms viz., liquids, granules and dusts. Our Company has CIB registrations for 34 products to manufacture pesticides for crops i.e. paddy, cotton, sugarcane, turmeric, chillies, pulses, vegetable etc., of which it is currently manufacturing 17 products.

Our Company has been predominantly concentrating in coastal districts of Andhra Pradesh, where paddy is grown extensively for its agrochemical business.

### **Key Strengths**

#### **Agrochemical Activity**

#### **Our Team and Management:**

Our Chairman Mr. Kanuparthi Balakrishna Rao, has more than 40 years of experience in this industry and has been instrumental in guiding the board in formulation of strategy and planning. Our managing director Mr. K.T Vijaya Kumar has more than 30 years experience in this industry has overall control over day to day activities of our Company and has been able to motivate our key managerial personnel to create a team of dedicated techno commercial marketing staff, dealers and distributors.

#### **Distribution Strengths:**

Our distribution network consists of distributors and dealers in 5 districts of Andhra Pradesh. We have more than 18 distributors who help us in selling our products to end users through the chain of more than 350 direct dealers and 550 retailers. We hold regular farmers meets at different places to educate and disseminate new methods of the plant protection with the help of our techno commercial marketing sales staff, dealers and distributors. With the help our distribution network & marketing team, we keep ourselves updated about the occurrence of a particular pest. Based on this information and our experience, we reschedule our production and distribution. We have established a dealer network spread through out 5 districts of A.P. wherein we maintain adequate stocks to make our products available at short notices. This strategy helps us in selling our products effectively.

#### **Major Weaknesses ;**

The fortunes of Agro chemical Industry are influenced and closely linked to the growth and development of overall agricultural sector, which in turn is dependent on monsoons.



- ii. Industry has so many entry barriers including the need for wide distribution network, strong brand image and superior product. The increased awareness of environment protection makes prior registration mandatory for large number of products.
- iii. Agro chemical industry requires high working capital due to its seasonal nature and long credit period given to farmers. Thus, high inventories during off-season period and high receivables during poor monsoon put further pressure on working capital requirement.
- iv. Heavy dependence on cash crops and in particular regions will increase the risk, particularly when those crops fail.

#### **Our Product Range:**

We have 34 products in our product portfolio which consists of different kind of pesticides. We manufacture various formulations comprising of liquids, granules and powder formulations. Our products are available in various sizes of packaging catering to the needs of small, marginal and large farmers. Our product range covers most of the crops and majority of plant infections. We provide end to end plant protection solutions to farmers through our distributors. Our product range helps us in attracting large distributors of agrochemicals to become our distributor.

#### **Our Products:**

We have registered 34 formulations with CIB. Our largest selling products are CHEMCEL HEXA; COSY; COUNTER; CELPHATE. We carry out brand awareness exercises with the help of advertisement. Our product quality and product awareness helps us in getting repeat purchases by end users.

#### **Our Production Facilities**

Our Company has set up production unit at Kanuru, Vijayawada, Andhra Pradesh for production of a wide range of pesticides which is very close to rice belts of Krishna & Godavari districts, and commercial belts of Guntur and Khammam. Land is very fertile and farmers have been taking 2 crops around the year in the area. We have a semi-automated granule sections, semi-automatic liquid lines, chemical resistant reactors for insecticides. We have laid out a quality assurance plan for all products and practices quality control checks, testing and inspection at all stages. In recognition of the quality system, established by our Company in respect of manufacturing, formulation and marketing of agrochemicals, is a set of rules that companies follow to assure that they have the systems needed to meet their customers' needs.

#### **Preserving Environment**

Our Company has established various measures for preservation of an eco-friendly production environment. Fresh air induction systems have been installed to create a better production environment.

#### **Packaging**

We have synchronized our production planning with the end user demand. We sell our product in different SKUs (Stockkeeping units) from pouches to bottles to drums. Thus we cater to the needs of all our customers from small, marginal to big farmers.

#### **Our Strategy:**

Considering the opportunities in the field of production and supply of alternative fuels to petroleum based fuels, our Company has entered into agreement dated May 25, 2007 with M/s. Jetro Petro Biotech Private Limited for procurement of raw material including Jatropha seeds, Pongamia, Neem, Palm oil seeds, cotton seeds and all such other kinds of seeds useful for the purpose.

Our Company is proposing to set up a 20 TPD of 3 shifts Bio diesel manufacturing unit.





## BUSINESS STRATEGY

### PESTICIDES BUSINESS;

The Company operates in a competitive market and aims to be a premier pesticides manufacturing company in the country. The Company believes that there is a tremendous growth opportunity in the agro chemical sector and the domain expertise that the Company has obtained in the past will enable the company to compete effectively in this sector and deliver value proposition to the customers and stakeholders. The Company aims to achieve this by implementing the following strategies:

- **Focusing on sales on a region wise basis**

The pesticides industry in India is region-focused. The Company's strategy is to focus on maximizing net sales realization by focusing on sales of its product on a regional basis. The Company's strategy is to focus on saturating the markets which are close to its plant where it enjoys a relative freight advantage. However the growth in the Indian pesticides markets of Andhra Pradesh and neighbouring states has presented a growth opportunity for the Company.

- **Increase in distribution and sales network**

The Company's products are currently marketed through a widespread distribution network comprising of 18 distributors, about 350 dealers and 550 retailers who in turn sell the product to end users such as retailers and farmers. It will continue to focus on building a dedicated and motivated dealer network spread across the state of Andhra Pradesh and the neighbouring states by seeking to add additional dealers to the network and strengthen its relationship with the existing dealers.

- **Increased promotion of Company's brand**

To promote the Company's products and the brand with dealers who are the customers of the Company, the Company organizes meetings with its dealers/customers. The Company also intends to undertake advertising and promotional campaigns in select markets to increase the brand awareness and enhance the understanding of the Company's products. Direct promotional efforts to reach out to contractors and builders would also be done.

- **The Company adopts a multipronged strategy for continuous growth of its business through the following measures:**

- Enhance the quality, design and get up, in accordance with the International Standards.
- Horizontal integration by way of adding new products to the existing products.
- Long term customer relationship and customer satisfaction.
- Need based production.

### BIO-DIESEL:

The first stage of the project is intended primarily to prove the efficiency and benefits of Bio Diesel on the environment, operating costs of the vehicle to the operators, the government, and the general public. Once the users accept the Bio Fuel, as expected, the plant will increase production from 20 tons per day. The expansion will not incur major costs, other than an increase in the working capital and manpower. By the end of the first year of operation, commercialisation of Bio Diesel will be in place.

The Ministry of Petroleum and Natural Gas, India has notified a Bio-diesel Purchase Policy, which provides for purchase of bio-diesel by oil marketing companies at the rate of Rs 25 per litre (inclusive of taxes/duties/transportation cost) with effect from January 1, 2006, at about 20 purchase centers in 12 states. The suppliers should have the capacity to supply minimum 10KL per tanker of bio-diesel meeting prescribed BIS specifications and should be registered with the state level coordinator of oil companies. The blending of bio-diesel at a maximum of 5 percent will be undertaken initially at these 20 centers depending on its availability

In terms of this policy, our company has submitted expression of interest to the designated purchase centre of Indian Oil Corporation, Andhra Pradesh state for supply of Bio Diesel. After commencement of production our company shall supply bio diesel to the designated centre in terms of the Bio diesel purchase policy of India.

In addition to the above our Company has already received letter showing expression of interest (EOI) from the Indian Railways. Discussions with the Andhra Pradesh State Road Transport Corporation, Vijayawada Municipal Corporation, Andhra Pradesh State Lorry Association and some private Companies in the fields of construction,



hospitals, etc. are also in process. These EOIs would be converted into firm Agreements once Bio Diesel production begins.

**Business Strength:**

- i. Location advantage in the agrochemicals business arising from its presence AP
- ii. Moderately long experience of the promoters in agrochemicals trade
- iii. Favourable prospects for biodiesel blending at elevated crude oil prices,.

**Weaknesses:**

- i. Small size of operations and relatively large expansion plans
- ii. High competitive intensity in the agrochemicals business arising from the fragmented nature of the industry
- iii. Earnings and returns from agrochemicals business vulnerable to agro-climatic conditions, likely development of pest resistant Genetically Modified (GM) seeds, seasonal nature of sales, and regulatory risks
- iv. High working capital intensity and seasonality associated with agrochemicals sales
- v. Economics of biodiesel production uncertain because of high jatropha oilseed prices; further, long gestation period for jatropha plantation would impact earnings



## 2. THE ISSUE

Fresh Issue by our Company	1,54,00,000 Equity Shares of Rs.10/- each at a price of Rs 16/- per share for cash aggregating to Rs. 2464Lakhs.
<b>Of which</b>	
Promoters Contribution in this Issue	16,00,000 Equity Shares of Rs.10/- each at a price of Rs 16/- per share for cash aggregating to Rs. 256 Lakhs.
Reservation for Eligible Employees of our Company on competitive basis	10,00,000 Equity Shares of Rs. 10/- each at a price of Rs.16/- per share for cash aggregating to Rs. 160 Lakhs, which comprises 6.49% of the Issue.
<b>Net Issue to the Public</b>	128,00,000 Equity Shares of Rs.10/- each at a price of Rs.16/- per share for Cash aggregating to Rs.2048 Lakhs.
<b>Retail portion (minimum 50% of the net issue to the public)</b>	<b>64,00,000</b> Equity Shares of Rs.10/- each at a price of Rs.16/- per share for Cash aggregating to Rs.1024 Lakhs. <i>(Allocation on a proportionate basis)</i>
<b>Non retail portion (maximum 50% of the net issue to the public)</b>	<b>64,00,000</b> Equity Shares of Rs.10/- each at a price of Rs.16/- per share for Cash aggregating to Rs.1024 Lakhs <i>(Allocation on a proportionate basis)</i>
Equity Shares outstanding prior to the Issue	105,18,200 Equity Shares of Rs.10/- each.
Equity Shares outstanding after the Issue	259,18,200 Equity Shares of Rs.10/- each.
Use of Issue proceeds	Please see the section titled "Objects of the Issue" on page no.28 of this Prospectus

**3. SUMMARY OF FINANCIAL/OPERATING DATA**

The following table sets forth the selected historical financial information of Chemcel Biotech Limited derived from its restated and audited financial statements for the fiscal years ended March 31<sup>st</sup>, 2004, 2005, 2006, 2007 and 2008 all prepared in accordance with Indian GAAP, the Companies Act, and SEBI DIP Guidelines, and restated as described in the Auditor's Report of Mr. T. Nehru, Chartered Accountant, included in the section titled "Financial Information" of this Prospectus and should be read in conjunction with those financial statements and notes thereon.

**STATEMENT OF ASSETS & LIABILITIES RESTATED (Rs. in Lakhs)**

Particulars	For the years ended 31 <sup>st</sup> March				
	2008	2007	2006	2005	2004
<b>Assets:</b>					
<b>Fixed Assets (1)</b>					
Gross Block	165.19	123.83	122.95	123.14	127.83
Less : Depreciation	36.10	25.31	12.84	14.20	14.42
Net Block	129.09	98.52	110.11	108.94	113.41
Add: Capital work in progress	0.00	13.00	580.22		
<b>Total Net Block</b>	129.09	111.52	690.33	108.94	113.41
<b>Deferred Tax</b>	0.32	0.20			
<b>Total</b>	129.41	111.72			
<b>Investment (Non Trade)(2)</b>	<b>3.00</b>			1.00	1.00
<b>Current Assets, Loans and Advances(3)</b>					
Inventories	135.11	130.80	117.75	83.14	150.11
Sundry Debtors **	1126.16	1062.69	660.10	491.86	371.82
Advances to Suppliers	702.76	325.90	445.08	58.05	18.84
Cash and Bank Balances	14.25	1.27	0.49	1.81	3.54
Loans, Advances & Other current assets	719.64	854.97	33.36	57.48	43.10
Total	2697.92	2375.63	1256.78	692.34	587.41
<b>Total Assets (1) + (2) + (3) = 4</b>	<b>2830.33</b>	<b>2487.35</b>	<b>1947.11</b>	<b>802.28</b>	<b>701.82</b>
<b>Less : Liabilities and Provisions</b>					
Secured Loans	665.64	607.96	406.63	285.08	94.91
Unsecured Loans	36.42	36.42	53.16	66.62	100.60
Sundry Creditors	334.78	330.14	161.41	72.88	166.60
Deposits from dealers	9.51	9.63	457.46		
Other Liabilities & Provisions	408.15	244.68	106.48	137.13	231.70
Provisions	46.56	53.05	53.81		
<b>Total (5)</b>	<b>1501.06</b>	<b>1281.88</b>	<b>1238.94</b>	<b>561.71</b>	<b>593.81</b>
<b>Net Worth</b>					
<b>Liabilities (4) – (5)</b>	<b>1329.27</b>	<b>1205.47</b>	<b>708.17</b>	<b>240.57</b>	<b>108.01</b>
Net Worth represented by :					
Share Capital	1051.82	1051.82	664.90	72.00	72.00
Share application money	0.00	—	—	161.60	30.00
Reserves & Surplus	278.50	155.75	46.42	11.17	6.01
Less : Miscellaneous Expenses (to the extent of not written off or adjusted)	-1.05	-2.10	-3.15	-4.20	
<b>Adjusted Net Worth</b>	<b>1329.27</b>	<b>1205.47</b>	<b>708.17</b>	<b>240.57</b>	<b>108.01</b>



\*\* The years 2006-07 and 2007-08 were good monsoon seasons with wide spread rains received throughout the areas with the result farmers have stepped up their agricultural operations substantially during both kharif and Rabi seasons , leading to increased use of agri inputs including pesticides . This has resulted in sharp increase in sales volume also. Our company had made credit sales to the dealers for extending the credit sale to farmers. Further bulk of sales had happened in rabi seasons ( ie October -March ) whose realizations have taken place in the current financial year. Thus as at the end of each financial year ended March 31, 2007 and March 31,2008 the sundry debtor level was high in comparison to the previous years.

The Loans advances include the interest free advance of Rs 540 lakhs made to Jetro Petro Biotech pvt Ltd our subsidiary , for entering into contract with farmers for cultivation of Jatropha Trees, which would be set off against the supplies of Jatropha seeds to our company .

The sundry creditors amount increased during the year 2006-07 and during the current year are due to bulk purchases from the suppliers to meet the increased demand and incidence of provisions for statutory taxes ."

In FY 2005-06 , our company had contemplated to acquire captive land for growing jatropha plants to ensure steady supply of jatropha seeds for the proposed bio diesel plant and paid advance to a few land owners. This amount is shown as capital work in progress as on 31.03.2006 However considering the huge requirement of land and cost involved our company has dropped the land acquisition plan . Instead we have entered into agreement for supply of jatropha seeds from our subsidiary company M/S Jetro Petro Biotech P Limited , who inturn has entered into agreement with 179 farmers for growing jatropha in their lands .

#### **STATEMENT OF PROFIT AND LOSS ACCOUNT AS RE-STATED**

(Rs. in lakhs)

Particulars	For the years ended March 31				
	2008	2007	2006	2005	2004
<b>Income</b>					
Sales	2457.82	2333.69	2137.03	1290.51	1284.14
Other income	0.13	0.93	8.43	0.27	-4.09
Increase / (Decrease) in stocks	4.31	13.04	34.62	-66.97	57.91
<b>Total Income</b>	<b>2462.26</b>	<b>2347.66</b>	<b>2180.08</b>	<b>1223.81</b>	<b>1337.96</b>
<b>Expenditure</b>					
Manufacturing expenses	1862.49	1714.19	1528.30	603.60	617.87
Payment to employees	57.33	48.33	51.31	46.34	54.80
Other Expenditure	83.64	91.72	124.19	183.55	221.98
Selling expenses	174.74	273.98	330.75	305.99	401.31
Interest	107.18	60.03	41.51	23.64	10.45
Depreciation	10.78	12.47	12.84	14.20	14.42
Preliminary exps w/off	1.05	1.05	1.05	0.47	0.17
<b>Total Expenditure</b>	<b>2297.21</b>	<b>2201.77</b>	<b>2089.94</b>	<b>1177.79</b>	<b>1321.00</b>
Profit before tax	165.05	145.89	90.13	46.02	16.96
Current tax	42.4	52.47	14.46	27.64	8.55
Deferred tax	0.11	0.20			
<b>Profit after tax</b>	<b>122.76</b>	<b>93.62</b>	<b>75.68</b>	<b>18.39</b>	<b>8.41</b>
Income tax relating to earlier year					
<b>Net profit</b>	<b>122.76</b>	<b>93.62</b>	<b>75.68</b>	<b>18.39</b>	<b>8.41</b>

**CONSOLIDATED STATEMENT OF PROFIT AND LOSS ACCOUNT AS RE-STATED**

Particulars	For the period ended 31.03.08 (in Lakhs)
<b>Income</b>	
Sales	2457.82
Other income	0.13
Increase / (Decrease) in stocks	4.31
<b>Total Income</b>	<b>2462.26</b>
<b>Expenditure</b>	
Manufacturing expenses	1862.49
Payment to employees	58.71
Other Expenditure	84.09
Selling expenses	174.74
Interest	107.18
Depreciation	10.79
Preliminary exps w/off	1.19
<b>Total Expenditure</b>	<b>2299.19</b>
Profit before tax	163.07
Current tax	38.89
F.B.T.	3.51
Deferred tax	0.11
Minority Interest	0.79
<b>Profit after tax</b>	<b>121.57</b>
Income tax relating to earlier year	
<b>Net profit</b>	<b>121.57</b>

**CONSOLIDATED STATEMENT OF ASSETS & LIABILITIES RESTATED**

(Rs. In Lakhs)

Particulars	For the Period ending on 31.03.08
<b>Assets :</b>	
<b>Fixed Assets (1)</b>	
Gross Block	165.19
Less : Depreciation	36.10
Net Block	129.39
<b>Deferred Tax</b>	0.31
<b>Total</b>	<b>129.70</b>
<b>Investment ( Non Trade) (2)</b>	
<b>Current Assets, Loans and Advances(3)</b>	
Inventories	135.11



Sundry Debtors	1126.16
Advances to Suppliers	702.76
Cash and Bank Balances	14.29
Loans, Advances & Other current assets	722.11
Total	2700.43
<b>Total Assets (1) + (2) + (3) = 4</b>	<b>2830.13</b>
<b>Less : Liabilities and Provisions</b>	
Secured Loans	665.64
Unsecured Loans	36.42
Sundry Creditors	334.78
Deposits from dealers	9.51
Other Liabilities & Provisions	408.35
Provisions	46.56
<b>Total (5)</b>	<b>1501.26</b>
<b>Net Worth.</b>	
<b>Liabilities (4) - (5)</b>	<b>1328.87</b>
Net Worth represented by :	
Share Capital	1051.82
Share Application Money	0.00
Reserves & Surplus	277.32
Minority Interest	1.21
Less : Miscellaneous Expenses (to the extent of not written off or adjusted)	-1.48
<b>Adjusted Net Worth</b>	<b>1328.87</b>

**Notes:** The consolidated restated summary statement of Assets & Liabilities of the Company are not furnished for the financial year ended 31<sup>st</sup> March 2004, 2005, 2006 and 2007 as the Company had invested in the subsidiary company for the first time during the financial year 2007-08.



#### 4. GENERAL INFORMATION

Our Company was incorporated as “Chemcel Products Limited” on September 29, 1995 in Andhra Pradesh vide Registration No. 01-21888 under the Companies Act, 1956 and obtained certificate for commencement of business on October 27, 1995. The registered office of our Company was shifted from 100 Feet Road, Auto Nagar, Vijayawada – 520007 to the present address w.e.f February 17, 1998. The name of our Company was changed from Chemcel Products Limited to Chemcel Bio-Tech Limited w.e.f. January 04, 2001.

<b>Name of our Company</b>	<b>CHEMCEL BIOTECH LIMITED</b>
<b>Registered Office</b>	16-130/12, JRD Tata Industrial Estate, Auto Nagar, Kanuru, Vijayawada – 520 007. <b>Tel:</b> : +91-0866-2540355. <b>Fax:-</b> +91-0866- 2545437 <b>Email:</b> <a href="mailto:ipo@chemcelbiotechltd.com">ipo@chemcelbiotechltd.com</a> <b>Website:</b> <a href="http://www.chemcelbiotechltd.com">www.chemcelbiotechltd.com</a>
<b>Registration No.</b>	01- 21888
<b>Contact Person</b>	Mr. Shaik Rehmatullah-Company Secretary & Compliance Officer
<b>Address of Registrar of Companies</b>	2 <sup>nd</sup> Floor, CPWD Bldg, Kendriya Sadan, Sultan Bazar, Koti, Hyderabad- 500 195 <b>Tel:</b> : +91-040-24657937, 24652807. <b>Fax:-</b> +91-040- 24652807 <b>Email:</b> <a href="mailto:rochyd.sb@sb.nic.in">rochyd.sb@sb.nic.in</a>
<b>CIN</b>	U24120AP1995PLC021888

#### Board of Directors of our Company

<b>Name of the Director</b>	<b>Designation</b>	<b>DIN No</b>	<b>Status</b>
<b>Mr. Kanuparthi Balakrishna Rao</b>	Executive Chairman	01628865	Whole time Director
<b>Mr. Kanuparthi Trinatha Vijaya Kumar</b>	Managing Director	01628916	Managing Director
<b>Mr. Kanuparthi Chandra Shekhar Prasad</b>	Director(Production)	01628889	Whole time Director
<b>Mr. Dhulipala Sankar</b>	Director	01711075	Independent Director
<b>Mr. Polamraju Narasimha Murthy</b>	Director	00973566	Independent Director
<b>Mr. Koka Shri Hari Rao</b>	Director	01782821	Independent Director

#### Brief profile of the Board of Directors

**Mr. Kanuparthi Balakrishna Rao**, aged 70 yrs is a post graduate in Business Management. He started his career with Mysore Fertilizers and worked for more than 20 years and occupied several key posts ranging from finance to Marketing. Later, he joined Coromandal Indag group and was in-charge of Agro chemicals division for Andhra Pradesh. He continued to work here for almost 10 years and resigned from the job in 1994 to start Chemcel. During his stint in Coromandal Indag group, he handled the production of Agro-Chemical Formulations of their Vijayawada Unit and the marketing of Fertilizers and pesticides in the entire Andhra Pradesh.

**Mr. Kanuparthi Trinatha Vijaya Kumar**, aged 51 yrs is a graduate in Commerce and worked with Rallis India Limited in different capacities at Vijayawada for a period of 22 years. He was in-charge of all the marketing activities in Coastal Andhra Pradesh and was directly responsible for sales.

**Mr. Kanuparthi Chandra Shekhar Prasad**, Director (Production) aged 43 yrs holds PG Diploma in Personnel Management. Since the inception of this organization, he is in-charge of Production and Procurement besides General Administration.

**Mr. Dhulipala Sankar**, is an Independent Director of our Company. Aged 61 years, he is an associate of Institute of Chartered Accountants of India. For over 20 years he has worked in Container Accounts department, Finance Division, UAE, Kuwait. Earlier he had been with Shipping Corporation of India, Mumbai for about 6 years. He had also been with Price Water House Peat & Co for about 5 years and Mazagaon Docks Limited, Mumbai for 3 years. He has wide knowledge in Accounting, Taxation, Auditing and Company affairs.





**Mr. Polamraju Narasimha Murthy**, is an Independent Director of our Company. Aged 60 years is a Post Graduate in public Administration, Sugar Technology and is a Qualified in chemical engineering. He has more than 34 years experience in the manufacturing field.

**Mr. Koka Shri Hari Rao is an Independent Director of our Company.** Aged 66 years, he is a Post Graduate, retired as administrative officer from Andhra Pradesh State Meat & Poultry Development Corporation.

Further details of Board of Directors, Please refer to Chapter titled "Our Management" on page no.92 of this Prospectus.

**Issue Management Team:**

**COMPANY SECRETARY & COMPLIANCE OFFICER**

Mr. Shaik Rahmatullah  
16-130/12, JRD Tata Industrial Estate,  
3rd Cross Road Extension,  
Kanuru, Vijayawada – 520007.  
Tel: : +91 866 254 4996  
Fax:- +91 866 254 5437

**Email:** [complianceofficer@chemcelbiotechltd.com](mailto:complianceofficer@chemcelbiotechltd.com)

**Investors may note that in case of any pre Issue/ post Issue related problems such as non-receipt of letters of allotment / share certificates / refund orders, etc. they should contact the Compliance Officer.**

**LEAD MANAGER TO THE ISSUE**

**AllBank Finance Limited**  
(Wholly owned Subsidiary of Allahabad bank)  
Allahabad Bank Building, Second Floor, '37',  
Mumbai Samacharmarg, Fort,  
Mumbai – 400 023  
Tel: + 91 – 22 – 22677552 / 2262 6283  
Fax: + 91 – 22 – 2267 7552  
Email: [chemcel\\_ipo@allbankfinance.com](mailto:chemcel_ipo@allbankfinance.com)  
Website: [www.allbankfinance.com](http://www.allbankfinance.com)  
SEBI Regn No - INM 00006609  
Contact Person: Mr K. Shiv Shankar / Ms.R.Padma

**CO - LEAD MANAGER TO THE ISSUE**

**Ashika Capital Limited**  
1008, 10<sup>th</sup> Floor Raheja Centre, 214,  
Nariman Point,  
Mumbai-400 021.  
Tel : +91 – 22 – 6611 1700;  
Fax: +91 – 22 – 6611 1710  
Email: [mbd@ashikagroup.com](mailto:mbd@ashikagroup.com)  
Website: [www.ashikadirect.com](http://www.ashikadirect.com)  
SEBI Regn. No: INM 00010536  
Contact Person: Mr. Nithin Kanuganti

**REGISTRAR TO THE ISSUE**

**Bigshare Services Private Limited,**  
E-2, Ansa Industrial Estate, Sakivihar Road, Saki Naka,  
Andheri East,  
Mumbai 400 072.  
Tel: +91 – 22 – 40430200/28470652  
Fax: +91 – 22 – 2847 5207  
Email: [ipo@bigshareonline.com](mailto:ipo@bigshareonline.com)  
Website: [www.bigshareonline.com](http://www.bigshareonline.com)  
SEBI Regn.no.INR000001385  
Contact Person : Mr Ashok Shetty, Mr. N.V.K. Mohan



**LEGAL ADVISORS TO THE ISSUE**

**Rajani Associates**

204-207, Krishna Chambers  
59, New Marine Lines  
Mumbai 400020  
Tel: (91 22) 40961000  
Fax: (91 22) 40961010  
Email : [info@rajaniassociates.net](mailto:info@rajaniassociates.net)

**AUDITORS TO OUR COMPANY**

**Mr. T. Nehru.**

Chartered Accountants,  
59-4-2/2, 3<sup>rd</sup> Cross,  
Ashok Nagar, Mogalrajpuram,  
Vijayawada – 520010.  
Tel. No. +91 – 866- 2475 826  
Email: [nehrutatavarthi@yahoo.com](mailto:nehrutatavarthi@yahoo.com)  
Contact Person: Mr.T Nehru

**BANKERS TO OUR COMPANY**

**Union Bank of India**

Vijayawada Main Branch  
Rishab Towers, 1<sup>st</sup> Floor,  
Convent Street, Vijayawada-520 001  
Tel No:: +91 – 866 242 012, 2420 599  
Fax No: +91 – 866 – 2420599  
Website: [www.unionbankofindia.co.in](http://www.unionbankofindia.co.in)

**BANKERS TO THE ISSUE**

**Standard Chartered Bank**

**SEBI Registration no. INB100000885**

D .N. Road,,Fort,  
Mumbai -40001  
Tel No : 022 -22683955  
Fax: 022- 22092216  
**Website : [www.standardchartered.co.in](http://www.standardchartered.co.in)**  
**Contact Person : Mr. Joseph George**  
**Email : [joseph.george@in.standardchartered.com](mailto:joseph.george@in.standardchartered.com)**

**HDFC Bank Ltd**

**SEBI registration No. INB100000063**

BTI Ops Department  
Maneckji Wadia Bldg ,3rd Floor  
Nanik Motwani Marg  
Fort,Mumbai - 400 001  
**Tel : 022-66573746 / 22700272**  
**Fax : 022-22700024**  
**Website : [www.hdfcbank.com](http://www.hdfcbank.com)**  
**Contact Person :Mr Deepak Rane**  
**Email : [Deepak.rane@hdfcbank.com](mailto:Deepak.rane@hdfcbank.com)**

**Axis Bank Limited**

Jeevan Prakash Building  
Sir P.M.Road  
Fort, Mumbai 400 001.  
Tel : 022 – 6610 7265  
Fax : 022 – 2283 5785  
Website : [www.axisbank.com](http://www.axisbank.com)  
Contact Person :Mr. Roshan Mathias  
Email :[roshan.mathias@axisbank.com](mailto:roshan.mathias@axisbank.com)

**Brokers to the Issue**

All the members of the recognized Stock Exchanges would be eligible to act as Brokers to the Issue.

**IPO Grading Agency****ICRA Limited**

Registered Office: 1105, Kailash Building, 11<sup>th</sup> Floor,  
26, Katurba Gandhi Marg, New Delhi-110001  
**Branch office:** 301, Concourse, 3<sup>rd</sup> Floor  
7-1-58, Ameerpet, Hyderabad – 500016  
Tel: (91 40) 23737251 / 23735061  
Fax: (91 40) 23735152  
Email: [info@icraindia.com](mailto:info@icraindia.com)  
Website: [www.icra.in](http://www.icra.in)  
Contact Person: Mr. M.S.K.Aditya

Pursuant to the clauses 2.5A, 5.6 B and 6.17..3.A of the SEBI guidelines this Issue has been graded by ICRA Ltd and has been assigned the “IPO Grade 1” indicating poor fundamentals, vide its letter ref: ICRA/CBL/2008-09/2006 dated June 25, 2008. The IPO grading is assigned on a five point scale from 1 to 5 with an “IPO Grade 5” indicating strong fundamentals and an “IPO Grade 1” indicating poor fundamentals. The grading was revalidated vide its letter no ICRA/CBL/2008-09/2208 dated August 22, 2008 for a period of 6 months from the date of the revalidation letter. A copy of the report provided by ICRA furnishing the rationale for its grading is available for inspection at our Registered Office from 10.00 am to 4.00 pm on Working Days from the date of this Prospectus until the Issue Closing Date.

A summary of the rationale for the grading assigned by ICRA to the Issue is extracted below:

The IPO Grade 1 assigned by ICRA reflects CBL’s small scale of operations, the high intensity of competition in the fragmented agrochemicals industry, the company’s extremely high working capital intensity, the vulnerability of its earnings to agro-climatic conditions and development of pest resistant GM crops, the uncertainty over the viability of the biodiesel venture because of issues relating to availability and price of the feedstock and its below average corporate governance practices. However, ICRA also believes that CBL benefits from its proximity to the large pesticides market in AP and the considerable experience of its promoters in the agrochemicals business. CBL is a marginal player in the fragmented agrochemicals industry, characterised by low capital intensity (in formulations). However, the company has an advantage of being located in coastal AP, one of the largest pesticides markets in India. The business is vulnerable to agro-climatic risks and seasonality, which results in high working capital intensity. CBL’s capacity utilisation remains on the lower side because of its focus solely on coastal AP and its limited product portfolio. Being a small player, the company has very limited pricing power and is vulnerable to margin pressures because of high competition and the dependence of its product portfolio on relatively old molecules. CBL is also exposed to risks from GM crops, which are resistant to pests. In India, the cultivation area for Bt cotton is already around 2/3rd the total cotton area and the ratio is expected to increase over the next few years. This trend has led to a decline in pesticides consumption in cotton and is of significance, given CBL’s high exposure to cotton. However, this risk is partly mitigated by the emergence of new pests that attack GM crops and the overall increasing cotton acreage. Going forward, CBL plans to introduce new products (for which it already has registrations) and expand into other AP districts and southern States, to achieve higher capacity utilisation. CBL is setting up a jatropha based biodiesel plant at Kondapalli with a capacity of 6,000 tonnes per annum (tpa). Currently, the Indian Government is encouraging biodiesel production through non-edible oils (in view of the country’s deficiency in edible oils), and jatropha is being largely considered as the best option, given its ability to grow on degraded wastelands not suitable for foodcrops. While biodiesel blending would remain vulnerable to crude oil prices, the currently high crude oil



prices should make biodiesel blending profitable for oil marketing companies (biodiesel blending could become unviable at lower crude oil prices). Further, use of biodiesel has larger socio-economic benefits such as pollution control, employment generation and conversion of arid land for productive purpose, because of which it has gained importance. State Governments have introduced various incentives for cultivation of jatropha, while the Central Government is expected to come out with a national biodiesel policy in the short term. A key constraint in increasing use of biodiesel is lack of sufficient availability of jatropha oilseeds, given the long cultivation period of four to five years. Although the AP Government has fixed minimum support prices for jatropha oilseeds at Rs. 6 per kg, market prices are much higher because of the limited supply. This has resulted in the cost of biodiesel production being much higher than the price mandated by the Government (Rs. 26.5/litre). However, in future, higher yields on larger cultivations and the resulting larger supply are expected to bring down oilseed prices. CBL has, through its subsidiary Jetro Petro Biotech Limited (JPBL), entered into a nine-year seed procurement agreement with 179 farmers holding 2,200 acres of land. JPBL has paid around Rs. 54 million as advances to these farmers, and the sum is recoverable from future oilseed purchases from the farmers. However, since CBL would require significantly higher acreage to achieve optimum capacity utilisation, it plans to enter into new agreements with more farmers. CBL's ability to ensure adequate feedstock arrangement (to achieve optimum capacity utilisation) at the right price remains to be seen in a scenario of limited supply. Overall, the returns from CBL's venture into biodiesel could be constrained by its small scale, high oilseed prices and the fixed price at which oil marketing companies are to purchase biodiesel.

#### ICRA Grading Perspective Chemcel Biotech Limited ICRA Rating Services

As for CBL's litigation history, there are several cases pending, in which its promoters are involved in litigation against Rallis India Limited (Rallis). The latter has alleged inappropriate appointment of two dealers by Mr. Mr. Kanuparthi Trinadha Vijaya Kumar (MD of CBL) during the latter's tenure with Rallis. The promoters of CBL have also filed a defamation case against Rallis. These cases are at various stages of hearing. CBL's revenues reported a compounded annual growth rate (CAGR) of 42% over 2003-07, with sales rising by 108% in 2005-06 following the company's expansion into newer regions and the introduction of bio-products. While CBL's revenue and operating margins have fluctuated because of pest incidence and competition, in 2006-07 (9.79%) and in the first nine months (9M) of 2007-08, its operating margins showed an upward trend (12.48%) following the introduction of some higher margin products and subsequently an increase in capacity utilisation. Because of the low capital intensity associated with the formulations business, CBL's return on capital employed (RoCE) remained high in the past. Its return on net worth (RoNW) declined sharply from 14.9% in 2005-06 to 9.78% in 2006-07 because of equity infusion (of Rs. 98 million) by the promoters, which has gone largely towards the biodiesel project and is yet to generate returns. CBL's gearing declined from 1.46 times as on March 31, 2005 to 0.53 time as on March 31, 2007 because of the equity infusion. Its working capital intensity, as measured by ?net working capital/operating income?, remained much higher than the industry average at 52% in 2005-06 and 74% in 2006-07. The longer credit period on certain newer products and higher sales in the rabi season led to a sharp rise in its debtor days, leading to consistently negative operating cash flows in the recent past. Going forward, ICRA expects CBL to be able to increase its agrochemicals sales moderately, given its expansion into newer regions and the introduction of certain newer products. However, high competition and declining prices of products (largely old molecules) are likely to constrain margin expansion (because of higher capacity utilisation). Given the long cultivation period for jatropha and consequently the low oilseed availability, CBL's biodiesel plant is expected to run at low capacity utilisation in the initial years. As a result, returns from the biodiesel venture should remain suppressed over the medium term.

#### Disclaimer by ICRA :

Notwithstanding anything to the contrary: An ICRA IPO grade is a statement of current opinion of ICRA and is not a statement of appropriateness of the graded security for any of the investors. Such grade is assigned with due care and caution on the basis of analysis of information and clarifications obtained from the issuer concerned and also other sources considered reliable by ICRA. However, ICRA makes no representation or warranty, express or implied as to the accuracy, authenticity, timeliness, or completeness of such information. An ICRA IPO grade is not (a) a comment on the present or future price of the security concerned (b) a certificate of statutory compliance and/or (c) a credit rating. Further, the ICRA IPO grade is not a recommendation of any kind including but not limited to recommendation to buy, sell, or deal in the securities of such issuer nor can it be considered as an authentication of any of the financial statements of the company, and ICRA shall not be liable for any losses incurred by users from any use of the grade in any manner. It is advisable that the professional assistance be taken by any prospective investor in the securities of the company including in the



fields of investment banking, tax or law while making such investment. All services and information provided by ICRA are provided on an “as is” basis, without representations and warranties of any nature.

### **Credit Rating**

This being a public issue of equity shares no credit rating is required.

### **Trustee**

This being an issue of Equity Shares, appointment of Trustee is not required.

### **MONITORING AGENCY:**

In terms of Clause 8.17 of the SEBI DIP Guidelines, 2000, as amended there is no requirement of Monitoring Agency. However, our Board of Directors will monitor the utilization of the proceeds of the Fresh Issue. Our company has set up the Audit Committee comprising of non-executive and independent directors and pursuant to Clause 49 of the listing agreement, we shall, on a quarterly basis, disclose to the Audit Committee the uses and application of the proceeds of the Fresh Issue. We will disclose the utilization of the proceeds of the issue under a separate head in our Balance Sheet, till such time the proceeds of the Issue have been utilized fully, clearly specifying the purpose for which such proceeds have been utilized. We will also, in our Balance Sheet, till such time the proceeds of the Issue have been fully utilized, provide details if any, in relation to all such proceeds of the Issue that have not been utilized thereby also indicating investments, if any, of such unutilized proceeds of the Issue.

### **Underwriters to the issue**

The equity shares offered are not being underwritten.

### **Minimum Subscription**

If our Company does not receive the minimum subscription of 90% of the net offer to public on the date of closure of the Issue, or if the subscription level falls below 90% after the closure of Issue on account of cheques having being returned unpaid or withdrawal of applications, our Company shall forthwith refund the entire subscription amount received. If there is a delay beyond 8 days after our Company becomes liable to pay the amount, our Company shall pay interest as per Section 73 of the Companies Act, 1956. No statement made in this offer document shall contravene any of the provisions of the Companies Act, 1956

### **Statement of Inter-se allocation of responsibilities:**

The following table sets forth the inter se allocation of responsibilities for various activities between All Bank Finance Limited (Allbank) and Ashika Capital Limited (Ashika) as the Lead Managers for the Issue: The selection of various agencies including the Registrar to the Issue, Bankers to the Issue, Bank collection centres, Advertising agencies will be or have finalised by our Company in consultation with the Lead Managers.

<b>No.</b>	<b>Activity</b>	<b>Responsi- bility</b>	<b>Coordi- nation</b>
1.	Capital structuring with the relative components and formalities such as type of instruments, etc.	Allbank	Allbank
2.	Conducting a Due diligence of our Company's operations / management / business plans / legal, etc. Drafting and designing the Draft Prospectus/ Prospectus. Ensuring compliance with the Guidelines for Disclosure and Investor Protection and other stipulated requirements and completion of prescribed formalities with the Stock Exchanges, RoC and SEBI.	Allbank	Allbank
3.	Primary co-ordination with SEBI, RoC and Stock Exchanges up to application and coordinating interface with lawyers for agreements.	Allbank	Allbank



4.	Primary coordination of drafting/proofing of the design of the Prospectus, application forms including memorandum containing salient features of the Prospectus with the printers. Primary coordination of the drafting and approving the statutory advertisement.	Allbank	Allbank
5.	Drafting and approving all publicity material other than statutory advertisement as mentioned in (4) above including corporate advertisement, brochure, etc.	Allbank	Allbank
6.	Appointment of the Registrar, Bankers to the issue and appointment of other intermediaries viz. printers and advertising agency	Allbank,	Allbank
7.	Marketing of the Issue, which will cover inter alia: <ul style="list-style-type: none"><li>• Formulating marketing strategies, preparation of publicity budget,</li><li>• Finalizing media &amp; public relations strategy,</li><li>• Finalizing centers for holding conferences for press and brokers etc.</li><li>• Finalizing collection centers,</li><li>• Coordinating investor meetings</li><li>• Following-up on distribution of publicity and Issue material including form, prospectus and deciding on the quantum of the Issue material</li><li>• Preparing all road show presentations</li></ul>	Ashika	Ashika
8.	Finalizing the Prospectus and RoC filing	Allbank	Allbank
9.	Follow – up with the bankers to the issue to get quick estimates of collection and advising the issuer about closure of the issue, based on the correct figures.	Allbank	Allbank
10.	The post-Issue activities for the Issue will involve essential follow up steps, which include finalizing basis of allotment / weeding out of multiple applications, the listing of instruments and dispatch of certificates and dematerialized delivery of shares with the various agencies connected with the work such as the Registrars to the Issue and Bankers to the Issue and the bank handling refund business. The Lead Managers shall be responsible for ensuring that these agencies fulfill their functions and enable it to discharge this responsibility through suitable agreements with our Company.	Allbank	Allbank



## 5. CAPITAL STRUCTURE

	Particulars	Nominal Value (Rs.)	Aggregate value at issue price( Rs )
A	<b>AUTHORIZED:</b> 3,00,00,000 Equity Shares of Rs. 10/- each	30,00,00,000	
B	<b>ISSUED, SUBSCRIBED &amp; PAID UP SHARE CAPITAL</b> 1,05,18,200 Equity Shares of Rs. 10/- each	10,51,82,000	
C	<b>PRESENT ISSUE</b> 1,54,00,000 Equity Shares of		
	Rs.10/- each for cash at a premium of Rs.6/- per share	15,40,00,000	24,64,00,000
	<b>Out of which</b>		
	16,00,000 Equity Shares of Rs.10/- each for cash at a premium of Rs 6/- per share reserved for Promoters	160,00,000	2,56,00,000
	10,00,000 Equity shares of Rs 10 each on competitive basis for cash at a premium of Rs.6/- per share reserved for Eligible Employees of our company #	100,00,000	1,60,00,000
D	<b>Net Offer to the Public 128,00,000</b> Equity Shares of Rs.10/- each for cash at a premium of Rs.6/- per share	<b>12,80,00,000</b>	20,48,00,000
E	<b>PAID-UP CAPITAL AFTER THE PRESENT ISSUE</b> <b>2,59,18,200</b> equity shares of Rs.10/- each	<b>25,91,82,000</b>	35,15,82,000
F	<b>SHARE PREMIUM ACCOUNT</b>		
	<b>Before the Issue</b>	Nil	
	<b>After the Issue</b>	9,24,00,000	

# With employee reservation portion the holding of the promoters shall not increase directly or indirectly. For Eligible Employee, see the section "Definitions and Abbreviations - Issue Related Terms - Employee or Eligible Employee" beginning on page no. iii of this Prospectus



## NOTES TO CAPITAL STRUCTURE

## 1. The current Capital Structure of our Company has been built-up as under

Date of Allotment/ fully paid-up	No. of Shares	Face Value	Cumulative no. of shares	Issue Price (Rs.)	Consideration	Remarks / Allotment
At Incorporation Sept 22,1995	70	10/-	70	10/-	Cash	Subscription to the Memorandum
July 25,1996	4000	10/-	4070	10/-	Cash	Allotted to promoters
Aug 25,1996	36000	10/-	40070	10/-	Cash	-- Do --
Mar 25,1997	20000	10/-	60070	10/-	Cash	-- Do --
July 16,1997	46000	10/-	106070	10/-	Cash	Allotted to promoters
Sept 18,1997	111000	10/-	217070	10/-	Cash	-- Do --
Mar 02,2000	130500	10/-	347570	10/-	Cash	-- Do --
Aug 29,2001	83260	10/-	430830	10/-	Cash	-- Do --
Mar 24,2002	24000	10/-	454830	10/-	Cash	-- Do --
Nov 15,2003	145171	10/-	600001	10/-	Cash	-- Do --
Mar 25,2004	119999	10/-	720000	--	Bonus	Capitalisation of reserves in the ratio of 1:5
Apr 30,2005	300000	10/-	1020000	10/-	Cash	Allotted to Promoters
Jan 09,,2006	180000	10/-	1200000	10/-	Cash	-- Do --
Jan 25,,2006	5449000	10/-	6649000	10/-	Cash	Promoters & their associates
Oct 07,2006	589800	10/-	7238800	10/-	Cash	Allotment on preferential basis to friends and associates
Oct 15,2006	1115000	10/-	8353800	10/-	Cash	Allotment on preferential basis to friends and associates
Nov 01,2006	1174000	10/-	9527800	10/-	Cash	Allotment on preferential basis to friends and associates
Nov 25,2006	409800	10/-	9937600	10/-	Cash	Allotment on preferential basis to friends and associates
Dec 15,2006	181000	10/-	10118600	10/-	Cash	Allotment on preferential basis to friends and associates
Jan 02, 2007	175100	10/-	10293700	10/-	Cash	Allotment on preferential basis to friends and associates
Feb 03,2007	52000	10/-	10345700	10/-	Cash	Allotment on preferential basis to friends and associates
Mar 28,2007	172500	10/-	10518200	10/-	Cash	Allotment on preferential basis to friends and associates
(.)proposed issue	154,00,000	10/-	<b>259,18,200</b>	16/-	Cash	Proposed public issue at a price of Rs.16/- per share





## 1. Details of increase in authorized capital

No.	Particulars of Increase	Date of Meeting
1	Rs.50,00,000	Incorporation
2	From Rs.50,00,000 to Rs.1,20,00,000	Apr 30, 2003
3	From Rs.1,20,00,000 to Rs. 26,20,00,000	Dec 29, 2005
4	From Rs. 26,20,00,000 to Rs. 30,00,00,000	Nov 15, 2006

## 2. Promoters contribution and lock in:

Pursuant to SEBI DIP Guidelines, an aggregate of 20% of the post-issue Equity Share Capital of our Company shall be locked-in by our Promoters for a period of 3 years from the date of allotment in this Issue.

Name of the Promoter	Date of Allotment/ Transfer	Nature of Payment	No.of shares	Face Value (Rs.)	Issue/ Transfer Price	%post issue capital	Lock in Period*
Mr. K.Balakrishna Rao	Sep22,1995	Cash	10	10	10		1 year
	Jul 25.,1996	Cash	500	10	10		1 year
	Aug 25,1996	Cash	18000	10	10		1 year
	Mar 25,1997	Cash	12500	10	10		1 year
	Jul 16, 1997	Cash	9000	10	10		1 year
	Sept 18,1997	Cash	20000	10	10		1 year
	Mar 02,2000	Cash	30000	10	10		1 year
	Aug 29,2001	Cash	25850	10	10		1 year
	Jan 24, 2002	Cash	14000	10	10		1 year
	Nov 15,2003	Cash	35920	10	10		1 year
	Mar 25,2004	Bonus	33156	10	-		1 year
	Apr 30, 2005	Cash	150000	10	10		1 year
	Jan 09, 2006	Cash	90000	10	10		1 year
	Jan 25, 2006	Cash	340000	10	10	1.31%	3 years
Transfer to employees	Sept 1, 2006	Cash	10000	10	10		
Transfer to Prabhavathi	Nov 4, 2006	Cash	1300	10	10		
	May 15, 2007	Cash	1027500	10	10		1 year
	<b>Total No of Shares Before the Issue</b>		<b>1795136</b>			<b>6.93%</b>	
	Proposed Subscription	Cash	<b>800000</b>	<b>10</b>	<b>16</b>	<b>3.09%</b>	<b>3 years</b>
	<b>Total No of shares After the Issue</b>		<b>2595136</b>			<b>10.02%</b>	
Mr. Kanuparthi Trinatha Vijaya Kumar	Sep22, 1995	Cash	10	10	10		1 year
	Sep22, 1995	Cash	1000	10	10		1 year
	Jul 25, 1996	Cash	12000	10	10		1 year
	Aug 25,1996	Cash	6000	10	10		1 year
	Mar 25,1997	Cash	7500	10	10		1 year
	Jul 16,1997	Cash	17000	10	10		1 year



Name of the Promoter	Date of Allotment/ Transfer	Nature of Payment	No. of shares	Face Value (Rs.)	Issue/ Transfer Price	% post issue capital	Lock in Period*
	Sept 18,1997	Cash	84000	10	10		1 year
	Mar 02,2000	Cash	55000	10	10		1 year
	Aug29,2001	Cash	32577	10	10		1 year
	Nov 15,2003	Cash	57971	10	10		1 year
	Mar 25,2004	Bonus	54611	10	0		1 year
	Apr 30,2005	Cash	150000	10	10		1 year
	Jan 09,2006	Cash	90000	10	10		1 year
	Jan 25,2006	Cash	2402500	10	10	9.27%	3 years
<b>Transferred to Employees</b>	Nov 4, 2006	Cash	2000	10	10		
	Total No of Shares Held Before the Issue		<b>2968169</b>			<b>11.45%</b>	
	Proposed Subscription	Cash	<b>800000</b>	<b>10</b>	<b>16</b>	<b>3.09%</b>	<b>3 years</b>
	Total No. of Shares After the Issue		<b>3768169</b>			<b>14.54%</b>	
<b>Mr. Kanuparthi Chandra Shekhar Prasad</b>	Jul 25., 1996	Cash	500	10	10		1 year
	Sept 18,1997	Cash	5000	10	10		1 year
	Mar 02,2000	Cash	20000	10	10		1 year
	Aug29,2001	Cash	3125	10	10		1 year
	Jan 24.,2002	Cash	4100	10	10		1 year
	Nov 15,2003	Cash	9060	10	10		1 year
	Mar 25,2004	Bonus	8357	10	0		1 year
	Jan 25,2006	Cash	1042500	10	10	4.02%	3 years
	Total No. of Shares		<b>1092642</b>			<b>4.22%</b>	
	Grand Total		<b>7455947</b>			<b>28.78%</b>	

**LOCK IN OF Promoters Shares for 3 years**

Name of the Promoter	Date of Allotment/ Transfer	Nature of Payment	No. of Shares	Face Value (Rs.)	Issue/ Transfer Price (Rs.)	% post issue capital
<b>1. Mr. K. Balakrishna Rao</b>	Jan 25,2006	Cash	340000	10	10	1.31
	Participation in proposed issue as promoters contribution	Cash	800000	10	16	3.09
<b>Sub Total</b>			<b>1140000</b>			<b>4.40</b>
<b>2. Mr. Kanuparthi Trinatha Vijaya Kumar</b>	Jan 25,2006	Cash	2402500	10	10	9.27



	Participation in proposed issue as promoters contribution	Cash	800000	10	16	3.09%
Sub total			<b>3202500</b>			<b>12.36</b>
<b>3.Mr. Kanuparthi Chandra Shekhar Prasad</b>	Jan 25,2006	Cash	1042500	10	10	4.02
<b>Subtotal</b>			<b>1042,500</b>	<b>4.02</b>		
<b>TOTAL</b>			<b>5385000</b>			<b>20.78</b>

53,85,000 shares from the three promoters i.e. **Mr.K.Balakrishna Rao, Mr. K.T.Vijaya Kumar and Mr K.C.S.Prasad** would be locked-in for a period of three years which constitutes 20.78% of the post issue paid up capital of our company and the balance Pre-Issue paid-up Equity Share Capital would be locked-in for a period of one year. The lock-in period shall commence from the date of allotment of Equity Shares in the present Issue or the date of commencement of commercial production, whichever is later. Written consent has been obtained from the persons whose shares form part of promoters' contribution and are subject to lock in period. Other than the above, Other than the above the entire pre-issue capital of our Company shall be subject to lock in of one year from the date of allotment of shares in this issue.

- The Equity Shares allotted / held by the Promoters of our Company are fully paid- up.
- Further all the Equity Shares, which are being locked in for three years, are not ineligible for computation of promoter's contribution and lock in as per clause 4.6 of SEBI Guidelines.
- In terms of Clause 4.14.1 of the SEBI Guidelines, in addition to the lock-in of 20% of the post-Issue shareholding of the Promoters for three years, as specified above, the balance pre-Issue share capital of the Company shall be locked-in for a period of one year from the date of Allotment in the Issue. The promoters have given an undertaking to not sell/transfer/dispose of in any manner, Equity Shares forming part of the Promoters' contribution from the date of filing the Prospectus till the date of commencement of lock-in as per the SEBI Guidelines.
- In terms of Clause 4.15 of the SEBI Guidelines, the locked-in Equity Shares held by the Promoters can be pledged only with banks or financial institutions as collateral security for any loans granted by such banks or financial institutions, provided that the pledge of shares is one of the conditions under which the loan is sanctioned. Further, Equity Shares locked in as minimum promoters' contribution may be pledged only in respect of a financial facility which has been granted for the purpose of financing one or more of the objects of the Issue.

(Provided that if securities are locked in as minimum promoters' contribution under clause 4.11.1, the same may be pledged, only if, in addition to fulfilling the requirements of this clause, the loan has been granted by such banks or financial institutions for the purpose of

financing one or more of the objects of the issue.)

- In terms of Clause 4.16.1 (a) of the SEBI Guidelines, the Equity Shares held by persons other than Promoters prior to the Issue may be transferred to any other person holding the Equity Shares which are locked-in as per Clause 4.14 of the SEBI Guidelines, subject to the continuation of the lock-in in the hands of the transferees for the remaining period and compliance with the SEBI (Substantial Acquisition of Shares and Takeovers) Regulations, 1997, as applicable.
- Further, in terms of Clause 4.16.1(b) of the SEBI Guidelines, the Equity Shares held by the Promoters may be transferred to and among the Promoter Group or to a new promoter or persons in control of the Company subject to continuation of the lock-in in the hands of the transferees for the remaining period and compliance with the SEBI (Substantial Acquisition of Shares and Takeovers) Regulations, 1997, as applicable.



Our Company confirms that the Promoter contribution does not consist of:

- Shares acquired for consideration other than cash and revaluation of assets or capitalization of intangible assets or bonus shares out of revaluation reserves or reserves without accrual of cash resources.
- Pledged securities held by the promoters (in terms of provisions of clause 4.6.4 A of SEBI (DIP) guidelines.
- Securities issued during the preceding one year, at a price lower than the price at which equity shares is being offered to public.
- Private placement made by solicitation of subscription from unrelated persons either directly or through any intermediary.
- Shares for which specific written consent has not been obtained from the respective shareholders for inclusion of their subscription in the minimum promoter's contribution subject to lock-in.
- Shares issued to promoters on conversion of partnership firms into limited company.
- Shares with a contribution less than Rs.25,000/- per application from each individual and contribution less than Rs.1,00,000/- from firms and companies.

#### 4. Pre-issue and post issue shareholding pattern

Name of the Shareholder	Pre-Issue		Post-Issue	
	% Holding	No. of Shares	% Holding	Promoters
K.Balakrishna Rao	1795136	17.07	2595136	10.02
K.T.Vijay Kumar	2968169	28.22	3768169	14.54
K.C.S.Prasad	1092642	10.39	1092642	4.22
<b>Sub total (a)</b>	<b>5855947</b>	<b>55.68</b>	<b>7455947</b>	<b>28.78</b>
<b>Promoters Group</b>				
K.Ramachandra Rao	1212	0.01	1212	0.00
K.Kalyani	70333	0.67	70333	0.27
K.Sujatha	53130	0.51	53130	0.20
K.S.Lakshmi	18554	0.18	18554	0.07
K. Prabavathi	10000	0.10	10000	0.04
K.Vani	10000	0.10	10000	0.04
<b>Sub total (b)</b>	<b>163229</b>	<b>1.57</b>	<b>163229</b>	<b>0.62</b>
Total of (a)+(b)	<b>6019176</b>	<b>57.23</b>	7619176	29.40
Others				
<b>Friends and Associates</b>	4499024	42.77	4499024	<b>17.36</b>
<b>Sub total I</b>	<b>4499024</b>	<b>42.77</b>	<b>4499024</b>	<b>17.36</b>
<b>Total Shareholding I =</b>				
<b>(a)+ (b)+(c)</b>	<b>10518200</b>	<b>100.00</b>	<b>12118200</b>	<b>46.76</b>
<b>II. Public Issue ( other than promoters contribution)</b>				
<b>Of whichi. Employees reservationii. Net Public issue</b>			<b>1000000</b>	<b>3.86</b>
			<b>12800000</b>	<b>49.38</b>
<b>Total I+II</b>	<b>10518200</b>	<b>100.00</b>	<b>25918200</b>	<b>100.00</b>



**5. Top Ten Shareholders Two years prior to the filing of Prospectus:**

No	Name	No of Shares	% to Issued Capital
1	K.T.Vijay Kumar	477669	46.83
2	K.Balakrishna Rao	348936	34.21
3	K.Kalyani	70333	6.90
4	K.Sujatha	53130	5.21
5	K.C.S.Prasad	50142	4.92
6	K.S.Lakshmi	18554	1.82
7	K.Ramachandra Rao	1212	0.12
8	B.K.Sharma	12	0.00
9	V.Sekhar	12	0.00
	<b>TOTAL</b>	<b>1020000</b>	<b>100.00</b>

**Note:** There were only nine share holders two years prior to the date of Prospectus

**6. Particulars of top ten shareholders as on the date of filing of the Prospectus with SEBI.**

S.No	Name	No of Shares	% to Issued Capital
1	K.T.Vijay Kumar	2968169	28.22
2	K.Balakrishna Rao	1795136	17.07
3	K.C.S.Prasad	1092642	10.39
4	K.Ramakrishna	301000	2.86
5	M.V.R.Sastry	200000	1.90
6	M V S Anantha Krishnan	150000	1.43
7	Marty Venkata Rama Sastry	150000	1.43
8	K.Siva Kishore	110000	1.05
9	B. Srinivasa Reddy	100000	0.95
10.	B. Ravi Shankar Reddy	100000	0.95
	<b>TOTAL</b>	<b>6966947</b>	<b>66.24</b>

**7. Particulars of top ten shareholders as on ten days prior to the date of filing of the Prospectus with SEBI.**

S.No	Name	No. of Shares	% of Issued capital
1	K.T.Vijay Kumar	2968169	28.22
2	K.Balakrishna Rao	1795136	17.07
3	K.C.S.Prasad	1092642	10.39
4	K.Ramakrishna	301000	2.86
5	M.V.R.Sastry	200000	1.90
6	M V S Anantha Krishnan	150000	1.43
7	Marty Venkata Rama Sastry	150000	1.43
8	K.Siva Kishore	110000	1.05
9	B. Srinivasa Reddy	100000	0.95
10.	B. Ravi Shankar Reddy	100000	0.95
	<b>TOTAL</b>	<b>6966947</b>	<b>66.24</b>



8. As on date, Promoters/Promoter Group holds 60,19,176 Equity Shares aggregating to 57.23% of the total paid up capital. The Promoters/Promoter Group and Directors of our company have not purchased or sold the Equity Shares of our Company during the period of six months preceding the date of filing of this Prospectus with SEBI,
9. Our Company, its Promoters, its directors and the Lead Manager to this Issue have not entered into any buy back and/ or stand by arrangements for purchase of equity shares of our Company from any person in respect of this Issue. No payment, direct or indirect in the nature of discount, commission, allowance or otherwise shall be made either by us or our promoters to the persons who receive allotments, if any, in this Issue.
10. There are no outstanding warrants, options or rights to convert debentures or other instruments into equity shares as on date.
11. Our Company does not currently have any Employee Stock Option Plan.
12. Our Company has availed a short term loan of Rs 120.00 Lakhs against the proceeds of this Issue from Union Bank of India, Vijayawada branch . The details of the loan have been mentioned in section objects of the issue starting from page no.28 of the Prospectus.
13. Our Company has 415 members/shareholders as on date.
14. No single applicant can make an application for number of securities, which exceeds the securities offered through this Issue.
15. Our Company has not issued any shares out of revaluation reserves. We have not revalued our assets since inception.
16. Since the entire money of Rs. 16/- per share (Rs. 10/- face value + Rs. 6/- premium) is being called on application, all the successful applicants will be issued fully paid-up shares. The securities offered through this public issue shall be made fully paid-up or may be forfeited within 12 months from the date of allotment of securities, if not made fully paid-up, in the manner specified in clause 8.6.2 of the SEBI DIP guidelines.
17. The Equity Shares of our Company are fully paid up and there are no partly paid up shares as on date.
18. The equity shares of our Company shall be available in dematerialized mode and the market lot is one equity share. Our Company undertakes that at any given time there shall be only one denomination for the shares of our Company and our Company shall comply with such disclosure and accounting norms specified by SEBI from time to time.
19. Our Company has issued 1,19,999 Equity Shares by way of Bonus Shares by capitalization of free reserves on 25<sup>th</sup> March, 2004. Except for the above, no shares were issued for consideration other than cash.
20. Our Company undertakes that there would be no further issue of capital whether by way of issue of bonus shares or rights issue during the period commencing from submission of the Prospectus with SEBI until the equity shares offered through this Prospectus have been listed. We presently do not have any intention or proposal to alter our capital structure for a period of six months from the date of opening of this Issue, by way of split/ consolidation of the denomination of Equity Shares or further issue of Equity Shares (including issue of securities convertible into exchangeable, directly or indirectly, for our Equity Shares) whether preferential or otherwise, except that if we enter into acquisitions or joint ventures, we may consider raising additional capital to fund such activity or use Equity Shares as currency for acquisition or participation in such joint ventures
21. No shares have been allotted on firm basis or through private placement in the last two years nor has our Company bought back its equity shares in the last six months.
22. An over-subscription to the extent of 10% of the net offer to public can be retained for the purpose of rounding off to the nearest integer subject to a minimum allotment being equal to 350, which is the minimum application size in this Issue, while finalizing the allotment.



23. Post-issue, the Promoters/Promoter Group holding will be 29.40%.
24. The equity shares to be held by the Promoters under the lock-in period shall not be sold/hypothecated/transferred during the lock-in period. However, inter-se transfers between the Promoters themselves as such would be permitted, provided that the requirement of lock-in period guidelines continues to apply, to the extent initially prescribed. The securities which are subject to lock-in shall carry the inscription “non-transferable” and the non-transferability details shall be informed to the depositories. The details of lock-in shall also be provided to BSE where the shares are to be listed, before the listing of the securities.
25. The locked-in equity shares held by the Promoters can be pledged only with Banks/Financial Institutions, provided the pledge of shares is one of terms of sanction letter.
26. As per SEBI DIP Guidelines, a minimum of 50% of the net offer to the public is reserved for allotment to individual investors applying Equity Shares of or for a value of not more than Rs.1,00,000/-. The remaining 50% of the offer to the public is reserved for individuals, corporate bodies/institutions, etc applying for Equity Shares for a value more than Rs.1,00,000/-. Unsubscribed portion in either of these categories shall be added to the other category interchangeably.
27. An applicant in the net offer to public category cannot make an application for a number of securities, which exceeds the Net Offer to the Public.
28. Undersubscribed portion in any reserved category may be added to any other reserved category. The unsubscribed portion, if any, after such inter-se adjustments amongst the reserved category shall be added back to the net offer to the public.
29. In case of under-subscription in the Net Offer to the Public portion, spillover to the extent of undersubscription shall be permitted from the reserved category to the net offer to the public.
30. In case of over-subscription, allotment will be on proportionate basis as defined in para on ‘Basis of Allotment’.
31. The Equity Shares offered through this public issue will be fully paid up.
32. None of the natural persons, who are in control of the corporate entities forming the “Promoter Group” of our Company, have been restrained from accessing the Capital Market for any reasons by SEBI or any other authorities
33. At any given point of time, there shall be only one denomination for the Equity Shares of our Company and we shall comply with such disclosure and accounting norms specified by SEBI from time to time.
34. Restrictive Covenants under the lender’s agreements about capital structure: In respect to the various agreements entered into by our Company with its lenders, we are bound by certain restrictive covenants regarding our capital structure. As per these restrictive covenants, our Company cannot, without the prior approval of the Bank, prepay any outstanding loan amount, issue any debentures, raise loans, deposits from public, issue equity or preference capital, issue bonus shares, change its capital structure or create any charge on its assets or give any guarantees. Also we shall not without the prior written approval of the Banks/FIs buy back, cancel, retire, reduce, redeem, purchase, re-purchase, acquire any of its share capital, issue any further share capital. Further, our Company is also prohibited from creating any subsidiary or undertaking mergers, amalgamations and re-organizations with the creditors or shareholders, without the prior consent of its lending institutions. Also, our Company shall not, without the prior permission of its lender, invest any part of the loan money advanced, by way of deposits, loans, share capital or otherwise in any concern. Our Company shall not declare or pay any dividend to its shareholders during any financial year unless it has paid all the pending dues. We shall not make any investments by way of deposits, loans, share capital, revalue its assets, carry out general trading other than sale of its own products, enter into a arrangement for sale of its products and purchase of raw materials without the prior written approval of the bank. Pursuant to the aforesaid covenants, we have obtained the no objection from the lender for this Issue.



## 6. OBJECTS OF THE ISSUE

The Issue is being made to raise funds for the following purposes:

- **To set up Bio-Diesel Manufacturing Unit**
- **To meet the Additional Working Capital requirement on account of increased operations for the Agrochemical & Bio Fertilizer division**
- **To repay Short Term Loan availed of from Union Bank of India for partially meeting expenses related to Bio diesel plant**
- **To partially repay the working capital loan facility availed from Union Bank of India**
- **To meet the Public Issue Expenses**
- **To achieve the benefits of listing our Company's shares on Bombay Stock Exchange Limited (BSE)**

The main objects of the Memorandum of Association of our Company enable our Company to undertake its existing activities and the activities for which the funds are being raised through this Issue.

### Cost of the Project and Means of Finance

The Cost of the Project and Means of Finance is summarized in the table below:

Sno.	Particulars	Total cost (Rs lakhs)
1	<b>To set up Bio-Diesel manufacturing unit -</b> <b>Total cost</b> <b>Rs 1095.15 Lakhs</b> <b>Less amount already spent</b> <b>Rs 101.76 lakhs</b> <b>Remaining Amount</b> <b>Rs 993.39 lakhs</b>	993.39
2	<b>To meet the additional Working Capital requirement on account of increased operations for the Agrochemical &amp; Bio Fertilizer division</b>	945.00
3	<b>To repay the short term loan limit of Rs 120.00 lakhs availed of from union Bank of Inida for partially meeting the expenses related to setting up of Bio diesel plant and issue expenses</b>	120.00
4	<b>To partially repay the working capital loan facility availed of from Union Bank of India for meeting the working capital requirements of the agro chemical division. At present the company is availing a limit of Rs 430 lakhs from union Bank of India</b>	267.16
5	<b>To meet the public issue expenses</b> <b>Total expenses</b> <b>Rs 159.85</b> <b>Less amount spent</b> <b>Rs 21.40 lakhs</b> <b>Balance amount</b> <b>Rs 138.45 lakhs</b>	138.45
6	<b>To achieve the benefits of listing our Company's shares on Bombay Stock Exchange Limited (BSE)</b>	
	<b>TOTAL</b>	<b>2464.00</b>
	<b>Amount incurred from internal accruals of the company for issue expenses</b>	<b>3.16</b>
	<b>Total</b>	<b>2467.16</b>





### Means of Finance

S.No.	Particulars	(Rs. Lakhs)
1	<b>Equity Funds – ISSUE PROCEEDS</b>	2464.00
	<b>Internal accruals of the company</b>	3.16
	<b>TOTAL</b>	2467.16

Our company is availing of a working capital limit of Rs 430.00 lakhs from union Bank of India for the agrochemical division which meets the total fund requirement of our company other than the proposed IPO proceeds. Thus, we confirm that firm arrangements of finance through verifiable means towards minimum 75% of the stated means of finance, excluding the amount to be raised through proposed Issue, has been ensured.

Any shortfall in the cost of the project would be met out of internal accruals and/or debt. Our Company is dependent on full-subscription to the Public Issue in order to meet its financial requirements for the proposed project.

The fund requirement and deployment are based on internal management estimates and have not been appraised by any bank or financial institution or any independent organization. Our capital expenditure plans are subject to a number of variables, including possible cost overruns; construction/development delays or defects; receipt of critical governmental approvals; availability of working capital finance on acceptable terms; and changes in management's views of the desirability of current plans, among others.

In case of any variations in the actual utilization of funds earmarked for the above activities, increased fund deployment for a particular activity may be met with by surplus funds, if any available in any other project and/or our Company's internal accrual, and/ or the term loans/working capital loans that may be availed from the Banks/ Financial Institutions. No part of the proceeds of this Issue will be paid as consideration to our Promoters, Directors, Key Managerial Employees or companies promoted by our Promoters.

No part of the issue proceeds will be paid as consideration to Promoters, Directors, Key Managerial Personnel, associate or group companies.

Our Company has not bought nor proposes to buy any second hand Machinery from the proceeds of the Issue.

### I. BIO-DIESEL ACTIVITY

#### **COST OF THE PROJECT**

The total project cost of the Bio Diesel unit is estimated to be Rs. 1095.15 lakhs for which Rs 101.76 lakhs has been deployed till August 18,2008 and the remaining amount is Rs. 933.39 lakhs. The details are as under...:

Particulars	Amount (Rs. in Lakhs )	Amount already spent (Rs lakhs)	Balance Amount (Rs lakhs)
<b>Land and Buildings</b>			
Free Hold Land	47.00		15.00
Civil Structures	138.25	26.00	
[ including power utilities ]		185.25	144.25
<b>Plant and Machinery</b>			
Plant and Machinery		542.35	537.35
- Oil Expeller Unit			
- Solvent Extraction Unit			
- Weigh Bridge			
- Storage Tanks			



- Tools and Accessories				
- DG Set and Others				
<b>Deposits and Advances</b>				
Deposits with various Government departments	10.00	10.00		10.00
<b>Pre operative and other expenses</b>				
Computers and Networking	3.00			
Furniture and Interiors	7.40			
- Tankers [ Nos. 3 ]	24.00			
Consultancy ,interest ,travelling and other pre operative expenses	48.15	82.55	55.76	26.79
Working Capital		225.00		225.00
Contingencies @ 5%		50.00		50.00
<b>TOTAL</b>		<b>1095.15</b>	<b>101.76</b>	<b>993.39</b>



## DETAILS OF THE PROJECT COST

The detailed break up of each component of the project cost is as under:-

### 1. Factory land cost and building:

The proposed Bio diesel plant is being set up at Kondapalli near Vijayawada, Andhra Pradesh. Our Company has already purchased freehold land admeasuring 2260.40 sq. yards or 1889.98 Sq.metres with a semi constructed area of 5000 square feet Shed located in plot no. 260A, Kondapalli Industrial Estate, Kondapalli, near Vijayawada from M/s Visakhapatnam Cements Pvt Ltd, having Regd Office at Flat No.107 Kochar Apartments, Begumpet, Hyderabad 500 016 for a sum of Rs 10.00 lakhs. The valuation of the said land has been carried out by an Independent valuer , M/S Jayram Civil Engineering Consultancy, Chartered Engineer, Surveyor and Regd Valuer, on 18.09.2007 and it has been valued at Rs.18,16,000/= vide their Report dated 18.09.2007.

The land development, as per estimate of "Concepts", Architects and Engineers, Vijayawada, dated Dec 04, 2007 will cost Rs 36.60 lakhs. The detailed break up of which is as under..

S.No.	Particulars	Amount (Rs. in lakhs)
1.	Site leveling and filling	18.30*
2.	External flooring	6.14
3.	Construction of compound wall	6.78
4.	Gates	0.88
5.	Land scapping and gardening	4.50
	Total	36.60
	Rounded off	37.00

Our company has incurred an expenditure of Rs 5.00 lakhs for site leveling out of the total estimated amount of Rs 18.30 lakhs

### 2. Buildings and Civil Works :

Buildings and civil works, as per the estimate of 'Concepts', Architects and Engineers, Vijayawada dated August 11, 2008 will cost Rs 138.25 lakhs. The details are as under:

Ground floor	14000 sft	- Rs 96.37 lakhs
First floor	14000 sft	-Rs 41.88 lakhs
Total		Rs 138.25 lakhs

### 3. Plant & Machinery:

We have not placed orders for any Plant and Machinery. We have obtained quotations from different suppliers and cost of plant and Machinery includes impact of taxes and duties. All plant and Machinery would be procured indigenously.

Sr. No.	Description of the machinery	Suppliers	Date of Quotation	Date of delivery /Yet to deliver	Qty.	Total (Rs. Lakhs)
1	De-Huller Machine	D.Muthilingam & Guru Hyderabad	21.08.2007/ Quotation Revalidated on 20.08.2008	Yet to place order	1	12.00
2	Hull seed separator	Do	21.08.2007/ Quotation Revalidated on 20.08.2008	Yet to place order	1	2.50
3	Tractor with trailer & Implements(4.25 x 2 + 1.25 x 2 + 0.18x2)	Navodaya Enterprises, Hyderabad	21.08.2008	Yet to place order	2	11.36



4	Oil Expeller unit for seed crushing (inclu. Double chamber Oil expeller, Electric motors - 50 Hpx 2 nos., oil filter press plate with all accessories)	D.Muthilingam & Guru Venkatesh Engg Works, Hyderabad	21.08.2007/ Quotation Revalidated on 20.08.2008	Yet to place order	1	68.88
5	Solvent Extraction Plant - 25 TPD - cost of all items of the plant assembly	Technochem Engineers Pvt Ltd, Hyderabad	21.08.2007/ Quotation Revalidated on 20.08.2008	Yet to place order	1	327.67
6	Steam Boiler-1.5 tons, Basic Price Rs.14.80 lakhs plus Water pre heater Rs.1.10 lakhs; Dust collector:Rs.1.00 lakhs Plus 3% Packing and forwarding and erection commissioning charges Rs.0.39 lakhs Plus Exc.duty 14.42%+ VAT 4%.	Thermax Ltd., Hyderabad	21.08.2008	Yet to place order	1	21.00
7	125 KVA DG set (Basic price Rs.5.16 lakhs plus Ex.Duty + Sales tax, transportation, Installation charges - Rs. 2.09 lakhs.	Jayalaxmi Generators	20.08.2008	Yet to place order	1	7.25
8	Weighing Bridge 50 tonnes - model SL90 – Rs 4,30,000+VAT 12.5% + erectioncharges Rs11236/	Weitex India Ltd, Hyderabad	21.08.2008	Yet to place order	1	4.95
9	Tools & Accessories	---	---	Toos for Rs 5.00 lakhs have been purchased and for the remaining amount orders are yet to be placed	---	32.74
10	Contingencies @ 10%	---	---	---	---	54.00
					<b>Total</b>	<b>542.35</b>

**4. Pre-operative and other expenses: The pre-operative and other expenses will cost Rs 82.55 lakhs:**

S.No.	Particulars	Rs. in Lakhs
1	Computers and Networking	3.00
2	Furniture and Interiors	7.40
3	Vehicles –Tankers (Nos 3)	24.00
4	Consultancy , Interest during construction period , travelling expenses	48.15
	<b>Total</b>	<b>82.55</b>

**5. Working Capital for Bio Diesel Plant**

As per our internal estimate, the incremental requirement for the working capital would be Rs. 225.00 Lakhs which we plan to finance entirely by the proceeds of this Issue:



(Rs. in Lakhs)

Particulars	2009-10 Projected
<b>Current Assets:</b>	
Inventories	232.88
Cash & Bank Balance	333.53
Debtors	321.36
Other Current Assets	835.54
<b>Total</b>	<b>1723.31</b>
<b>Current Liabilities and Provisions</b>	
Current Liabilities	17.21
Provision for taxation	275.54
<b>Total</b>	<b>292.75</b>
<b>Working Capital Gap</b>	<b>1430.55</b>
<b><u>To be met from:</u></b>	
Working capital funds from Banks	0
Own Funds	1205.55
Part proceeds of IPO	225.00

## II. AGRO CHEMICAL ACTIVITY

### INCREMENTAL WORKING CAPITAL REQUIREMENT

Our anticipated business growth in the agro chemical and bio fertilizer division would push up the working capital requirement on account of the higher inventory levels to be maintained, longer credit period to be offered to our clients, and miscellaneous current assets. As per our internal estimate, the incremental requirement for the working capital would be Rs. 945 lakhs, which we plan to finance entirely by the proceeds of this Issue. With the infusion of the above working capital, our Company proposes to consolidate its existing markets in Andhra Pradesh and propose to expand in the rest of the country. The basis for estimation of working capital is given below:

The requirement of necessary working capital has been worked out as under:

(Rs. in Lakhs)

Particulars	2008-09 Projected
<b>Current Assets:</b>	
Inventories	416.67
Cash & Bank Balance	15
Debtors	1666.67
Advances to suppliers of raw materials	750
Other Current Assets	650
<b>Total</b>	<b>3498.34</b>
<b>Current Liabilities and Provisions</b>	
Creditors	410.96
Provision for taxation	500
<b>Total</b>	<b>910.96</b>
<b>Working Capital Gap</b>	<b>2587.38</b>
<b><u>Financed by:</u></b>	
Working capital funds from Banks	162.84
Own Funds	1479.54*
Part proceeds of IPO	945.00



\* At present our company is availing a working capital limit of Rs 430 lakhs from Union Bank of India. An amount of Rs 267.16 lakhs is proposed to be repaid to Union Bank of India from the issue proceeds reducing the working capital limit from Rs 430 lakhs to Rs 162.84 lakhs

### III. Repayment of short term loan availed from Union Bank of India for meeting the project expenses :

Our Company has incurred an expenditure of Rs. 123.16 lakhs on the proposed Project as on August 18,2008. The fund deployment in the Project and its Means of Finance has been certified by Mr. T. Nehru, Chartered Accountant, Vijayawada, the Auditors of our Company vide their certificate dated August 18,2008. Our company had availed of a short term loan of Rs 120.00 lakhs from Union Bank of India , Vijayawada and the remaining amount of Rs 3.16 lakhs has been spent from the internal accruals of the company . M/S Arun Patibanda, an independent Auditor vide certificate dated February 02,2008 has confirmed that the Bank loan funds have been utilized for expenses related to the project.

Amount Rs. lakhs

Nature of Facility Amount	Sanctioned	Amount Outstanding as on August 25,2008	Bank	Security
Short term Loan	120.00	119.20	Union Bank of India, Main Branch, Vijayawada	Hypothecation of stocks, raw materials, finished goods of pesticides, fungicides and bio- fertilizers & book debts not older than 90 days and personal guarantee of directors

For details of utilisation of funds please refer to deployment of funds in page no. 36.

### IV. Part Repayment of Working capital loan availed from Union Bank of India

Our Company has cash credit facility of Rs.430 lakhs from Union Bank of India. The interest on the regular loan facility of Rs 430.00 lakhs is Bank's BPLR + 0.50% Per annum. Our Company proposes to repay Rs 267.16 lakhs , a part of this loan from the Net Proceeds of the Issue. M/S Arun Patibanda, an independent Auditor vide certificate dated February 02,2008 has confirmed that the Bank loan funds have been utilized for working capital purposes of the agrochemical division of our company.

The details of the loan are as under:

Union Bank of India, Vijayawada Main Branch, vide its letter ref ADV:BM/50168020 of May 23,2007 sanctioned Cash Credit limit as detailed hereunder:

Nature of Facility	Cash Credit(Hyp)
Amount of Limit	Working Capital: (Agro Chemical Division) Rs.430.00 lakhs)
Amount outstanding as on August,25,2008	Rs. 430.00
Margin	CC(Hyp) 25%
Rate of Interest	BPLR Plus 0.5% on regular limit of Rs.430.0 Lakhs
Month of review	May, 2008
Primary Security	1. Hypothecation of stocks of raw material, WIP, Finished goods of pesticides, Fungicides & Bio-fertilisers and Book debts not more than 90 days 2. Hypothecation of movable fixed assets and machineries



Collateral securities	<ol style="list-style-type: none"> <li>1. Three storied Industrial building (two blocks) constructed in an extent of 1849.02 Sq.Yards at R.S.No.183/1, Asst.No3302, Door No.16-130/12, III Cross Road, JRD Tata Industrial Estate, Kanuru, Penamaluru Mandal, Krishna District. In the name of Chemcel Biotech Limited valued Rs. 118.00 lakhs.</li> <li>2. 493.28 Sq.Yds of residential vacant site situated at R.S.No.460, Plot No.28 (Nearest D.No 54-20/4-11), Gurunank colony, Vijayawada in the name of Mr.K.T.Vijaya Kumar, valued Rs.49.39 Lakhs.</li> <li>3. Flat No.101 (plinth area 44.37 sq.yds) at R.S.No.10/8, Sindoor Apts, Gayatri nagar, Vijayawada in the name of Mr.Bala Krishna Rao valued at Rs.14.59 lakhs.</li> <li>4. 393.30 Sq.Yards of residential sites along with RCC framed structure at R.S.No. 43/1(Part), Asst.No.151235, nearest D.No.42-4-121/2; Temple street, Mutyalampadu, Ramakrishnapuram, Vijayawada. In the name of Sri.M.V.R.Sastry, valued Rs.22.39 lakhs.</li> <li>5. 888.88 Sq.Yards of residential vacant site situated at S.No.160, Plot No.70,71,80 and 81 at Kapra, near Hyderabad, Kesara Mandal, R.R District, owned by Sri.K.T.Vijaya Kumar, valued Rs.19.56 lakhs.</li> </ol>
<b>Personal Guarantee</b>	Personal guarantee of all the Directors in their individual capacity and Mr. M. V. R. Sastry.

#### V. ISSUE MANAGEMENT EXPENSES

The expenses for this issue includes underwriting and management fees, selling commission, distribution expenses, legal fees, fees to advisors, stationary costs, advertising expenses and listing fees payable to the Stock Exchanges among others. The total expenses for this Issue are estimated at Rs. 159.85 lakhs being, which will be paid by our Company:

Particulars	Total cost (Rs. in Lakhs)	Amount already spent	Balance amount
Brokerage	23.90		23.90
Lead Manager, registrar , Legal fee ,SEBI fee ,BSE fee	30.55	13.15	17.40
Advertisement	20.00		20.00
Printing of Application, Prospectus & Brochures	31.50		31.50
Grading agency	2.25	2.25	-
Postage – Registered	8.00	-	8.00
Conferences	9.00		9.00
Connectivity Charges to BSE	1.00		1.00
Deposit to BSE	19.00		19.00
Travelling, conveyance and other expenses	14.65	6.00	7.80
<b>TOTAL</b>	<b>159.85</b>	<b>21.40</b>	<b>138.45</b>

#### Schedule of implementation Bio Diesel Project:

Factory land with shed	September 07
Commencement of installation of Plant and Machinery	<b>December 08</b>
Completion of the installation	<b>June 09</b>
Commencement of trial production	<b>July 09</b>
Procurement of seed for commercial production	<b>August 09</b>
Commencement of commercial production	<b>September 09</b>

**Deployment of Funds**

Our Company has incurred an expenditure of Rs. **123.16** lakhs on the proposed Project as on August 18, 2008. The fund deployment in the Project and its Means of Finance has been certified by Mr. T. Nehru, Chartered Accountant, Vijayawada, the Auditors of our Company vide their certificate dated August 18, 2008 and the details of the same are as follows:-

(Rs. In Lakhs)

Particulars	Total Project Cost	Expenses incurred till Aug 18, 2008
Free Hold Land	47.00	15.00
Civil Structures	138.25	26.00
Plant and Machinery	542.35	5.00
Deposits and Advances	10.00	
Issue Expenses	159.85	21.40
Preoperative Expenses	82.55	55.76
Working Capital	1170.00	
Contingencies	50.00	
Partial repayment of working capital loan	267.16	
<b>Total</b>	<b>2467.16*</b>	<b>123.16</b>

\* The proceeds from the proposed issue are Rs 2464 lakhs and Rs 3.16 lakhs has been spent from the company's internal accruals

**Source of Financing of Funds already deployed**

Particulars	(Rs. In Lakhs)
Adhoc loan from Union Bank of India	120.00
Internal Accruals	3.16
<b>Total</b>	<b>123.16</b>

**Schedule of Expenses To Be Incurred Against the Project Cost**

(Rs. in Lakhs)

Particulars	Total Project Cost	Expenses incurred till Aug 18 2008	Remaining Expenses to be incurred						
			Sept,08	Oct-Dec-08	Jan.09-Mar09	9-Jul	Aug,2009	Total	
Free Hold Land	47.00	15.00		32.00					<b>32.00</b>
Civil Structures	138.25	26.00		112.25					112.25
Plant and Machinery	542.35	5.00		537.35					537.35
Deposits and Advances	10.00		10.00						10.00
Issue Expenses	159.85	21.40	138.45						138.45
Preoperative Expenses	82.55	55.76	26.79						26.79
Working Capital- Agrochemicals	945.00			500.00	445.00				945.00





Working Capital-Biodiesel	225.00					100.00	125.00	225.00
Contingencies	50.00		30.00	20.00				50.00
Repayment of Bank Loan	267.16	267.16						267.16
<b>Total</b>	<b>2467.16</b>	<b>123.16</b>	<b>442.40</b>	<b>1211.60</b>	<b>465.00</b>	<b>100.00</b>	<b>125.00</b>	<b>2344.00</b>

### MONITORING AGENCY

In terms of Clause 8.17 of the SEBI DIP Guidelines, 2000, there is no requirement of Monitoring Agency. Our Company has set up Audit Committee comprising of non executive and independent directors who have been entrusted with the responsibility of monitoring the use of issue proceeds. Our Company will disclose with utilization of the proceeds of the issue under a separate head a separate head in the Balance Sheet clearly specifying the purpose for which such proceeds have utilized. It shall also, in its Balance Sheet, provide details, if any, in relation to all such proceeds have not been utilized thereby also indicating investment if any, such unutilized proceeds of the issue.

### INTERIM USE OF FUNDS

Pending utilization of the proceeds out of the Issue for the purposes described above, our Company intends to temporarily invest the funds in high quality interest/dividend bearing short Term/long-term liquid instruments including money market mutual funds, deposits with Banks, for the necessary duration, gilt edged securities and other 'AAA+' rated interest bearing securities as may be approved by our Board or a duly authorized committee thereof.



## 7. BASIC TERMS OF THE ISSUE

### Terms of the Issue

The Equity Shares being issued are subject to the provisions of the Companies Act 1956, the Memorandum and Articles, FIPB and RBI approvals, the terms of this Prospectus and other terms and conditions as may be incorporated in the allotment advices and other documents/certificates that may be executed in respect of the Issue. The Equity Shares shall also be subject to laws, guidelines, notifications and regulations relating to the issue of capital and listing and trading of securities issued from time to time by SEBI, Government of India, Stock Exchanges, RBI, Registrar of Companies and/or other authorities, as in force on the date of the Issue and to the extent applicable.

### Authority for the Issue

The present issue has been authorized by a special resolution adopted pursuant to Section 81(1A) of the Companies Act, at the Extraordinary General Meeting of the shareholders of our Company held on August 14, 2008

### Ranking of Equity Shares

The Equity Shares being issued shall be subject to the provisions of the Memorandum and Articles and shall rank pari- passu with the existing Equity Shares of our Company in all respects except the lock-in provisions applicable as per SEBI DIP Guidelines in respect of existing Equity Shares. The allottees of the Equity Shares under this Issue will be entitled to dividends and other corporate benefits, if any, declared by our Company after the date of allotment.

### Face Value and Issue Price

The Equity Shares with a face value of Rs.10/- each are being offered in the Issue at a price of Rs.16/- per equity share which is 1.6 times of the face value. At any given point of time there shall be only one denomination for the Equity Shares subject to applicable laws.

### Terms of Payment:

The Applications should be for minimum of 350 Equity Shares and in multiples of 350 Equity Shares thereafter. Entire amount is payable on application.

The amount payable is as under:

Particulars	Amount towards Share Capital	Amount towards Share Premium	Amount Payable
On application	Rs.10/-	Rs. 6/-	Rs.16/-

Where an applicant is allotted lesser number of Equity Shares than he / she has applied for, the excess amount paid on application will be refunded to the applicant.

No interest would be payable on application money pending allotment up to 30 days from the date of closure of the Issue.

### Rights of the Equity Shareholder

Subject to applicable laws, the equity shareholders shall have the following rights:

- Right to receive dividend, if declared;
- Right to Receive Notices, attend general meetings and exercise voting powers, unless prohibited by law;
- Right to vote on a poll either in person or by proxy;
- Right to receive offers for rights shares and be allotted bonus shares, if announced;
- Right to receive surplus on liquidation;
- Right of free transferability; and
- Such other rights, as may be available to a shareholder of a listed public Company under the Companies Act and our Company's Memorandum and Articles.



For a detailed description of the main provisions of our Articles relating to voting rights, dividend, forfeiture and lien and/or consolidation/splitting, refer to the section on “Main Provisions of Articles of Association of our Company “ on page no.189 of this Prospectus.

### **Market Lot**

In terms of Section 68B of the Companies Act, the Equity Shares in this Issue shall be allotted only in dematerialized form. As per existing SEBI DIP Guidelines, the trading of the Equity Shares shall only be in dematerialized form. Since trading of the Equity Shares is in dematerialized form, the tradable lot is one Equity Share.

### **Minimum Subscription**

If our Company does not receive the minimum subscription of 90% of the net offer to public on the date of closure of the Issue, or if the subscription level falls below 90% after the closure of Issue on account of cheques having being returned unpaid or withdrawal of applications, our Company shall forthwith refund the entire subscription amount received. If there is a delay beyond 8 days after our Company becomes liable to pay the amount, our Company shall pay interest as per Section 73 of the Companies Act, 1956. No statement made in this offer document shall contravene any of the provisions of the Companies Act, 1956.

### **Period of Subscription**

The subscription list for public issue shall remain open for at least 3 working days and not more than 10 working days.

### **Reservations**

<b>16,00,000</b>	<b>Equity shares of Rs 10 each reserved for promoters at a price of Rs.16/- per share</b>
<b>10,00,000</b>	<b>Equity shares of Rs 10 each reserved for eligible employees and directors on competitive basis at a price of Rs.16/- per share</b>
<b>64,00,000</b>	<b>Equity shares of Rs 10 each reserved for Retail Investors on competitive basis at a price of Rs.16/- per share</b>



## 8. BASIS FOR ISSUE PRICE

The issue price of Rs.16/- (including premium of Rs.6/- per share) has been determined by our Company in consultation with the Lead Manager to the Issue. The face value is Rs.10/- per equity share. The issue price is 1.6 times of the face value.

Investors should read the following summary along with the Risk Factors included in this Prospectus from page no. xii and the details of the Issuer Company and its financial statements included in this Prospectus. The trading price of the Equity Shares of our Company could decline due to these risks and the investor may lose all or part of his investment.

### Qualitative Factors

#### Distribution Strengths:

Our distribution network consists of distributors and dealers through out the coastal region of Andhra Pradesh. Our Company has more than 18 distributors who help us in selling our products to end users through the chain of more than 350 dealers and 550 retailers. We hold regular farmers meets at different places to educate and disseminate new methods of the plant protection with the help of our techno commercial marketing sales staff, dealers and distributors. With the help our distribution network & marketing team, we keep ourselves updated about the occurrence of a particular pest. Based on this information and our experience, we reschedule our production and distribution. We have established 24 depots wherein we maintain adequate stocks to make our products available at short notices. This strategy helps us in selling our products effectively.

#### Our Product Range:

We have 34 products in our product portfolio which consists of different kind of insecticides and pesticides. We manufacture various formulations comprising of liquids, granules and powder formulations. Our products are available in various sizes of packaging catering to the needs of small, marginal and large farmers. Our product range covers most of the crops and majority of plant infections that are grown in this region. We provide end to end plant protection solutions to farmers through our distributors. Our product range helps us in attracting large distributors of agrochemicals to become our distributors.

#### Our Team and Management:

Our Chairman Mr. Kanuparthi Balakrishna Rao, who has more than 40 years of experience in this Industry, has been instrumental in guiding the board in formulation of strategy and planning. Our managing director Mr. K.T. Vijaya Kumar with more than 30 years experience in this industry has overall control over day to day activities of our Company and has been able to motivate our key managerial personnel to create a team of dedicated techno commercial marketing staff, dealers and distributors.

#### Existing profit making company

#### Huge potential in the bio-diesel industry and support of the Government to promote the industry

#### Quantitative factors:

Information presented in this section is derived from our Company's restated financial statements prepared in accordance with Indian GAAP. Some of the quantitative factors, which form the basis for computing the price, are as follows

#### 1. Earnings Per Share

Accounting year ending	Stand alone		Consolidated	
	EPS (Rs.)	Weights	EPS (Rs.)	Weights
31 <sup>st</sup> March 2006	1.14	1	-	-
31 <sup>st</sup> March 2007	0.89	2	-	-
31 <sup>st</sup> March 2008	1.17	3	<b>1.16</b>	
Weighted average	1.09		<b>1.16</b>	



## 2. Price Earnings ratio (P/E Ratio) in relation to Issue price of Rs.16/- per share

Particulars	Issue price of Rs.16/- per share	
	Stand alone	Consolidated
Based on 31 <sup>st</sup> March 2008 EPS	13.68	13.79
Based on Weighted average EPS	14.68	14.78

Industry P/E (Pesticides /agrochemicals – Indian)

- i. Highest - (United Phosphorous) - 63.30
- ii. Lowest (Insecticides) - 4.00
- iii. Industry Average - 25.80 (Average of Highest & Lowest)

Source: Capital Markets Volume XXIII/13 August 25- September 07, 2008

## 3. Return on Networth (RONW)

Accounting year ending	Stand alone		Consolidated	
	RONW (%)	Weight	RONW (%)	Weight
31 <sup>st</sup> March 2006	10.69	1	-	-
31 <sup>st</sup> March 2007	7.75	2	-	-
31 <sup>st</sup> March 2008	9.24	3	9.14	-
<b>Weighted Average</b>	<b>8.99</b>		9.14	-

Minimum return on Total Net worth needed to maintain EPS (as on March 31, 2008) at Rs.1.17 is **7.99%**

## 4. Net Asset Value per share

	STAND ALONE	CONSOLIDATED
As at March 31, 2008	Rs. 12.64	12.63
After Issue	<b>Rs 14.64</b>	<b>14.63</b>
Issue Price	<b>Rs 16.00</b>	<b>16.00</b>

## 5. Accounting Ratios of some of the companies in the same industry group (Based on the Annual statements for the year ended Mar 31, 2008)

### i. Pesticides/Agrochemicals – Indian

	Sales (Rs lakhs)	Face value per share	Book value (Rs.)	Net profit (Rs. lakhs)	EPS (Rs.)	P/E	RONW (%)
P I Inds	37090	Rs 10	192.7	630	17.80	8.60	7.4
Bharat Rasayan	6900	Rs 10	68.8	400	9.40	5.00	3.0
Insecticides (India) Limited	187.40	Rs 10	65.40	1440	11.10	4.00	24.4
Paushak	2190	Rs 10	67.00	70	2.30	10.30	3.70
Bhagiratha Chemicals	8170	Rs 10	71.10	650	12.40	4.00	19.40
<b>Chemcel Biotech Limited</b>	<b>2462</b>	Rs 10	<b>12.64</b>	<b>123</b>	<b>1.17</b>	<b>13.68</b>	<b>9.24</b>

Source: Capital Markets Volume XXIII/13 August 25- September 07, 2008.

### ii. Proposed Bio diesel Activity :

Our Company cannot be strictly compared with other listed companies, as no listed company is exclusively into the production of Bio diesel.



The face value of the share is Rs.10/- and the issue price is **1.6** times of the face value.

The Lead Manager believes that the Issue Price of Rs.**16/-** is justified in view of the above qualitative and quantitative parameters. The investors may want to peruse the risk factors and financials of our Company including important profitability and return ratios, as set out in the Auditor's report to have a more informed view of the investment proposition.



## 9. STATEMENT OF TAX BENEFITS

### TAX BENEFITS TO THE COMPANY AND ITS MEMBERS

I, **T.Nehru**, Chartered Accountant, being the Auditor of the Company, hereby state that under the current provisions of the Income Tax Act, 1961 and the existing laws for the time being in force, the following benefits, inter-alia, will be available to the Company and the Members.

#### General Tax Benefits

**The following tax benefits are available to all companies or to the shareholders of any company, after fulfilling certain conditions as required in the respective Act.**

#### A. To the Company

The Company will be entitled for the following tax benefits in computing the Taxable Income under the Provisions of the Income Tax Act, 1961 (The Act).

1. Under Section 32 of the Income Tax Act, the Company is entitled to claim depreciation on tangible and intangible assets as well as unabsorbed depreciation brought forward as explained in the said section.
2. The company is eligible for amortization of preliminary expenses being the expenditure on public issue of shares under Section 35D of the Income Tax Act, subject to the conditions and limits specified in the Section.
3. Dividends received by the Company from other domestic companies are exempt in the hands of Company as per the provisions of Section 10(34) of the Income Tax Act.
4. 4.1 In accordance with the provisions of Section 10 (38), the long term capital gains arising on the transfer of securities in a transaction entered into a recognized stock exchange in India shall be exempt from Income Tax.  
4.2 The long term capital gains accruing to the Company otherwise than as mentioned in 4.1 above, shall be chargeable to tax in accordance with and subject to the provisions of Section 112 of the Income Tax Act, 1961 as follows:
5. The short term capital gains accruing to the company, from the transfer of a short term capital asset, being securities, in a transaction entered in a recognized stock exchange in India, shall be chargeable to tax at the rate of 15% (plus applicable surcharge and education cess) as per the provisions of Section 111A.
6. The Company is eligible to claim exemption in respect of tax on long term capital gains u/s 54EC & 54ED if the amount of capital gains is invested in certain specified bonds/securities subject to the fulfillment of the conditions specified in those sections.

#### B. To the resident shareholders

##### 1. Dividends exempt under Section 10(34)

Dividends (whether interim or final) declared, distributed or paid by the Company are exempt in the hands of shareholders as per the provisions of Section 10(34) of the Income Tax Act.

##### 2. Computation of capital gains

- i. Capital assets may be categorized into short term capital assets and long term capital assets based on the period of holding. All capital assets (except shares held in a Company or any other listed securities or units of UTI or specified Mutual Fund units) are considered to be long-term capital assets if they are held for a period in excess of 36 months. Shares held in a Company, any other listed securities, units of UTI and specified Mutual Fund units are considered as long term capital assets if these are held for a period exceeding 12 months. Consequently, capital gains arising on sale of Shares held in a Company or any other listed securities or units of UTI or specified Mutual Fund units held for more than 12 months are considered as "long term capital gains".



- ii. Section 48 of the Income Tax Act, which prescribes the mode of computation of capital gains, provides for deduction of cost of acquisition / improvement and expenses incurred in connection with the transfer of a capital asset, from the sale consideration to arrive at the amount of capital gains. However, in respect of long term capital gains, it offers a benefit by permitting substitution of cost of acquisition / improvement with the indexed cost of acquisition / improvement, which adjusts the cost of acquisition / improvement by a cost inflation index as prescribed from time to time.

Under section 10(38) of the Income Tax Act, long term capital gains arising on sale of equity shares or units of an equity oriented fund, where the transaction of sale is entered into on a recognized Stock Exchange in India, on or after 1st October, 2004 and is chargeable to securities transaction tax, shall be exempt from tax.

Under Section 88E, rebate in respect of securities transaction tax will be admissible from the amount of income tax payable in respect of income from business or profession subject to the conditions specified therein.

- iii. Under section 54EC of the Income Tax Act and subject to the conditions and to the extent specified therein, long term capital gains arising on the transfer of shares of the Company that are not exempt under section 10(38) of the Income Tax Act, shall not be chargeable to tax if the whole or any part of the capital gains is invested in certain notified bonds within a period of six months after the date of such transfer. However if the said bonds are transferred or converted into money within three years from the date of their acquisition, the amount of capital gains exempted earlier would become chargeable to tax as long-term capital gains in the year in which the bonds are transferred or converted into money.
- iv. Under section 54ED of the Income Tax Act and subject to the conditions and to the extent specified therein, long term capital gains arising on the transfer of shares of the Company that are not exempt under section 10(38) of the Income Tax Act, shall not be chargeable to tax if the whole or any part of the capital gains is invested in acquiring equity shares of Indian Company forming part of an "eligible issue of share capital" within a period of six months after the date of such transfer. However if the said shares are transferred within a period of one year from the date of their acquisition, the amount of capital gains exempted earlier would become chargeable to tax as long term capital gains in the year in which the shares are transferred. Eligible issue of share capital has been defined as an issue of equity shares which satisfies the following conditions:
- ★ The issue is made by a public company formed and registered in India; and
  - ★ the shares forming part of the issue are offered for subscription to the public.
- v. Under section 54F of the Income Tax Act, long term capital gains arising to an individual or Hindu Undivided Family (HUF) on transfer of shares of the company, will be exempt from tax subject to other conditions specified therein, if the sale proceeds from such shares are used for the purpose of purchase of residential house property within a period of one year before and two years after the date on which the transfer took place or for construction of residential house property within a period of three years after the date of transfer.
- vi. Under section 111A of the Income Tax Act, short term capital gains arising on sale of shares where the transaction of sale is entered into on a recognized stock exchange in India and is chargeable to securities transaction tax, on or after 1st October 2004 shall be subject to tax at a rate of 15% (plus applicable surcharge and education cess).
- vii. Under section 112 and other relevant provisions of the Income Tax Act, long term capital gains arising on transfer of shares of the company not covered by section 10(38) of the Income Tax Act, shall be subject to tax at a rate of 20% (plus applicable surcharge and education cess) after indexation as provided in the second proviso to section 48 or at 10% (plus applicable surcharge and education cess) without indexation, at the option of the shareholder. However, as per the proviso to section 112(1) of the Income Tax Act, if the tax on long term capital gains





resulting on transfer of listed securities or units, calculated at the rate of 20% with indexation benefit exceeds the tax on long term capital gains computed at the rate of 10% without indexation benefit, then such gains are chargeable to tax at a concessional rate of 10% (plus applicable surcharge and education cess).

- viii. Under Section 115AD of the Income Tax Act, income received by Foreign Institutional Investor in respect of securities shall be taxed @ 20%. Income by way of Long Term Capital Gains arising from the transfer of such securities shall be taxed @ 15%. With effect from A. Y. 2005-06, Income by way of Short Term Capital Gains referred to in section 111A arising from the transfer of such securities shall be taxed @ 10%.

### **C. Additional Benefits Available to non-resident Indians**

Non-resident Indians have an option to be governed by the special provisions of Chapter XIA of the Income Tax Act according to which:

- i Under Section 115 E of the Income Tax Act, where the total income of non-residents Indian includes income by way of long term capital gains on equity shares of Indian company, long term capital gains will be taxed @ 10%.
- ii Under Section 115 F of the Income Tax Act, where there is a long term capital gain on transfer of foreign exchange assets and within a period of six months after the date of such transfer net consideration is invested in equity share or saving certificates as specified in clause (4B) of Section 10 the capital gain will be nil. But if the new assets so acquired is transferred or converted in money within a period of three years from the date of acquisition the amount of capital gain not so charged will be deemed to be the income under the head Capital Gains in the year in which such asset is transferred or converted into money.
- iii Under Section 115 G of the Income Tax Act, it shall not be necessary for the Non-resident Indians to furnish their return of Income, under section 139(1) of the Act, if their source of income is only investment income or income by way of long term capital gains or both, provided income tax deductible at source under the provisions of chapter XVII B has been deducted from such income.
- iv The benefit conferred on a Non-resident Indian assessee will be available even after the assessee becomes a resident if declaration in writing is filed along with the return of income under Section 139(1) of the Income Tax Act, to the effect that the provisions of Chapter XII A shall continue to apply to him in respect of investment income derived from foreign exchange asset vide Section 115 H of the Income Tax Act, until the Transfer or conversion (otherwise than by transfer) into money of such assets.
- v Under Section 115-I of the Income Tax Act, a Non-resident Indian, if he elects by so declaring in the return of his income for that assessment year, not to be governed by the above mentioned special provisions of chapter XII-A, then he will be entitled to tax benefits available to resident individuals.
- vi Shareholders who are tax residents of countries with which India has entered into Double Tax Avoidance Agreements ("DTAA") may choose to pay tax in accordance with such applicable DTAA, instead of the tax regime discussed above, if the same is considered beneficial by them.

### **D. Benefits available to Mutual Funds**

Under section 10(23D) of the Income Tax Act, all Mutual Funds set up by Public Sector Banks or Public Financial Institutions or Mutual Funds registered under the Securities and Exchange Board of India or authorized by the Reserve Bank of India, subject to the conditions specified therein are eligible for exemption from income-tax on all their income, including income from investment in the equity shares of a company.

### **E. Benefits available to Venture Capital Companies / Funds**

Under section 10(23FB) of the Income Tax Act, all venture capital companies / funds registered with the Securities and Exchange Board of India, subject to the conditions specified, are eligible for exemption from income-tax on all their income, including income from investment in the equity shares of a company.



**F. Benefits available to resident shareholders under the Wealth Tax Act, 1957**

Shares of the Company held by the shareholders will not be treated as an asset within the meaning of section 2(ea) of the Wealth Tax Act, 1957 and hence Wealth Tax will not be applicable.

**G. Finance Act, 2008**

The amendments made under Finance Act, 2008 have also been considered.

**Special Tax Benefit :**

**H. Central Excise exemption available on Biodiesel**

Excise duty on bio-diesel (alkyl esters of long chain fatty acid from vegetable oils falling under Chapters 29 or 38) has been fully exempted. (S.No. 53A of the Notification No. 4/2006-Central Excise as inserted vide Notification No. 4/2007-Central Excise refers)

Place: VIJAYAWADA

Date : 12.07.2008



## SECTION IV: ABOUT OUR COMPANY

*Disclaimer: Pursuant to the requirements of the SEBI DIP Guidelines, the discussion on the business of Our Company in this Prospectus consists of disclosures pertaining to industry grouping and classification. The industry grouping and classification is based on Our Company's own understanding and perception and such understanding and perception could be substantially different or at variance from the views and understanding of third parties. Our Company acknowledges that certain products described in the Prospectus could be trademarks, brand names and/or generic names of products owned by third parties and the reference to such trademarks, brand names and/or generic names in the Prospectus is only for the purpose of describing the products. The industry data has been collated from various industry and/or research publications and from information available from the World Wide Web.*

*The information in this section is derived from various government/Industry Association publications, CRISIL research reports, ICRA research Reports and other sources. Neither we, nor any other person connected with the issue has verified this information. Industry sources and publications generally state that the information contained therein has been obtained from sources generally believed to be reliable, but their accuracy, completeness and underlying assumptions are not guaranteed and their reliability cannot be assured and accordingly, investment decisions should not be based on such information.*

### INDUSTRY OVERVIEW

Source; **CRISIL RESEARCH- RENEWABLE ENERGY SOURCES – ANNUAL REVIEW – July 2008**

#### **Bio-Diesel Industry**

In 2007-08, total petroleum product consumption stood at an estimated 128.23 million tonnes. Petrol (10.67 million tonnes) and diesel (47.8 million tonnes) jointly accounted for around 48 per cent of this consumption.

Petrol consumption rose at a CAGR of 7.11 per cent from 2002-03 to 2007-08 and is expected to grow at CAGR of 7.8 per cent over next 5 years. Similarly, diesel consumption, which grew at a CAGR of 5.5 per cent from 2002-03 to 2007-08, is expected to grow at 7.0 per cent from 2007-08 to 2012-13. Crude oil imports at \$68 billion accounted for 28 per cent of total imports in 2007-08. The blending of diesel and petrol with biofuels will result in marginal reduction in crude oil imports.

#### **Introduction**

Biodiesel (mono alkyl esters) is a biodegradable, clean-burning diesel fuel made from natural, renewable sources such as new vegetable oils, used (waste) vegetable oils (yellow grease) and animal fats. Biodiesel contains no sulphur or aromatics and is oxygenated, which provides additional environmental benefits as compared with standard diesel fuel. Biodiesel is widely available in both neat form (B100) and in blends with petroleum diesel (B2, B5, and B20). It can act as a diesel substitute, requires very little or no engine modifications up to 20 per cent blend and needs only minor modifications for a higher percentage blend. In India, potential commodity sources for biodiesel are non-edible oils obtained from plant species such as *Jatropha Curcas* (Ratanjot), *Pongamia Pinnata* (Karanj), *Calophyllum inophyllum* (Nagchampa), *Hevca brasiliensis* (Rubber) etc. Bio Diesel is a renewable domestically produced liquid fuel that can help reduce the countries dependence on foreign oil imports. Recent environmental and economic concerns (Kyoto Protocol) have prompted resurgence in the use of biodiesel throughout the world. In 1991, the European Community, (EC) Proposed a 90% tax reduction for the use of biofuels, including biodiesel. Today, 21 countries worldwide, produce Biodiesel.

#### **The Advantages of Bio Diesel**

- ◆ Bio Diesel is the most valuable form of renewable energy that can be used directly in any existing, unmodified diesel engine.
- ◆ **Energy Independence:** Considering that oil priced at \$60 per barrel has had a disproportionate impact on the poorest countries, 38 of which are net importers and 25 of Which import all of their oil; the question of trying to achieve greater energy independence one day through the development of biofuels has become one of 'when' rather than 'if,' and, now on a near daily basis, a biofuels programme is being launched somewhere in the developing world.
- ◆ **Smaller Trade Deficit:** Rather than importing other countries' ancient natural resources, we could be using our own living resources to power our development and enhance our economies. Instead of looking



to the Mideast for oil, the world could look to the tropics for biofuels. producing more biofuels will save foreign exchange and reduce energy expenditures and allow developing countries to put more of their resources into health, education and other services for their neediest citizens.

- ♦ **Economic Growth:** Biofuels create new markets for agricultural products and stimulate rural development because biofuels are generated from crops; they hold enormous potential for farmers. In the near future—especially for the two-thirds of the people in the developing world who derive their incomes from agriculture.
- ♦ Today, many of these farmers are too small to compete in the global market, especially with the playing field tilted against them through trade distorting agricultural subsidies. They are mostly subsistence farmers who, in a good year, produce enough to feed their families, and in a bad year, grow even poorer or starve. But biofuels have enormous potential to change this situation for the better.
- ♦ At the community level, farmers that produce dedicated energy crops can grow their incomes and grow their own supply of affordable and reliable energy.

At the national level, producing more biofuels will generate new industries, new technologies, new jobs and new markets.

- ♦ **Cleaner Air:** Biofuels burn more cleanly than gasoline and diesel. Using biofuels means producing fewer emissions of carbon monoxide, particulates, and toxic chemicals that cause smog, aggravate respiratory and heart disease, and contribute to thousands of premature deaths each year.
- ♦ **Less Global Warming:** Biofuels contain carbon that was taken out of the atmosphere by plants and trees as they grew. The Fossil fuels are adding huge amounts of stored carbon dioxide (CO<sub>2</sub>) to the atmosphere, where it traps the Earth's heat like a heavy blanket and causes the world to warm. Studies show that biodiesel reduces CO<sub>2</sub> emissions to a considerable extent and in some cases all most nearly to zero.

(Source; Report of the committee on development of bio fuel- Planning commission , Govt of India )

#### Bio-diesel . Physical properties

Standard / Specification	Unit	Value
Boiling Point	C	190-340
Melting Point	C	-40 to -10
Density	G/cm <sup>3</sup>	0.87-0.90
Viscosity	Nm <sup>2</sup> /s	3.5-5.0
Flash point	C	165
Cetane number		48-65
Acid number	mg KOH/g	<0.8
Vapour Pressure	Psi	0.2
Appearance		Appearance Pale Yellow Liquid
Odour		Odour Mild Odour
Specific heat	Btu/lb °F	0.48
Latent Heat of Vapourisation	Btu/gal @ 60° F	700
Auto ignition temperature	Deg C	320
Solubility in Water		Negligible



**Source: Planning commission**

**Properties of different methyl esters in comparison with diesel fuel**

Fuel Property	Soybean Methyl Ester	Rapeseed Methyl Ester	No. 2 Diesel Fuel
Formula	C18 to C19	C18 to C19	C8 to C25
Carbon (% wt)	78	81	84-87
Hydrogen (% wt)	11	12	13-16
Oxygen	11	7	0
Specific gravity	0.87	0.88	0.81
Pour point (° C)	-3	-15	-23
mPa-s at 20° C	3.6	3.6	2.6 – 4.1
Lower Heating Value kJ/L	32	37	35-37
Flash Point (° C)	–	179	74
Cetane Number	52	62	40 – 55

**Source: Planning Commission report**

**Global scenario**

Global biodiesel production is driven by the different feedstock in the region. In Europe, sunflower and rapeseed are the main sources, while soybean is used in the USA.

**Feedstock used for bio-diesel production**

Country /Region	Raw material
Europe	Sunflower, Rapeseed
USA	Soybean
Thailand	Palm oil
Ireland	Frying oil and Animal fats

**Source: Planning Commission**

Global biodiesel production has been estimated to be 5.16 million tonnes in 2006, up 64 per cent from 3.16 million tonnes in 2005. The prevailing high crude oil prices and the government's eco-friendly policies have aided this high growth in production. Germany has been the leading manufacturer, accounting for 51 per cent of the global production in 2006. France is also an important player, followed by the United States. Southeast Asia (Malaysia, Indonesia, Singapore, and China), Latin America (Argentina and Brazil), and Southeast Europe (Romania and Serbia) has also seen a rise in biodiesel production.



## Global bio-diesel production

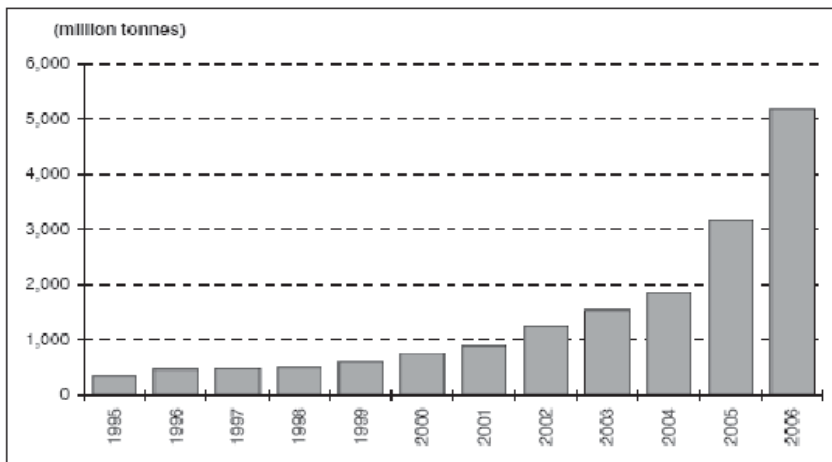

**Source: Earth policy institute**

Malaysia, being the leading manufacturer of palm oil, is likely to account for 10 per cent of the global biodiesel market by 2010 based on its palm oil plantations. Indonesia also has planned to expand its palm oil plantations by 1.5 million hectares by 2008 to reach a total of 7 million hectares. The biofuels expansion program also includes \$100 million in subsidies for palm oil and other agro-fuels such as soybean and maize.

### ***Environmental and other issues***

The results of various tests indicate substantial reduction in smoke density, gaseous pollutants and aromatic hydrocarbons due to usage of biodiesel. However, emissions of nitrogen oxide rise slightly depending on the duty cycle and testing methods.

Also, as biodiesel has a much higher flash point, it is least likely to produce explosive air/fuel vapours. Therefore, it is safer to handle and store than diesel. Furthermore, biodiesel's superiority over diesel is reinforced by its biodegradability and non-toxic nature. The fuel can degrade within 30 days, and thus, creates lesser problems in case of accidental release or spillage.

If burned without additives, Biodiesel (B100) is estimated to produce about 10 per cent more nitrogen oxide emissions than diesel; however, these emissions can be reduced through the use of catalytic converters.

The success of biodiesel programme depends on the sustained plantation and availability of jatropha seeds. This calls for the involvement of farmers, local governing bodies and self-help groups to increase the plantation of jatropha crop. The policies have not addressed the mechanism of providing finance during the initial 3 years as the jatropha crop start bearing seeds only from the third year. This is likely to cause a delay in implementation of the blending norm.

The National Mission on Biodiesel aimed at 5 per cent blending by 2006-07 and 20 per cent blending by 2011-12. The start of the National mission envisaged a pilot programme of plantation of jatropha over 0.4 million hectares, followed by self-sustaining cultivation programme in second phase. The Ministry of Rural Development was set up as the nodal agency with focus on large-scale cultivation of jatropha. However, the programme was finalised only in October 2006.

The Ministry of Petroleum And Natural Gas announced the biodiesel purchase policy in October 2005. The policy, which laid down the pricing and collection mechanism, directed the oil marketing companies to purchase biodiesel which met the BIS standards at Rs 25 per litre. The policy required registered biodiesel manufacturers to deliver B100 (100 per cent biodiesel) at the notified purchase centres inclusive of taxes and duties and transportation costs for the delivery of biodiesel at the purchase centres. The policy also outlined setting up 20 purchase centres by OMCs all over the country. The National bio-fuel policy has been drafted and has been submitted to the cabinet committee in February 2008 for approval. The policy aims at setting up the National biofuel board which will act as apex board to implement the policies and monitor the use of biofuels on regular basis. The policy is likely to be delayed as the global rise in prices of agricultural crops is being linked to use of available stock for production of biofuels.



The biodiesel requirement at 5 per cent blending norm is expected to be 3.12 million tonnes in 2011-12. In order to meet this demand an estimated plantation of 2.3 million hectares needs to be planted. However, not more than 0.5 million hectares are estimated to have been planted till 2007. Since some of these plantations were done 2 years back, they are mostly from the experimental phase, and the actual output and yield per plant will be known only when the initial output is available.

### Diesel consumption and forecast

#### Area Coverage vs. Blending Requirements

Year	Diesel Demand MMT	Bio-Diesel @5% MMT	Area for 5% Mha	Bio-Diesel @10% MMT	Area for 10% Mha	Bio-Diesel @20% MMT	Area for 20% Mha
2005-06	49.56	2.48	2.07	4.96	4.14	9.91	8.28
2006-07	52.33	2.62	2.19	5.23	4.38	10.47	8.76
2011-12	66.90	3.35	2.79	6.69	5.58	13.38	11.19

(Source: [www.ibef.org](http://www.ibef.org) website accessed on August 11, 2008 )

#### Inadequate plantation will impact ability to provide sustained supply

The supply of biodiesel is contingent upon the Jatropha plantation programme undertaken. A considerable portion of the programme has been made part of initiatives of rural employment scheme and forest management programmes. However, the linkage of output of seeds from the plantation has not been given due importance. As a result, the progress of these schemes is expected to be slow. The jatropha plantation after accounting for the initiatives by various states and private players is estimated to be less than 0.5 million hectares in 2007-08.

A large scale plantation of jatropha is imperative, as it can ensure sustained availability of biodiesel. Though the land for cultivation of jatropha has been identified, large scale plantation would require the involvement of farmers, self help groups and panchayati raj institutions.

#### *Land use constrained by lack of effective implementation*

The existing availability of wasteland indicates that nearly 13.4 million hectares of land would be used for cultivation of jatropha as indicated by the following facts:

1. Out of the total forests cover of 69 million hectares, 3 million hectares can be used for Jatropha curcas plantation.
2. The existing land under agriculture is 142 million hectares. Farmers can plant jatropha on the hedges for plant protection, which would cover 3 million hectares of land.
3. Culturable fallow lands is estimated to be 24 million hectares, of which current fallow lands are 10 million hectares and other fallows are 14 million hectares. 10 per cent of such land (2.4 million hectares) is expected to come under Jatropha curcas plantation.
4. Integrated Watershed Development and other poverty alleviation programmes of Ministry of Rural Development has the potential to ensure 2 million hectare of jatropha plantation
5. On vast stretches of public lands along railway tracks, roads and canals, one million hectare of notional coverage with Jatropha curcas is a reasonable assessment.
6. In addition, about 4 million hectares of wastelands could also be brought under such plantation.

However, the implementation of the plantation programme is highly dependent on the various government programmes. These programmes are being implemented by the Ministry of Rural Development to generate employment opportunities. Hence, success of the plantation programme is unlikely to yield results in the medium term. The biodiesel policy has also not offered financial support which could encourage farmers to undertake jatropha cultivation.



### High crude oil prices make biodiesel attractive

The availability of biodiesel depends on the profitability of three segments- farmers, processors and the oil marketing companies. Since the plantation of jatropha is not profitable as compared with the main crops, it would be cultivated on marginal lands or on wastelands. The returns to farmers would be affected by seed prices and labour cost. The current seed prices of Rs 8 per kg would result in higher returns for the farmers. However, prices would decline with improvement in supply, thereby affecting the returns.

The returns of processors would depend on seed prices, as the procurement prices of biodiesel are currently fixed by the government. Their returns are likely to improve with falling seed prices. Oil marketing companies will benefit, as the cost of biodiesel at Rs 27 per litre will be competitive as compared with the ex-storage price of diesel at crude oil prices above \$50 per barrel.

### Biodiesel procurement chain

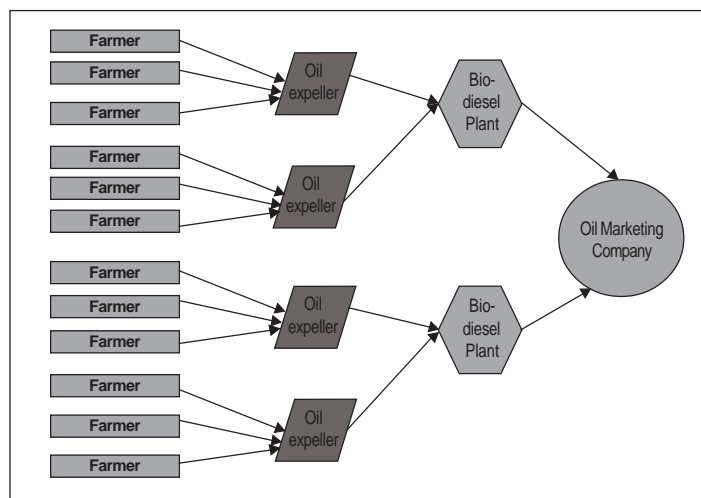

SOURCE: CRISIL RESEARCH

Note: The oil expeller could be at the farmer or at the biodiesel plant. The oil expeller converts non-refined jatropha oil to biodiesel.

### Lowering seeds cost to improve margins for processors

The crude non-edible oil recovered from jatropha seeds need to be refined by the process of transesterification to make it suitable for blending with diesel. The initial extraction of the oil from the seeds can also be done at the transesterification plant. The seed, seed collection, oil extraction, oil transesterification, transportation of seed and oil are the various cost components involved in the process. The process also yields by-products such as oil cake (used as organic manure) and glycerol (used in soap industry).

Decline in seed prices, along with increase in supply and realisation from the by-products, is likely to improve the margins for processors. The availability of jatropha has been low due to limited plantation of seeds. The requirement of jatropha seeds for biodiesel plantation has pushed up prices of seeds to Rs 8 per litre. As seeds constitute a major cost for the processor, greater availability would improve the margins at the current procurement prices of Rs 26.50 per litre. The sensitivity of seed prices and the current price offered for biodiesel indicate that the processors will earn negative returns at the current prices of jatropha seeds. However, as augmenting supply pushes down the price of seeds, the returns are expected to improve.

### High crude oil prices justify focus on biodiesel for oil marketing companies

The biodiesel purchase policy has fixed the price of biodiesel at Rs 26.50 per litre for oil marketing companies. The blending of biodiesel by the OMC would be driven by the supply as well as the savings possible on account of under recovery due to sale of diesel at controlled prices. The present high crude oil price scenario indicates that blending would be beneficial for the OMC.





### Blending at 5 per cent likely to save Rs 10.7 billion in 2011-12

The blending would be beneficial for the OMC if the cost of the biodiesel is lower than the diesel depot price. The diesel price at the depot inclusive of all taxes except sales tax is at Rs 30.42. Hence, the blending with biodiesel would result in savings of Rs 0.17 per litre. If the 5 per cent blending target (3,128 million litres of biodiesel) is met in 2011-12, OMCs would benefit to the tune of Rs 10.7 billion.

### Biodiesel blending benefit to OMC

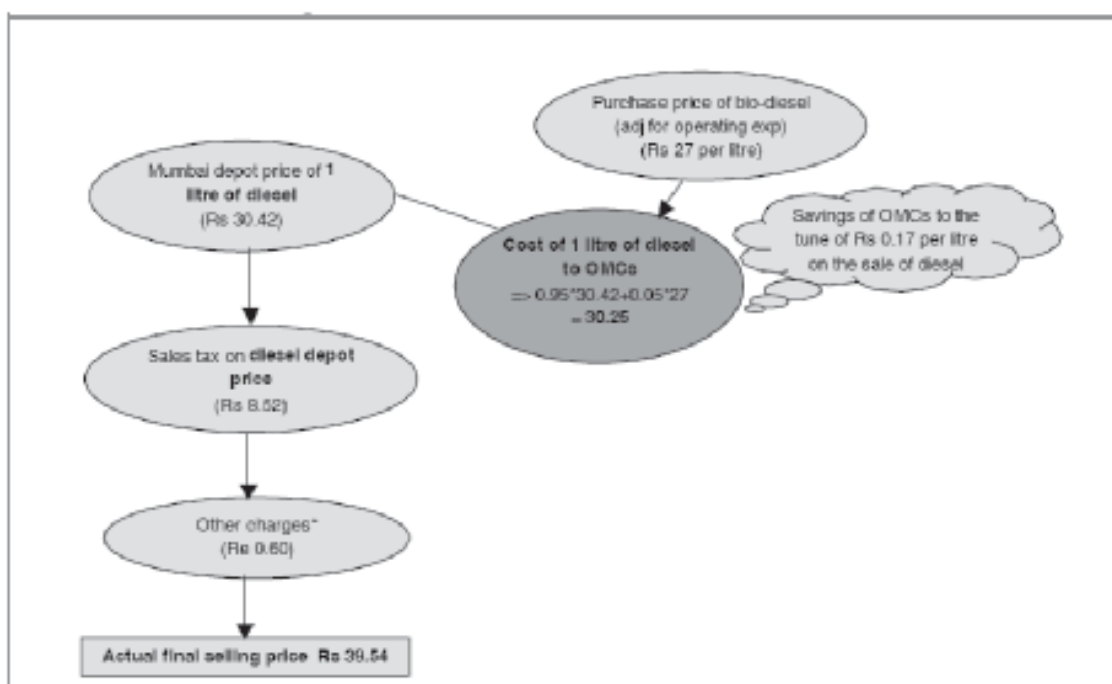

Source: CRISIL Research

### Blending beneficial at crude above \$71 levels

The current depot prices of diesel at Mumbai depot at Rs 30.42 per litre indicates equivalent crude oil price of \$82.5 per barrel (Brent crude). The blending is economical at this level as indicated before, as it would lead to savings of Rs 0.17 per litre. As the depot price will be driven by crude oil prices, the depot prices of diesel are estimated to remain higher than the current biodiesel cost of Rs 27 per litre, if the crude oil prices remain above \$71 per barrel (Brent crude).

The table indicates that the Mumbai depot price (ex-storage) will be lower at Rs 21 per litre if the crude oil prices reach \$50 per barrel. The comparison with biodiesel prices indicates that there is no benefit to the OMCs. Since crude oil prices have been much higher, the comparison with depot prices indicates that the OMCs will benefit from biodiesel blending.

### Industry structure

#### Players

#### D1-BP Fuel Crops Ltd

D1 Oils Plc is a UK-based company that produces biodiesel from a variety of crops. It started its operations in India by entering into joint venture with Mohan Breweries & Distilleries Ltd, and later with Williamson Magor and Co. Ltd, to develop jatropha plantations in India. In October 2007, a global venture between BP and D1 Oils plc was formed. The company provides technology and services for the breeding, development, planting and harvesting of new varieties of commercial biofuel crops with special focus on jatropha.

**Reliance Industries Ltd**

Reliance Industries Ltd (RIL) plans to cultivate jatropha on 200 acres of land at Kakinada, Andhra Pradesh, which can yield high quality biodiesel. The company proposes to start an esterification plant after having sufficient land under cultivation. The project is being implemented by Reliance Life Sciences, a subsidiary of RIL.

**Godrej Agrovet**

Godrej Agrovet Ltd proposes to invest over Rs 5 billion for jatropha and palm oil cultivation in the states of Gujarat and Mizoram. The company would cultivate jatropha or palm oil according to the nature of the waste land in these states. Godrej Agrovet plans to invest Rs 2.5 billion for bio-fuel plant cultivation along with the palm oil processing and plant cultivation project in Gujara. The company would invest the balance for both jatropha and palm oil cultivation in Mizoram. Godrej would cultivate both jatropha and palm oil in an area spanning over 10,000 acres in Mizoram as per the fertility of the land.

**Emami group**

India.s Emami Biotech, part of the Emami Group, expects to commission its Rs-1.5-billion, 100,000-tonne/year biodiesel plant at Haldia in West Bengal in 2008. This will be the first large biodiesel project undertaken in the organised sector in West Bengal, and would initially use palm oil as basic raw-material instead of jatropha. Several smaller Indian companies are already working towards developing biodiesel. Companies such as Nandan Bioagro and Labland Biotech have tied up with British oil company D1 Oils to produce jatropha and trade in it.

The company will encourage hundreds of farmers to cultivate the crop under an arrangement.

**Feedstock used for biodiesel production**

Country/Region	Preferred/ Suitable raw material
Europe	Sunflower, Rapeseed
USA	Soyabean
Thailand	Palm Oil
Ireland	Frying oil and Animal Fats
India	Non-edible oil from Jatropha curcas
France and UK	Sunflower

**Source: CRISIL Research**

There are many tree species that bear seeds rich in oil, possessing the properties of an excellent fuel, and which can be processed into diesel. There are number of promising species such as Pongamia pinnata (Karanja) and Jatropha curcas (Ratanjyot).

Jatropha curcas has been found most suitable due to various favourable attributes such as hardy nature, short gestation period, high oil recovery and quality of oil, etc. It can be planted on degraded lands through Joint Forest Management (JFM), farmer.s field boundaries, fallow lands and as agro forestry crop.

Jatropha curcas has been identified by the Planning Commission.s Task Force as the most suitable tree borne oil (TBO) seed plant for production of biodiesel in view of both the non-edible oil available from it and its presence throughout the country. The capacity of Jatropha curcas to rehabilitate degraded or dry lands, from which the poor mostly derive their sustenance, by improving water retention capacity, makes it additionally suitable for upgradation of land resources.

Advantage over other oil bearing tree species:

- Highest oil yield per hectare.
- It can be grown in most parts of the country.
- It is easy to establish, grows relatively quickly and is hardy.



- Plants are not very tall.
- It is not browsed by animals, as it produces latex.
- Being rich in nitrogen, the seed cake is an excellent source of plant nutrients.

**State-wise bio-fuel plantation potential and status**

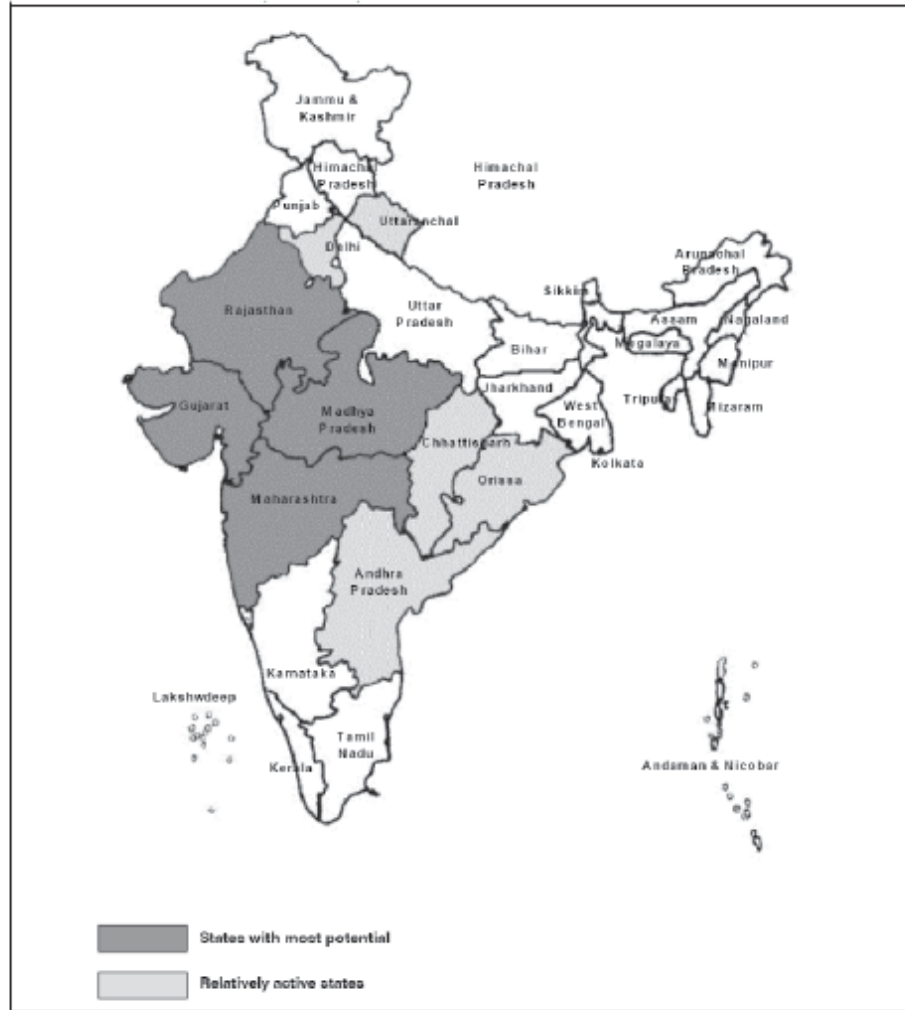



As a substitute for fast depleting fossil fuel. Bio diesel had come to stay. In future, it should also serve to reduce and maintain the price of automobile fuel. The under exploited and un exploited vegetable oils are good sources of biofuel. Our country is endowed with many such plants. Research is being carried out now to convert vegetable oils into biodiesel through biotechnological processes using biodiesel. With a concentrated and coordinated effort. Wide use of bio diesel in our country is going to be a reality in the days to come.

A national mission on Bio-Diesel has already been proposed by the committee comprising six micro missions covering all aspects of plantation, procurement of seed, extraction of oil, trans-esterification, blending & trade, and research and development. Diesel forms nearly 40% of the energy consumed in the form of hydrocarbon fuels, and its demand is estimated at 40 million tons.

Therefore blending becomes the important National Issue which apart from giving the dividends , it saves the country's exchequer. India has vast stretches of degraded land, mostly in areas with adverse agro- climatic conditions, where species of Jatropha , Mahua etc can be grown easily.

Even 30 million hectares planted for bio- diesel can completely replace the current use of biofuels. The production of Bio fuels will also boost the rural economy which will bring more enthusiasm in more than one billion lives in the area

(Source; Report of the committee on development of bio fuel- Planning commission , Govt of India )

CRISIL Disclaimer:

CRISIL limited has used due care and caution in preparing this report. Information has been obtained by CRISIL from sources which it considers reliable. However, CRISIL does not guarantee the accuracy, adequacy or completeness of any information and is not responsible for any errors or omissions or for the results obtained from the use of such information. No part of this report may be published/reproduced in any form without CRISIL's prior written approval. CRISIL is not liable for investment decisions which may be based on the views expressed in this report. CRISIL Research operates independendy of, and does not have access to information obtained by CRISIL's Rating Division, which may, in its regular operations, obtain information of a confidential nature that is not available to CRISIL Research.



## PESTICIDES/AGRO CHEMICALS INDUSTRY

Source : THE INDIAN PESTICIDES INDUSTRY- ICRA RESEARCH REPORT January 2008 –

### Overview

A pesticide is any substance or mixture of substances intended for preventing, destroying, repelling, or mitigating any pest. The pesticides (of which insecticides constitute an important segment) or the agrochemicals industry (hereinafter referred to as the PAC industry) primarily consists of insecticides, herbicides and fungicides.

While farmers have been doing pest management since the onset of agricultural production, the discovery of the pesticidal properties of synthetic chemicals in the middle of the 20<sup>th</sup> century has transformed agriculture. Dichloro-Diphenyl-Trichloroethane (DDT) is perhaps the best known chemical pesticide. DDT was discovered as an insecticide in 1939 and was used extensively in agriculture, and for public health programs. Subsequently, other insecticides, herbicides, and fungicides were developed. Their large-scale use started in farming in industrialised countries, resulting in large increases in production and/or cost savings on labour. The first Green Revolution, which began in the 1960s, made high-yielding crop varieties available to developing countries, especially in Asia. Exploitation of the production potential of these varieties stimulated the use of fertiliser and pesticides. This dynamic led to large increases in food production in many countries but also to growing pesticide use.

PACs provide vital inputs to crop protection and act as a vital input to agricultural produce. In a world-wide study of eight crops, it has been estimated that the global harvest losses due to pests was about 42% of attainable production. Higher yields can be assured by reducing crop losses caused by weeds, pests and insects. PAC have assisted in controlling pests and maintaining the availability of low cost and high quality food. They also allow for improved storage and distribution of crops, fruits, and grains.

The importance of PACs in India derives from the fact that that India is an agrarian society. Agriculture is the backbone of the Indian economy and contributes 18% of India's GDP. Nearly 70% of the country's work force derives its livelihood from agriculture. Higher crop productivity can be achieved through high-grade crop protection, and the challenge is to prevent or reduce pest related crop losses, which are presently estimated at around 20-25% of crops sown, i.e., approximately Rs. 250-300 billion per annum.

Pesticide use significantly contributes towards enhancing agricultural production and also helps to reduce the problems of vector-borne diseases. On the other hand, failure to adhere to the safety norms at various stages of pesticide production and use and also some times non-availability of credible information have caused serious concerns in the society. There are health risks associated with pesticides. By their very nature, most chemical-based PACs create some risk of harm to humans, animals, or the environment because they are designed to kill or otherwise adversely affect living organisms. These risks include on-farm ingestion by workers, discharge of toxic chemicals into the air and water, and consumption of foods that contain pesticide residues by consumers. Laboratory studies show that pesticides can cause health problems, such as birth defects, nerve damage, cancer, and other effects that might occur over a long period of time. However, these effects depend on how toxic the pesticide is and how much of it is consumed. Some pesticides also pose unique health risks to children. At the same time, pesticides are one of the vital ingredients of crop protection, and enhancing agricultural productivity.

### Categories of Pesticides

Pesticides are often referred to according to the type of pest they control. In such a classification, pesticides are normally categorised into the following major categories:

- ❑ insecticides act against insects which feed on crops, leaves, roots, and other parts of plants;
- ❑ herbicides (also known as weedicides) act against weeds or unwanted plants compete with the crop for nutrients, light, water, space.
- ❑ fungicides act against bacteria, fungi, virus and mycoplasma which cause various diseases in plants.

Other categories of pesticides include:

- ❑ algicides control algae in lakes, canals, swimming pools, water tanks, and other sites.
- ❑ antifouling agents: kill or repel organisms that attach to underwater surfaces.



- ❑ antimicrobials kill microorganisms (such as bacteria and viruses).
- ❑ fumigants produce gas or vapour intended to destroy pests in buildings or soil.
- ❑ miticides kill mites that feed on plants and animals.
- ❑ ovicides kill eggs of insects and mites.
- ❑ repellents repel pests, including insects (such as mosquitoes) and birds.
- ❑ rodenticides control mice and other rodents.

An alternate way to classify PAC is to consider those that are chemical pesticides or are derived from a common source or production method. Other categories include biopesticides, antimicrobials, and pest control devices.

Chemical Pesticides comprise the following:

- ❑ Organophosphate Pesticides were developed during the early 19th century, but their effects on insects, which are similar to their effects on humans, were discovered in 1932. Some are very poisonous (they were used in World War II as nerve agents). However, they usually are not persistent in the environment.
- ❑ Carbamate Pesticides
- ❑ Organochlorine Insecticides were commonly used in the past, but many have been removed from the market due to their health and environmental effects and their persistence (e.g. DDT and chlordane).
- ❑ Pyrethroid Pesticides were developed as a synthetic version of the naturally occurring pesticide pyrethrin, which is found in chrysanthemums. They have been modified to increase their stability in the environment. Some synthetic pyrethroids are toxic to the nervous system.
- ❑ Biopesticides are pesticides derived from such natural materials as animals, plants, bacteria, and certain minerals.

The Indian PAC industry primarily comprises of insecticides, fungicides, and herbicides/weedicides. Insecticides dominate consumption with around 62% of estimated consumption of PAC, followed by herbicides/weedicides (18%), fungicides (15%), and others (4%). Insecticides are used mainly for rice, cotton and vegetables; herbicides for rubber, oil palm, tea, and coffee; and fungicides for tobacco, vegetables, and bananas.

The per hectare consumption of pesticides in India is estimated at 0.5 kgs. However, this is not uniform. It varies vastly across the country with the agro-ecological settings, cropping pattern, irrigation facilities, intensity of pests and diseases, resistance and resurgence of insect pests, etc. Pesticide use is particularly high in regions with irrigation facilities and also in those areas where commercial crops are grown.

Cotton, paddy, vegetables and fruits account for over 80% of the pesticide consumption in the country. While cotton is planted on about 4.5-5% of the total cultivable area (on about 9.3 million hectares or mha), it accounts for about 33% of pesticide consumption in India, followed by rice (23%), vegetables (9%), wheat (8%), and pulses (6%).

At present, 209 pesticides have been registered in India. A Registration Committee (RC) has been constituted under Section 5 of the Insecticides Act, 1968 to register insecticides after scrutinising formulae, verifying claims of efficacy and safety to human beings and animals, specify the precautions against poisoning and any other function incidental to these matters. To assess efficacy of the insecticides and their safety to human beings and animals, the RC has evolved exhaustive guidelines/data requirements which inter-alia includes residue in crops on which the insecticides are intended to be used. The onus lies with the importers/manufacturers to generate data relating to the insecticides for which registration are sought. The Government of India (GoI) has been reviewing the continued use of the registered pesticides at periodical intervals by constituting expert committees. However, a large number of pesticides that fall under the extremely hazardous category of 1A & 1B of World Health Organisation (WHO) classification are yet to be phased out or banned despite recent reports linking some of them responsible for serious health hazards like cancer, congenital malformation, abnormality in reproductive system, etc. Such pesticides, still in use include (a) Extremely Hazardous—Aldicarb, Methomyl, Monocrotophos, Phorate, Phosphomidon; and (b) Highly Hazardous—Carbofuran, Dichlovos, Dimethoate, Endosulphan, Ethion, Fenthion, Fenvalerate, Methyl Parathion, Phosalone, and Triazophos.



### **Global Market for Pesticides**

The global market for chemical pesticides/agrochemicals was estimated at around US\$31.19 billion in 2006. The global market for pesticides declined 2.5% in 2006, as compared with a growth of 1.5% in 2005. In the period since 1991, the world market has increased from US\$23.30 billion, at an average rate of 1.8%. However, growth has not been uniform.

During 2004-05, the strong performance of the crop protection sector was predominantly due to a reversal of many of the negative factors that had depressed market performance in recent years. These included recovery from drought in Northern Europe and Australia, strengthening commodity prices, and improvement in the Latin American economy. Short term factors that also benefited sales were the Asian soybean rust outbreak in Brazil, excellent growing conditions in the US leading to record harvests and a buoyant farm economy, and high insect and disease pressure in Japan. The major negative factors were expansion of the area planted with genetically modified (GM) crops in the regions where the technology has been accepted and increasing competition in the US glyphosate sector, resulting in depressed herbicide prices.

Following the strong performance of the crop protection sector in 2004, many of the positive factors that benefited market performance were reversed in 2005. Commodity prices were weak following strong 2004 harvests; drought affected southern Europe; and drought also depressed southern Brazil and northern Argentina, whilst the strengthening of the Brazilian Real depressed the agricultural economy in the country. In Asia a variable monsoon season resulted in early season dry conditions in Thailand, Vietnam and India, whilst a late but excessive monsoon resulted in a significant reduction in cotton pest pressure in India and Pakistan. The North American markets benefited from a strong farm economy at the start of the year following the strong 2004 harvests, however increasing GM crop areas and a very competitive market, with late season drought affecting central parts of the US, limited the eventual market growth.

One of the major reasons for the market decline in 2006 was adverse weather conditions in Brazil, North America, Northern Europe, India and Australia. In addition, many of the negative factors that affected market performance in 2005 were repeated or exacerbated in 2006. Generally, agricultural commodity prices were low at the start of the year depressing the farm economy in developed markets, while the strength of the Real in Brazil significantly depressed farm incomes in local currency terms, reducing purchasing capability for crop protection products.

During 2007, market conditions have remained challenging, leading to an expectation of further market decline. The main positive trend is the rapid expansion of the biofuels sector, with the potential that this has for improving the demand for agricultural produce and subsequently the agricultural economy. The key feedstocks for ethanol production are maize in the USA, sugarcane in Brazil and cereals in Europe, whilst for biodiesel the most efficient source is palm oil. However, the focus in the Americas is soyabean oil and oilseed rape in Europe.

The markets for chemical pesticides have undergone rapid changes over the last decade. Overall pesticide use worldwide over the last decade has remained constant or declined. The reduction can be explained partly by changing crop prices, greater efficiency of pesticide use as a result of improvements in pest management practices and technology, increased adoption of GM crops, and IPM techniques aimed at both improving pest management practices, and in some cases targeting a reduction in pesticide use.

Since biotech/GM crops were first commercialised in 1996, farmers have consistently increased their plantings of biotech crops by double-digit growth rates every single year since. In 2006, global area of GM or biotech crops increased 13% to 102 mha (252 million acres or ma). The majority of these sales continue to be derived from North and Latin America, although uptake in other regions is increasing, particularly in China and India. The focus of GM crop development is in the soyabean, maize, cotton and canola sectors; however in many of the countries where GM varieties have been accepted, the area cultivated with these varieties is now approaching maturity.

### **Indian Market**

India ranks 4<sup>th</sup> in world PAC production after US, Japan, and China. With estimated domestic consumption of around 39 thousand metric tonnes (TMT), India's PAC market is estimated at around Rs. 18 billion. In addition, India's PAC exports are estimated at 110.7 TMT in FY2007, valued at around Rs. 28.77 billion.



The Indian PAC industry is fragmented with more than 60 technical grade pesticides being manufactured indigenously by 125 producers consisting of around 60 large and medium scale enterprises (including about 10 multinational companies) and more than 500 pesticide formulators spread all over the country. The organised sector comprises multinational corporations (MNCs) and Indian players. Besides the presence of MNCs such as Monsanto, Bayer, and Syngenta, there are many major Indian players such as United Phosphorous, Excel Industries, and Rallis India. Most Indian companies manufacture off-patent pesticides, which comprise over 70% of the Indian market.

Traditionally, the Indian players in the PAC market have focused on marketing generic and off-patent products, whereas the MNCs have focused on high-end specialty products. The Indian companies are playing to their basic strengths, which are low-cost manufacture, applied research and extensive distribution. Indian players focus on applied research, which include developing processes to manufacture off-patent products, more effective methods of delivering existing products, and new formulations (or combinations) of generic products. They generally do not have the financial and technical resources for undertaking basic research. The MNCs dominate the market for proprietary products (patented new molecules). They have the advantage of access to the R&D pipeline and superior financial resources of their parents. Despite the threat of generic products, MNCs have introduced quite a few of their top selling global products in the Indian market. Monsanto holds Indian registrations for almost the entire complement of global brands. The Indian operations of MNCs have also tried to guard against the cyclical nature of the domestic market, by identifying and sticking to niche categories, crops and markets within the industry. MNCs have also been working at strengthening the linkages with the farmers through extension and advisory services. Many MNCs have also entered into supply arrangements with their parents to take advantage of the cost advantage in manufacturing from the Indian facility. Due to medium capital intensity (Operating Income/assets of 0.7), and Government policy of encouraging the small-scale sector, intense competition exists. Distribution reach, new product launches, and ability to extend credit to the farmers influence sales.

The onset of the product patent regime in 2005 can lead to relatively better prospects for the MNCs in the business. In the post-2005 scenario, the Indian market can expect to witness an inflow of new molecules from MNCs. The domestic industry would have to meet this competition through development of new molecules, process and product development, development of new formulations and by better product customisation. Almost 70% of all agrochemicals present in use in India are off patent. In the new product patent regime, in which MNCs are expected to bring in new molecules, the domestic players would need to focus on technology development for bio- and botanical pesticides.

#### *Key Issues Facing the Players*

##### ***cyclical Nature of Demand***

Overall pesticide usage by farmers depends on a multitude of factors, such as climatic conditions, the area under cultivation, composition and variety of crops, pest and disease pressures, farm incomes, pesticide cost/crop price ratios, pesticide policies and management practices.

The demand for PAC in India is seasonal and cyclical as it largely depends on agricultural production. PAC demand is skewed in favour of kharif crops such as cotton and rice, with kharif crops accounting for around 70% of annual consumption of PAC. The peak consumption of PAC is during July-November. As the business is highly seasonal, PAC companies have to build up inventory in advance of the season by making assumptions about the monsoon and crop acreage situation.

As stated above, overall PAC consumption primarily depends on agricultural production, which in turn is highly dependent on rainfall. The ratio of net irrigated area to net sown area is 40% in India. Droughts/deficient monsoons not only adversely impact kharif sowing season (beginning in July) but also kharif production and agricultural incomes. They also impact water reservoirs and rabi production. Adverse monsoons also impact the agricultural input purchasing capacity and loan repaying ability of farmers. Apart from agricultural production growth, consumption of PAC also depends on the pest pressure. If weather conditions are such that there are more insects, then farmers are likely to use more insecticides. Even if monsoons are adequate, the attack of insects or diseases may or may not be very high. Demand growth is a very complex result of various weather conditions, and unpredictable events like pest pressure and attack of disease impact PAC consumption.

India's PAC production had peaked at around 95,000 metric tonnes (MT) in FY2000. Since then, production





has declined to 84,701 MT in FY2007. PAC consumption has declined on a long-term basis because of IPM techniques and higher adoption of GM cotton. In view of its positive impact in cotton production due to control of boll worms, the area under Bt./GM cotton has increased from 0.03 mha in 2002-03 to 3.46 mha during 2006-07. At present, Bt. cotton is the only GM crop approved for commercial cultivation by the Genetic Engineering Approval Committee (GEAC) of Ministry of Environment & Forests on the basis of bio-safety and suitability for different regions of the country.

During FY2007, pesticides production and domestic consumption has grown at a slow rate mainly because of a 180% increase in area under Bt. Cotton. The cumulative rainfall under the South-West monsoon season (June-September) 2006 was 99.9% of normal. Of the 36 meteorological subdivisions, cumulative rainfall was normal/excess in 26 subdivisions (32 in 2005), and deficient/scanty/no rain in 10 subdivisions (4 in 2005). At the district level, 60% of the 533 reported excess/normal rainfall, while the rest received deficient/scanty/no rain. Uneven and delayed rainfall during the South-West monsoon season led to some reduction in the area coverage under kharif crops in 2006 season; this decline was largely offset by improved sowing under rabi crops on account of favourable soil moisture conditions and remunerative open market and support prices. Significant improvement in the area sown was also observed in the case of rabi crops such as wheat, pulses, maize and barley, which more than offset the decline witnessed in oilseeds. India's cotton production is estimated to have increased 14.8% during 2006-07 to 4.76 million tonnes (mt) mainly because of an increase in acreage and higher yields. Most cotton growing areas received sufficient rains in July-August 2006 providing optimal planting and growth conditions. Some pockets in the central states of Gujarat and Maharashtra received heavy rains in August 2006 causing flooding resulting in some crop damage. However, these rains also replenished soil moisture and improved yield prospects in this major non-irrigated cotton belt, partially offsetting the flood damage.

During FY2008, India's PAC production and consumption is expected to decline because of a sharp increase in acreage under GM cotton. According to the forecast by the Indian Meteorological Department (IMD), the rainfall during the 2007 South-West monsoon season was likely to be 93% of the long-period average (LPA), with a model error of +/- 4%. However, the cumulative rainfall during the South-West monsoon season 2007 was 5% above normal. The area coverage of kharif crops increased during 2007-08 (as on October 26, 2007) with an increase of 2.8% over the previous year. While foodgrain crops such as pulses and rice have shown improvement in area sown, coarse grains witnessed a decline. Among non-foodgrains, most cotton growing areas received good late-season rains in September 2007 resulting in excellent growing conditions for the crop. As of October 26, 2007, total area sown under cotton was 5.5% (year on year or yoy) higher at 9.30 mha. Based on the latest cotton planting estimates in various states, area under cultivation is expected to be around 9.53 mha during 2007-08. Because of a 4.2% increase in acreage to 9.53 mha and a 6.1% increase in yields to 553 kg/ha, India's cotton production is expected at around 5.27 mt during CY2008. Although cotton acreage has increased in 2007-08, there are indications of even higher adoption of GM cotton. Area under Bt. Cotton is expected to increase from 3.46 mha in 2006-07 (representing 38% of the total cotton acreage) to 5 mha in 2007-08 (representing 53% of the total cotton acreage). Further, the incidence of pest & diseases remained below Economic Threshold Level (ETL) generally for most of the crops.

#### India's Pesticides Consumption and Agricultural Production

FY	2003	2004	2005	2006	2007	2008
PAC Volumes						
Consumption	48.4	41.0	40.7	39.8	38.0	
Production	69.6	85.1	94.0	82.2	84.7	
Foodgrains—mt	174.77	213.19	198.36	208.60	216.13	
Of which rice	71.82	88.53	83.13	91.79	92.76	
Wheat	65.76	72.15	68.64	69.35	74.89	
Non-foodgrains—mt						
Of which cotton	2.31	3.04	4.13	4.15	4.59	5.3



As can be seen, the domestic production of PAC is higher than consumption, with the surplus being exported. In recent years, export volumes have increased, which have partially compensated for declining domestic consumption.

Pesticides are used by around 46% of farmers during kharif and 31% of farmers during the rabi season. India's pesticides consumption is also constrained by the availability of pesticides within a reasonable distance. Pesticides are available within the village for only 19% of farmers, as compared with 27% for fertilisers, and 68% for organic manure. Amongst the states, pesticides usage is high in West Bengal, AP, and TN, but low in MP, Rajasthan, and UP.

#### Proportion of Farmers Using Pesticides during 2003-04

percent

State	Kharif	Rabi
Andhra Pradesh (AP)	71	30
Assam	51	48
Bihar	40	6
Chhattisgarh	38	5
Gujarat	48	25
Haryana	36	43
Jammu & Kashmir (J&K)	40	33
Jharkhand	46	16
Karnataka	55	21
Kerala	36	27
Madhya Pradesh (MP)	28	23
Maharashtra	55	17
Orissa	41	10
Punjab	52	52
Rajasthan	18	19
Tamil Nadu (TN)	65	26
Uttar Pradesh (UP)	39	35
West Bengal (WB)	80	65
<b>All-India</b>	<b>46</b>	<b>31</b>

#### Shift in Government Policies in Recent Years

The PAC industry is highly sensitive to Government's policies. The industry is regulated by two ministries. While the Department of Chemicals and Petrochemicals under the Ministry of Chemicals and Fertilisers promotes production of pesticides; the Ministry of Agriculture monitors the quality and supply of pesticides. Since pesticides are toxic and hazardous to humans and environment, and also enter into the food chain, the GoI regulates manufacture, sale, transport, export/import under Insecticides Act, 1968. Under the Act, no pesticides are allowed for production/import without registration.

The PAC industry developed in India because of the GoI's policies of self-reliance across the board, protection of domestic industry, and assured demand because of the large agricultural production. The GoI has also been framing various policies towards financing of farmers. Effective 1998-99, banks have been issuing Kisan Credit Cards to farmers on the basis of their land holdings so that the farmers can use them to readily purchase



agricultural inputs such as seeds, fertilisers, and pesticides and draw for their production needs. Over the last couple of years, the Kisan Credit Card Scheme has emerged as an effective tool for catering to the short-term credit requirements of the farmers.

In recent years, because of increased self-reliance in PAC production, the GoI has reduced customs duties on imports of PAC. While the Union Budget 2003-04 resulted in reduction in customs duty to 25% on all pesticides, the Mini-Budget reduced peak customs duty to 20%. The Union Budget for 2007-08 reduced the peak rate of customs duty to 10%. In the Union Budget for 2000-01, the GoI also increased excise duty on pesticides from 8% to 16%.

In recent years, the PAC industry has diversified into manufacture of biopesticides and synthetic pesticides. Biopesticides are becoming increasingly popular and often are safer than traditional chemical pesticides. In India, after the GoI decided to ban hexachlorobenzene (HCB) in April 1997, an estimated 300,000 tonnes of HCB has been eliminated from use. HCB represented 30% of India's total PAC consumption. The void created by HCB did not impact consumption or export, as biopesticides, botanical pesticides, and synthetic pyrethroids, replaced HCB.

In India, only 12 biopesticides have been registered. The consumption of biopesticides has also increased from 219 MT during FY1997 to around 1,000 MT at present. Various steps taken by the GoI to promote the usage of biopesticides include simplification of the guidelines for registration of biopesticides; encouraging farmers, local entrepreneurs, non-governmental organisations (NGOs) for production of biopesticides; provision of assistance as grants-in-aid for research, development, and production; provision of grants-in-aid provided to the States for infrastructural development for production of biocontrol agents and biopesticides; and allowing commercialisation of biopesticides.

Concern about the adverse effects of chemical pesticides due to their indiscriminate use is growing. Pesticides residues are being found increasingly in Indian farm produce posing a threat to human health. Because of the increased realisation of the harmful impact of pesticides, the GoI promoted the integrated pest management (IPM) in 1985, as an eco-friendly strategy of pest containment by exploiting the role of natural agents/forces in harmony with other pest management practices. The GoI has introduced IPM at the central and state levels for purposes of plant protection. IPM was adopted as a national policy in 1995 and it was implemented as large-scale demonstrations cum training in farmer fields in a wide range of crops including cotton. As a major policy change, the GoI also withdrew the subsidy component on pesticides since 1994-95 to facilitate promotion of IPM in the country. In India, 28 central IPM centres have been established in many states for pest surveillance and monitoring, promotion of bio-control methods of conservation, promotion of non-chemical methods of pest control, training of extension workers and farmers, etc. *IPM is discussed in further detail below.* The 10<sup>th</sup> Five-Year Plan envisaged a strengthening of IPM infrastructure, especially for surveillance and forecasting the outbreak of pests and diseases and production/multiplication of bio-control agents for field use. Besides, reliable methods of forecasting are expected to be developed and efforts would be made to make bio-control agents available on demand to farmers to help them adopt IPM. IPM has contributed significantly to the decline in consumption of chemical pesticides.

The GoI is also encouraging lower PAC consumption because of safety regulations on import of food products in various countries (which regulate the quantity of pesticide residues). High level of pesticide residues can often act as a constraint against increased agricultural exports. Various developed countries require documented data on pests and disease status. Such markets can only be accessed after introduction of a regular system for monitoring through survey and surveillance of different production belts of major crops. Rejection of even one shipment because of the discovery of an unknown pest at a port or high pesticide residues can result in the exporting country being placed on a quarantine list for that commodity, thus eliminating one import market. Repeated violations of residue requirements can result in automatic detention (inspection or fumigation or both) of all shipments from a country until it can document sufficient pre-inspection quality control. In the past, Japan, Australia and China have banned imports of mangoes and grapes from India on account of presence of certain fruit flies. Japan desires Vapour Heat Treatment (VHT) of fruits for disinfestations before these can be allowed to enter into their country.

**State-wise Consumption of Pesticides**

MT

FY	1996	2000	2001	2002	2003	2004	2005	5-year CAGR
AP	10,957	4,054	4,000	3,850	3,706	2,034	2,133	-12.1%
Bihar	1,383	832	853	890	1,010	860	850	0.4%
Gujarat	4,560	3,646	2,822	4,100	4,500	4,000	2,900	-4.5%
Haryana	5,100	5,025	5,025	5,020	5,012	4,730	4,520	-2.1%
Karnataka	3,924	2,484	2,020	2,500	2,700	1,692	2,200	-2.4%
Kerala	1,280	1,069	754	1,345	902	326	360	-19.6%
MP	1,748	1,528	871	714	1,026	662	749	-13.3%
Maharashtra	5,097	3,614	3,239	3,135	3,724	3,385	3,030	-3.5%
Orissa	1,293	998	1,006	1,018	1,134	682	692	-7.1%
Punjab	7,200	6,972	7,005	7,200	7,200	6,780	6,900	-0.2%
Rajasthan	3,210	2,547	3,040	4,628	3,200	2,303	1,628	-8.6%
TN	2,080	1,685	1,668	1,576	3,346	1,434	2,466	7.9%
UP	8,110	7,459	7,023	6,951	6,775	6,710	6,855	-1.7%
West Bengal	4,213	3,370	3,250	3,180	3,000	3,900	4,000	3.5%
Others	1,105	912	1,008	913	1,115	1,522	1,389	8.8%
<b>TOTAL</b>	<b>61,260</b>	<b>46,195</b>	<b>43,584</b>	<b>47,020</b>	<b>48,350</b>	<b>41,020</b>	<b>40,672</b>	<b>-2.5%</b>

**Crop-wise Consumption of Pesticides in India**

Crop	Share of Pesticide Use
Cotton	32%
Paddy	23%
Vegetables	9%
Wheat	8%
Pulses	6%
Plantation Crops	6%
Fruits	5%
Other	12%
<b>Total</b>	<b>100.0%</b>



## DEMAND SUPPLY POSITION

The demand-supply position of pesticides for the last few years is presented below:

### Demand and Supply of Pesticides

Thousand MT

FY	2001	2002	2003	2004	2005	2006	2007
Domestic Production	92.3	81.8	69.6	85.1	94.0	82.2	84.7
Domestic Consumption	43.6	47.0	48.4	41.0	40.7	39.8	39.5
Exports	47.9	50.1	55.7	69.0	79.1	94.5	110.7
Imports	5.9	7.2	6.8	12.6	18.5	22.8	24.9

As can be seen from the table above, the demand for pesticides in India has declined, because of slow growth in agricultural production, increase in GM CROP area under of pesticide-using agricultural products, and steady progress in the implementation of IPM. Since the 1990s, the most important factor behind the slow growth/decline in PAC consumption has been the slowdown in agricultural production. During the 1990s (1989-90 to 1999-2000), the growth of agriculture decelerated as compared to the 1980s (1979-80 to 1989-90). The overall annual growth rate of crop production declined from 3.72% to 2.29%. Productivity growth also declined from 2.99% to 1.21%. The consumption of pesticides also seems to have declined because of the propagation of the IPM approach, and increasing awareness about the hazards of pesticides.

Responding to the slow-down in domestic demand, production has also declined from 95.3 thousand MT in FY2000 to an estimated 84.7 thousand MT in FY2007. However, production has still been in excess of domestic demand. As a result, the Indian PAC industry has increasingly resorted to exports over the past few years. Export volumes of pesticides have increased from 40.7 thousand MT in FY2000 to 110.7 thousand MT in FY2007.

However, unit export realisations have declined because of the depressed state of world pesticides demand, and increased competition caused because of excess capacities.

### OUTLOOK

Modern techniques of farming have led to an increased dependence on chemicals in order to enhance food production and security. Pesticides are one of the major agro-inputs that have significantly contributed to food security in India. The domestic consumption of PAC is dependent on agricultural production, which is largely dependent on rainfall. However, domestic consumption of PAC has declined at a 5-year compounded annual growth rate (CAGR) of 2%. The overall pesticide use in India over the last decade has declined. The reduction can be explained partly by changing crop prices, greater efficiency of pesticide use as a result of improvements in pest management practices and technology, substantially higher adoption of GM cotton, and government policies aimed at both improving pest management practices, and in some cases targeting a reduction in pesticide use. Use of integrated nutrients through chemical fertilisers and organic sources is also being encouraged so as to improve and maintain soil fertility and make cheaper source of plant nutrients available to the crops. Apart from promoting IPM, the GoI has also been periodically reviewing the continued use/restriction/ban of specific pesticides reported to be hazardous. Because of declining domestic consumption, production has also declined in recent years. Over the years, the export market has increasingly provided a cushion to the vagaries of the domestic market. Out of the combined turnover of Rs. 47 billion, the export turnover is around Rs. 29 billion. An export-oriented strategy has the potential to deliver rapid expansion in volumes and provide better insulation from the cyclicalities of the domestic market. Over the years, Indian PAC companies have developed process technologies for many PACs, and PAC exports have increased significantly in recent years. The easy availability of raw materials, low-cost trained and skilled workforce, low overheads, and technically qualified managerial base is likely to make India an attractive sourcing destination for global MNCs. Many overseas companies are also undertaking collaborative research with local companies and institutions.

Though pesticides have contributed to India's growing food production, they have also paved the way for serious outbreaks of pests and diseases as well as damage to bio-diversity and environment. Despite use of pesticides, pest outbreaks continue in many crops; and many pests like bollworms and whitefly in cotton,



brown planthopper (BPH) in rice, *Spodoptera litura* in groundnut have developed manifold resistance due to indiscriminate use of pesticides. The ill effect of pesticides has also led to the significant natural pest-enemy population in the cotton, rice and groundnut eco-system.

Given the current reliance on chemical pesticides, along with the uncertainties about many non-chemical approaches, it is unlikely that there will be pesticide-free agriculture over the next decade. Rather, it is highly probable that the forms of IPM that will be encouraged will include a greater reliance on biological approaches and the judicious use of some chemical pesticides. Greater attention is likely to be paid to applying the right quantities of pesticides at the appropriate times and safeguarding the natural enemies of pests. At the same time, IPM will also incorporate the use of crop rotations and pest-resistant varieties of crops.

Another important issue regarding pest management in the future centers on the role of biotechnology in crop production. The present decade is likely to see a substantial increase in the production of GM crops. Genetically engineered plants have been designed to resist pests such as stem borers and nematodes without the need for pesticides. Others are expected to combine both herbicide resistance and insect resistance in one seed. Higher adoption of GM crops has resulted in a decline in pesticide usage. There are concerns, however, that the rapid diffusion of improved varieties may well lead to pest resistance, including the possible transfer of genetic qualities from modified plants to weeds, creating new generations of weeds resistant to herbicides. There are also concerns about the long-term effects of increased consumption of genetically altered materials on both humans and animals.

Policymakers and stakeholders interested in effective crop protection have to balance the social benefits and costs of pesticide use. Options for improving pest management include the development of pesticides that are more benign than current products. IPM promises to be the most pragmatic approach. Genetically engineered crops offer great promise but need to be monitored. Developing countries such as India will have to invest in their own technological capacities or enter into sharing arrangements with MNCs.

Source : ICRA Report on The Indian Pesticides Industry January 2008



## 2. OUR BUSINESS

Our Company was incorporated on September 29, 1995 with the main objective of manufacturing of Agro Chemicals.

### **Agro Chemical Activity**

Andhra Pradesh stands first in agro chemical consumption in India as far as the state wise markets are concerned. The average stable growth is between 3-5% (Approximately) in the domestic market every year based on GDP and more specifically agriculture growth. Our Company has been predominantly concentrating in coastal districts of Andhra Pradesh, where paddy is grown extensively.

Our Company's main products are in three forms viz., liquids, granules and dusts. Our Company has CIB registrations for 34 products to manufacture pesticides for crops i.e. Paddy, Cotton, Sugarcane, Turmeric, Chillies, Pulses, Vegetable etc., of which it is currently manufacturing 17 products.

### **Our Team and Management :**

Our Chairman Mr. Kanuparthi Balakrishna Rao , who has more than 40 years of experience in this Industry, has been instrumental in guiding the board in formulation of strategy and planning. Our managing director Mr. K.T Vijaya Kumar with more than 27 years experience in this industry has overall control over day to day activities of our Company and has been able to motivate our key managerial personnel to create a team of dedicated techno commercial marketing staff, dealers and distributors.

### **Distribution Net work:**

Our distribution network consists of distributors and dealers in 5 districts of Andhra Pradesh . We have more than 18 distributors who help us in selling our products to end users through the chain of more than 350 direct dealers and 550 retailers. We hold regular farmers meets at different places to educate and disseminate new methods of the plant protection with the help of our techno commercial marketing sales staff, dealers and distributors. With the help our distribution network & marketing team, we keep ourselves updated about the occurrence of a particular pest. Based on this information and our experience, we reschedule our production and distribution. We have established strong dealer network spread through out 5 districts of A.P wherein we maintain adequate stocks to make our products available at short notices. This strategy helps us in selling our products effectively.

### **Our Product Range:**

We have 34 products in our product portfolio which consists of different kind of insecticides. We manufacture various formulations comprising of liquids, granules and powder formulations. Our products are available in various sizes of packaging catering to the needs of small, marginal and large farmers. Our product range covers most of the crops and majority of plant infections. We provide end to end plant protection solutions to farmers through our distributors. Our product range helps us in attracting large distributors of agrochemicals to become our distributor.

### **Our Products:**

We have certificate of registrations for 34 formulations. Our largest selling formulations are CHEMCEL HEXA; COUNTER; COSY; CELPHATE". We carry out product awareness exercises with the help of advertisement. Our product quality awareness helps us in getting repeat purchases by end users.

### **Our Production Facilities**

Our Company has set up production unit at Kanuru, Vijayawada, Andhra Pradesh for production of a wide range of pesticides. which is very close to rice belts of Krishna & Godavari districts, and commercial belts of Guntur and Khammam. Land is very fertile and farmers have been taking 2 crops around the year in the area. We have semi-automated granule sections, and semi-automatic liquid lines, chemical resistant reactors for insecticides. We have laid out a Quality Assurance plan for all products and practices Quality Control checks, testing and inspection at all stages. In recognition of the quality system, established by our Company in respect of manufacturing, formulation and marketing of agrochemicals, is a set of rules that companies follow to assure that they have the systems needed to meet their customers' needs.



Our Company's main products are in three forms viz., Liquids, granules and dusts. Individual capacities of these products are as under:

Liquids	1000 KL/per year
Granules	1000 MT/per year
Dusts	300 MT/per year

Our Company has CIB registrations for 34 formulations to manufacture pesticides for crops i.e. Paddy, Cotton, Sugarcane, Turmeric, Chillies, Pulses, Vegetable etc., of which it is currently manufacturing 17 formulations.

#### PRIMARY PRODUCT DESCRIPTION

PRODUCT NAME	TECHNICAL NAME	USAGE	APPLICABILITY
CHEMCEL HEXA	HEXACONAZOLE-5% EC	Fight against sheath blight; control Leaf spots, Leaf streaks.	Rice plants.
COUNTER	IMIDACLOPRID -17.8% SL	Effective against Brown Plant Hooper.	Rice, Chillies, Cotton.
COSY	TRICYCLAZOLE -75% WP	Effective against 'Blast' symptoms.	Rice crops.
BUMPER	CYPERMETHRIN -10% EC	Control of caterpillars and Boll Worms	Different commercial crops.
CARE	LAMBDA CYHALOTHRIN -2.5% EC	Controls caterpillars and sucking pests.	Different commercial crops.
CHASE	CHLORPYRIPHOS -20% EC	Control Leaf Roller and Gall Midge stem borer of Paddy, Boll Worms and cut fly of cotton, insects of sugarcane etc.	Paddy, Sugarcane, Wheat, Barley.
MONOCEL	MONOCROTOPHOS -36% SL	Control Brown Plant Hooper, Green Leaf Hooper, Yellow stem borer of Paddy, and Shoot stem fly of Maize, Pod Borers of Bengal Gram etc.	Paddy, Maize, Green gram, Black gram Pea, Sugarcane.
CELPHATE	ACEPHATE- 75% SP	Control Boll Worm, Jassids, Aphids.	Cotton and Sunflower.
QUINTOX	QUINALPHOS -25% EC	Control Brown Plant Hooper, blue beetle, leaf roller, stem borer of paddy, might and shoot fly of sorghum, ear head of caterpillar, insects of pulses etc.	Paddy, Wheat, Cotton, Oilseeds, Pulses.
LEAD	CARBENDAZIM-50% WP	Control Blast & sheath blight of paddy, loose smut of wheat and barley, brown rot of maize, powdery mildew of sugar beet, peas, cluster bean, damping of chillies etc.	Paddy, Wheat, Maize, Cluster beet, Rose, Ber, Grapes, Tobacco, Chillies and Apples.
CHASER	Chlorpyriphos 50% + Cypermethrin 5% EC	Controls against all types of caterpillars	Chillies, Cotton, Vegetables, all Orchard crops
HEXA PLUS	HEXACONAZOLE 5% SC	Controls against Sheath blight in rice	Rice plants





As on date, this division has CIB registrations for the following formulations:

**Name of the Product**

1. Acephate-75% SP
2. Cypermethrin-25% EC
3. Cypermethrin-10% EC
4. Chlorpyrifos-20% EC
5. Carbendazim-50% WP
6. Copper oxychloride-50% WP
7. Dicofol-18.5% EC
8. Ethion-50% EC
9. Endosulfan-35% EC
10. Fenvalerate-20% EC
11. Hexaconazole-5% EC
12. Imidacloprid-17.8% SL
13. Lambda Cyhalothrin-5% EC
14. Lambda Cyhalothrin-2.5% EC
15. Monocrotophos-36% SL
16. Propiconazole-25% EC
17. Quinalphos-25% EC
18. Tricyclazole-75% WP
19. Ethion-40% + Cypermethrin-5% EC
20. Acetamiprid-20% SP
21. Hexaconazole-5% SC
22. Chlorpyrifos-50%+Cypermethrin-5%EC
23. Dimethoate 30 % EC
24. Indoxicarb 14.5%SC
25. Carbendazium 12% + Mancozeb 63% WP
26. Traizophos 40% EC
27. Mancozeb 75% WP
28. Cartap Hydrochloride 4% GR
29. Carbofuran 3% C.G.
30. Chlorpyrifos 10% GR
31. Imidacloprid 70%
32. Validamycin 3% L
33. Indoxacarb 14.5% SC
34. Dichlorovos 76% EC



**Product Usage:**

The products manufactured by our Company are useful for fighting insecticides & fungicides in crops like cotton, paddy, chillies, vegetables, pulses etc. The end user of these products is farmer.

**MANUFACTURING PROCESS**

**Pesticides Formulation**

The Pesticide formulations are prepared from liquids/E.Cs, Dust particles and Granules

**Dusts/Wettable powders:**

The plant and machinery required for wettable powder manufacturing is hammer mill and/or pulverizer. Each raw material is weighed and fed as per BIS standard into pre mixing blender which is then sent to hammer mill for pulverising for producing dustable powders. After this, the product is sent to blending machine where the blending of products take place and final product is produced. After Quality checking, if the finished products meets with the ISI Standard, the same is transferred to the stocking bags for packing through automatic machine. The finished product is sent to storage godown for dispatch.



## FLOW CHART FOR WETABLE POWDER FORMULATION

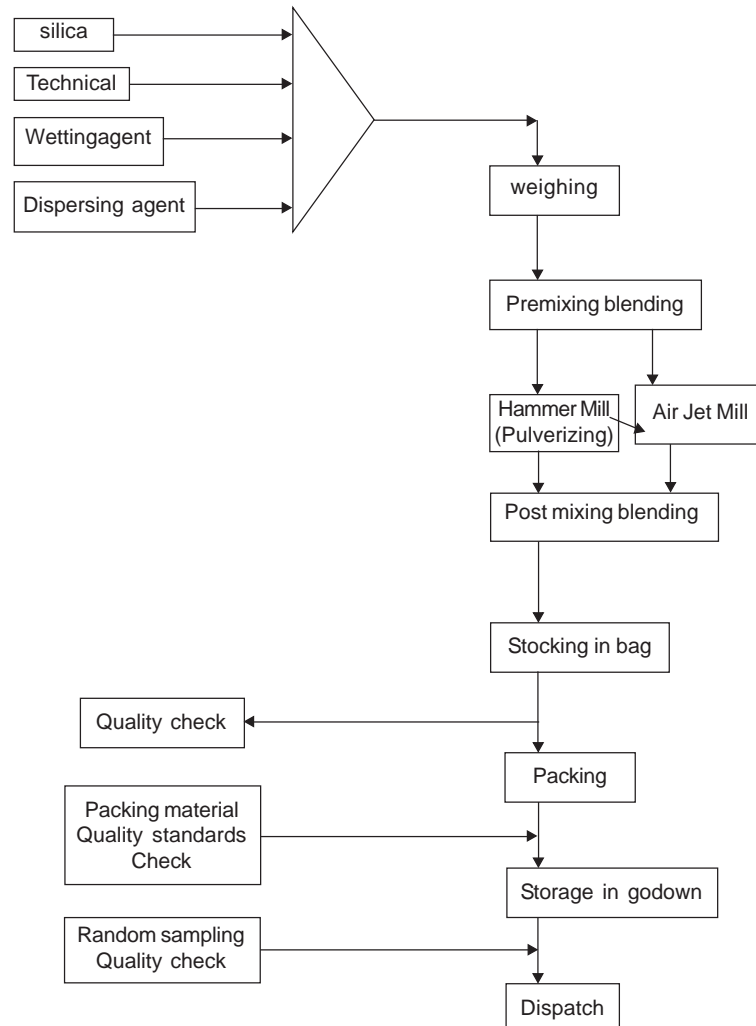

### Granules

The plant and machinery required for granule manufacturing is granule plant and Coated granule mill. It is a completely automated plant where in the raw materials is fed and we get the finished product after passing through various processes shown in the flow chart above. In granule manufacturing plant, each raw material is weighed and fed into the mixing mill as per BIS standard. In the mixing mill all the raw materials are mixed and finished granule is produced. After Quality checking, if the finished granules meet with the ISI Standard, the same is transferred to the storage tank for packing. The finished product is sent to storage godown for dispatch.

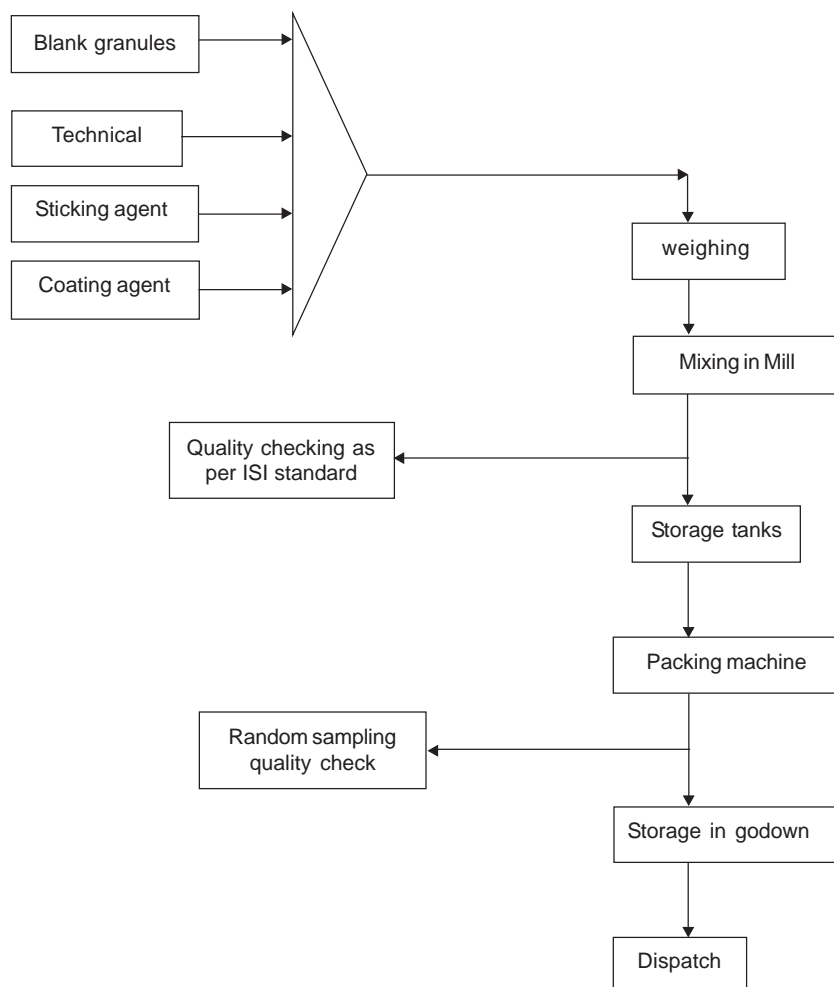
**FLOW CHART FOR GRANULE****Formulations:**

For the manufacturing of the EC formulation, raw materials are mixed in the kettle after weighing. The product is checked for quality standards. If product meet the BIS specifications, it is sent for filtration process. The finished product is stored in intermediate tank. From the intermediate tank these products are sent for packaging. The packed material is sent to storage godown for dispatch.

**Liquids/Emulsifiable concentrates:**

The process involved in the formulation of pesticides can be described as follows:

1. In the first step, the technical grade pesticides, solvents, emulsifiers and other ingredients are weighed based on the batch size that is to be formulated.
2. The materials weighed in step one are directly transferred from the drum/storage tanks to a stainless steel formulation tank, which is then mixed and stirred for a period of four hours to get the desired formulation.
3. Once the desired formulation is ready, samples are drawn from the tank for analysis by the QCD.
4. The QCD gives an analytical report confirming that the products produced meet all specifications as set by Bureau of Indian Standards
5. After which the material in the tank is passed via a filter to the Auto Filling Machine and onto the packing line.
6. The products are then packed in various types of containers such as HDPE, Tin, and Aluminium etc. as per the required guidelines.



## FLOW CHART FOR E.C. FORMULATION

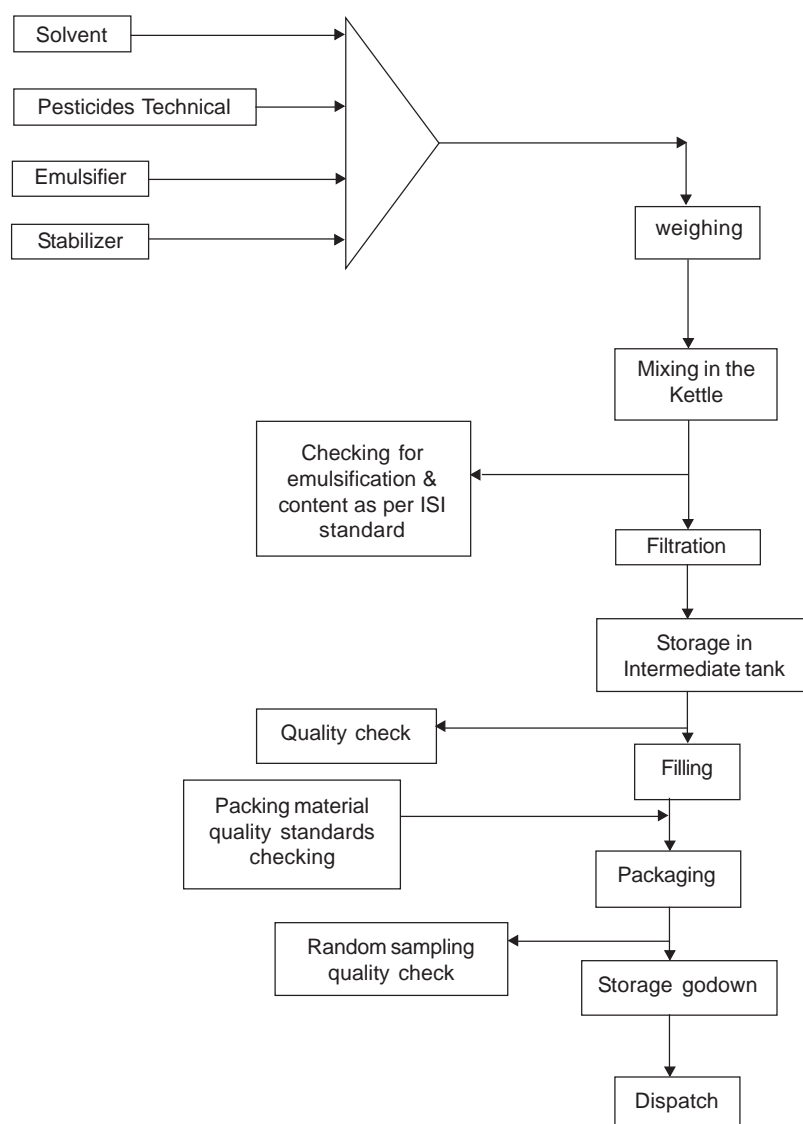

### Quality control

We carry out Quality Control at each stage of production. The quality of input is tested and recorded for the future reference. Based on the input quality the finer adjustment is done manufacturing process to maintain the quality and consistency of end product. The semi finished product is tested for quality and consistency. If there is any deviation from accepted norm the whole batch is reprocessed. Further before the end product is sent for the packing the finished product is tested for quality. If the finished product meets the quality norms then it is sent to the packaging.

### Packaging:

We pack our product in various size depending as per the norms of the insecticides act. The granules are packed in 1kg, 5 Kg, 25 Kg, the EC are packed in 50ml, 100ml, 200ml, 250ml 500ml, 1lt, 5 ltr, 10lt, 20lt packs depending on the products. We use various packaging material including HDPE Bottle of various sizes, Aluminum bottle, Plastic packaging (including the water soluble plastic), Jar, Drums, cartons, bags etc. The finished product is packed in suitable packaging material in suitable quality for the transportation. The packed product passes through the quality checks and send to warehouse before transportation after the getting the clearance of the QC manager.

**Infrastructural Facilities:**

Our Company's headquarter is located at 16-130/12, JRD Tata Industrial Estate, Auto Nagar, Kanuru, Vijayawada – 520 007. This office houses the business units and other support functions such as sales, marketing, finance, HR, and Quality control.

The factory is located in an area of 1849.02 sq. yards and with an RCC built up area of about 15,000 sq. ft. In this multi- product plant, the unit is in a position to manufacture Pesticides, Liquid & Powder formulations. The plant has the installed capacities to manufacture the following:

Granular Formulations	1000 MT
Liquids Formulations	1000 KL
Dusts	300 MT

**Capacity Utilisation of CBL for Different Products**

Products	2003-04		2004-05		2005-06		2006-07		2007-08	
	Installed Capacity	Utilisation (%)	Installed Capacity	Utilisation (%)	Installed Capacity	Utilisation (%)	Installed Capacity	Utilisation (%)	Installed Capacity	Utilisation (%)
Emulsified Concentrate (Kiloliters)	1,000	21%	1000	21%	1000	26%	1000	27%	1000	58%
Granules (tonnes)	1,000	6%	1000	30%	1000	45%	1000	10%	1000	3%
Dusts (tonnes)	300	0%	300	10%	300	7%	300	11%	300	21%

**Raw material:**

All the required raw materials are available in local market throughout the year. The lead-time varies from 15 to 30 days. Major raw materials are Technicals like CHLORPYRIPHOS-20% EC, MONOCROTOPHOS-36% SL, ACEPHATE-75%, SP, QUINALPHOS-25% EC, CARBENDAZIM-50% WP and solvents like C9, Cyclohexanon, Aromax, Methyl Perolidine and emulsifiers like UNITOX 33RN, UNITOX 60RA, CRES 40X, SC793, CRESLOX SC794, UNITOX-CFN, AGRIMAR VA6, BENTONITE GRANULES; SILICA etc.,.

**Power:**

Our Company has sanction of power of about 70 KVA, which is adequate for its existing set of machinery. It has sufficient installed capacity and does not require any increase in the capacity to achieve its targeted sales. Power supply is fairly regular; nevertheless, our Company has installed a D.G .set of 32 KVA capacity to take care of the essential production in case of need.

**Water requirement:**

We do not require water for our manufacturing process except for cleaning process. Factory being located in a well developed industrial estate, water supply is smooth and assured. Our Company has sufficient water connections to accommodate the increased production facilities

**Environment aspect:**

We have taken necessary precautions as desired by Andhra Pradesh Pollution Control Board to keep the pollution levels within purview of norms.

**Fuel:**

We do not require fuel except for the generation of power during the power failures.

**Technology**

We do not have any technology agreement for the current products as the technology used for the manufacturing of current product is readily available. We have semi liquid filling Lines, granule sections for manufacturing & packing.



## Research and Development

Our focus area for R&D are identifying and manufacturing high value added, developing complex new molecules for introduction in generic market. We also focus on development of eco friendly formulations like Soluble Concentrates (SCs), Emulsion in Water (EWs) , Wettable Dispersible Granules( WDGs) etc.

### Manpower Availability:

Our Company at present has 37 permanent employees. The details of the same are as under:

Category	Present	Proposed	Total
Permanent	30	10	40
Trainee	23	50	73
Casual	30	80	110
Contract employee	Nil	Nil	Nil
<b>Total</b>	<b>83</b>	<b>140</b>	<b>223</b>

Vijayawada being a well developed Industrial area has abundant skilled & unskilled labourers who are easily available. Our Company does not foresee any problem in recruiting additional manpower.

### Intellectual Properties:

Our Company has registered the following trademarks with the Trade Marks Registry, Mumbai.

No.	Trade Mark No.	Trade Mark	Class
1	10082"5	"CHEMINOCEL"	1
2	11183"3	"CONTACT"	5

### Immovable Properties of the Company:

#### Our Company owns the following properties:

- Freehold Land admeasuring 2811.36 Square Yards. at No.183/1, Kanura Gram Panchayat Board, Penamaluru Mandal, Vijayawada, Krishna District.
- Freehold Land admeasuring 2260.40 Sq Yards with a constructed area of 5500 sq. feet shed located at plot no.260 A, Kondapalli Industrial Estate, Kondapalli, near Vijayawada.

Our Company has not purchased any property in the past two years in which any Directors or Promoters have any direct or indirect interest in any payment made thereof.

**Competition:** The total market size of the pesticides is estimated at Rs.1,200 Crores in A.P. At present, pesticides are being manufactured by few companies both in the organized & unorganized sector. Major players in the organized sector are UPL, Rallis India Ltd., Hyderabad Chemicals, Bayer Crop Science, Syngenta, Cheminova, Nagarjuna Agri Chem etc. Our Company has a established network of distributors, dealers and retailers, which is a pre-requisite to survive in this sector.

### HR POLICIES OF OUR COMPANY

Our Company has aligned its HR policy with a strategy of sustaining a Leader in Agriculture Formulations and Bio Diesel business. The HR policy aims to enable scalability of its business and processes, simultaneously achieving a high level of ownership and involvement in employees. The HR policy is built around the core values and beliefs of:

- Trust and faith
- Flexibility
- Open culture
- Development of employees being the prime responsibility at our Company level
- Concern for individuals



Initiatives, policies and procedures, are evolved through a consultative process with employees. These have helped create a non-hierarchical, flexible and informal work environment.

The key elements of the HR policy are:

### **Recruitment**

The aim is to attract the best available talent and effectively deploy resources to meet the business requirements. The recruitment sources targeted include a mix of referenced applications and recruitment through advertisements and placement agencies.

### **Training and development**

All new recruits are inducted through a structured training programme involving technical training by a qualified HR team & technical team. The HR policy provides for a minimum 3 days training per year for all employees. Non-executive employees are trained in personal and professional effectiveness, engineers in effective communication skills and front line executives in effective business presentation. Executive development courses are held for staff with supervisory responsibilities. Managerial employees undergo training for management, development and project management skills. Senior managers are also sponsored for advanced management development programmes in leading training institutions in India.

### **Employee evaluation**

Employee evaluation is used as a tool for managing performance planning and motivating, evaluating and enhancing the performance of employees to achieve organizational goals. Performance management seeks to establish and maintain an environment that supports business processes and ensures that employee performance is evaluated against the achievement of objectives aligned to the goals. All employees are provided with an opportunity to discuss their performance, plan their development and submit self-appraisals. Performance appraisals are carried out annually. Performance ratings are discussed with the employee and feedback is given in a very constructive manner. The goals for the next period and the factors that facilitate and inhibit their achievement are discussed.

### **Incentive policy**

Our Company is developing an Incentive policy with the aim to provide higher flexibility and incorporate the best industry practices. The remuneration package consists of fixed and variable components fixed component is based on a cost-to-company structure and is made up of two major components - basic pay and allowances. Variable component is determined based on the performance of the individual, and SBU Performance.

### **Retention**

Our Company endeavors to provide its employees with a challenging work environment aimed at developing individual potential and providing multiple opportunities for growth and fulfillment.

### **BIO DIESEL UNIT:**

Our pesticide business is seasonal to a certain extent. The business is also dependent on uncertainties like dry spells, floods, pest incidents etc. To mitigate the impact of seasonality on our Company financials and to ensure a consistent source of revenue, our Company intends to diversify its operations. Given the huge potential in the Bio-diesel industry and the support lent by the government, our Company has planned to make a foray into the Bio-diesel industry. Our Company as a step towards this direction, has purchased land admeasuring 2260.40 Sq Yards or 1889.98 Sq Metres with 5500 Sq Feet built up industrial shed for setting up its proposed bio-diesel unit. Our Company plans to set up a Bio-diesel manufacturing unit having a capacity of 20 TPD of 3 shifts. Bio-diesel segment has huge potentials both in terms of revenue and profit margin. This would boost our Company profitability and presence in the market. This would help our Company to contribute to the economy by using the waste land and providing agricultural employment.

### **LOCATION OF THE PLANT:**

The proposed manufacturing facility for manufacture of bio diesel is situated at Plot No. 260 A, Industrial Development Area, Kondapally, Krishna Dist, Andhra Pradesh. Details of the facilities including address, area, etc. are given under the heading 'Location & Facilities' in section titled objects of the issue starting from page no.32 of this Prospectus. The processing plant is designed to have installed capacity of 20 TPD of 3 shifts i.e. 6000 tonnes per annum for 300 working days, of bio-diesel production at about 30% yield of input of 20000 tonnes of oil seeds of *Jatropha Curcas*.





## PLANT, MACHINERY, TECHNOLOGY, PROCESSES ETC:

The list of plant and machinery and other equipment required for the Project and the related details are given above in the section entitled 'Objects of the Issue'.

## INFRASTRUCTURE FACILITIES:

### a) Requirement of power and its arrangements:

Uninterrupted power, stable voltage, minimum transmission power line and minimum rate of electricity charges are the main requirements for the efficient running of the Bio Diesel processing unit. Our Company shall apply for a power connection of 125 KVA, which is sufficient for the operation of machines. Our Company will provide for a new D.G. set of 125 KVA as a stand by arrangement..

### b) Requirement of water

The Biodiesel production unit consumes 50 m<sup>3</sup>/ton of water. Water is sufficiently available around the proposed location from ground water

### c) Manpower

Category	Present	Proposed	Total
Permanent	0	7	7
Trainee	0	3	3
Casual	0	27	27
Contract employee	0	0	0
<b>Total</b>	<b>0</b>	<b>37</b>	<b>37</b>

Our Company already has most of the key employees required for managing the proposed project operations. It will be recruiting the additional manpower as listed above in due course. Vijayawada being a well developed Industrial area has abundant skilled & unskilled labourers who are easily available. Our Company does not foresee any problem in recruiting additional manpower.

### d) Raw material

For production of bio diesel at installed capacity, our Company would require 20000 tons per annum of non edible oil. Our Company already has the following arrangements for supply of raw material in place:

- Our Company has entered into an agreement with M/s Jetro Petro Biotech Private Limited our subsidiary company for supply of 1700 tons of Jatropha seeds per month. The company has entered into long term contracts with 179 farmers for growing Jatropha trees in their land aggregating to 2000 acres. This would ensure continuous and adequate supply of jatropha seeds to us .
- The Department of Environment, Forest, Science & Technology, Government of Andhra Pradesh has plans to plant additional 30 - 60 million pongamia trees on degraded soils and waste lands in next few years.
- As per the market survey of Chemical Construction International Pvt. Ltd., 67,000 tons of various non edible vegetable oils / Fatty Acids / Distilled Fatty Acids / Acid oils etc. which indicates substantial availability of raw material in the State of Andhra Pradesh.
- Our Company has been motivating the farmers to go for the plantation of Jatropha

Hence, our Company does not envisage any difficulty in procuring the requisite raw material for its bio diesel project.

## Environmental aspects

The project promotes the use of bio-diesel, which is a renewable fuel. Bio-diesel is comparatively clean, safe, biodegradable and free from sulphur content. Combustion of bio-diesel reduces serious air pollutants such as soot, particulate, carbon monoxide, hydrocarbons and air toxics. In view of the above, bio-diesel can be used as a substitute fuel to petroleum based diesel in transportation vehicles and hence use of bio-diesel is



environmentally safe and reduces air pollution.

Further, substitution of petroleum based diesel with bio-diesel results in reduction of anthropogenic GHG emissions in the transportation sector, since the source of raw materials for bio-diesel manufacturing is Jatropa seeds which continually absorb CO<sub>2</sub> from the atmosphere. In addition, the project activity encourages plantation of new Pongamia and Jatropa trees in wasteland thereby increasing the greenery and making the wastelands more compact. Hence, the project activity results in global environmental benefits by way of mitigation of greenhouse gases.

#### **RESEARCH & DEVELOPMENT:**

Our Company at this point of time has no research and development center for biodiesel.

#### **MARKETING & SELLING ARRANGEMENTS:**

The Ministry of Petroleum and Natural Gas, India had formulated bio diesel purchase policy and as per the policy with effect from 1-1-06 the public sector oil marketing companies shall purchase through select purchase centres ,bio- diesel (B100) which meet the fuel quality standard prescribed in BIS (Bureau of Industrial Standards). Purchase centres have been identified in consultation with oil marketing companies such as IOC,HPC, BPC on basis of testing and blending HSD percent to the extent of 5 percent. As per need more purchase centres would be identified later on. Bio diesel manufacturers should approach the state level coordinator and after assessment of the production capacity and credibility samples would be tested to check if they meet the BIS standards. Ghatkesar (HPC) is the purchase centre for the state of Andhra Pradesh.Registration priority will be given to the producers who propose to use non edible oil and support farming for the same.The Oil marketing companies would fix on a uniform price depending on the market conditions. The uniform price once fixed shall be in operation for six months. The initial purchase price of bio-diesel by the oil marketing companies will be Rs.25 per litre. The registered authorized bio-diesel manufactures shall be required to deliver B100 at the notified purchase centres in calibrated tank trucks of capacity not less than 10 KL. Our Company has already submitted an application to the designated centre expressing interest to supply Bio diesel. After commencement of production our company shall supply bio diesel to the designated centre in terms of the Bio diesel purchase policy of India .

In addition to the above our Company has already received letter showing expression of interest (EOI) from the Indian Railways. Discussions with the Andhra Pradesh State Road Transport Corporation, Vijayawada Municipal Corporation, Andhra Pradesh State Lorry Association and some private Companies in the fields of construction, hospitals, etc. are also in process. These EOIs would be converted into firm Agreements once Bio Diesel production begins.

#### **Transport:**

Our factory is centrally located in the state having excellent rail and road transportation facility to reach any destination within 24 hours in the state.

#### **Governmental Support:**

State Government has announced subsidies for the supply of drip irrigation to jatropa plantations besides supply of seedlings at lowest rates. Governemnt is also coming forward in allotting lands on long lease for developing jatropa plantations. Government is creating enough awareness amongst the farming community for raising jatropa plantations and also with the automobile vehicle users about the damages caused by petrodiesel. This is enough support for ensuring availability of jatropa seeds for manufacturing Biodiesel and also for creating demand amongst the users.

#### **E. PROPERTY**

The details of proposed production facility are provided below

S. No.	Location	Owned/Rented /Contract	Area
01	KONDAPALLY Krishna dist	Own	2260.40 Sq yards or 1889.98 Sq.metres



## F. PURCHASE OF PROPERTY

Except as stated in “Objects of the Issue” in this Offer document and save in respect of the property purchased or acquired or to be purchased or acquired in connection with the business or activities contemplated by the objects of the Issue, there is no property which our Company has purchased or acquired or proposes to purchase or acquire which is to be paid for wholly or partly out of the proceeds of the present Issue or the purchase or acquisition of which has not been completed on the date of this Prospectus, other than property in respect of which the contracts for the purchase or acquisition were entered into in the ordinary course of the business, and the contracts were not entered into in contemplation of the Issue nor is the Issue contemplated in consequence of the contracts; or the amount of the purchase money is not material. Our Company has not purchased any property in which any of its Promoters and/or Directors, have any direct or indirect interest in any payment made thereof.

### Manufacturing process of Bio Diesel :

The dried pods of Jatropha are collected and seeds are separated either manually or mechanically. Seeds are dried under sunlight for 4 days until the moisture is brought to 6-10 per cent before oil extraction..Jatropha seed contains 27-31 per cent extractable oil.

### Production of biodiesel using Jatropha as feedstock

#### I. Pre-treatment

The fruits harvested from the cultivation would be de-hulled to remove the outer cover of the fruit. The pods are collected and seeds are separated mechanically or manually. The seeds are to be dried in sun for four days (6-10%moisture level) and then stored in the silo/warehouse.

#### II. Extraction of crude oil

1. The seed is then crushed in the oil expeller and the oil is pretreated for removing the dusts and other foreign materials. The cake from the oil expeller will contain 10 to 15% of the oil content. This cake will be again treated in the mini-solvent extractor for complete removal of oil from the cake. This oil contains neutral fats (triglycerides), a number of different impurities and lipids (free aliphatic acids, phosphatides, proteins, carbohydrates, mucilaginous substances, waxes, vitamins and pigments).
2. In order to use this oil as a fuel, phosphatides and mucilaginous substances are removed as these accelerate hydrolytic decomposition in stored oil and in ‘conjunction with water, create turbidity and sedimentation. Besides this, other impurities like aliphatic acids, which cause corrosion, lower the flash point and reduce the viscosity of the oil, must also be removed.

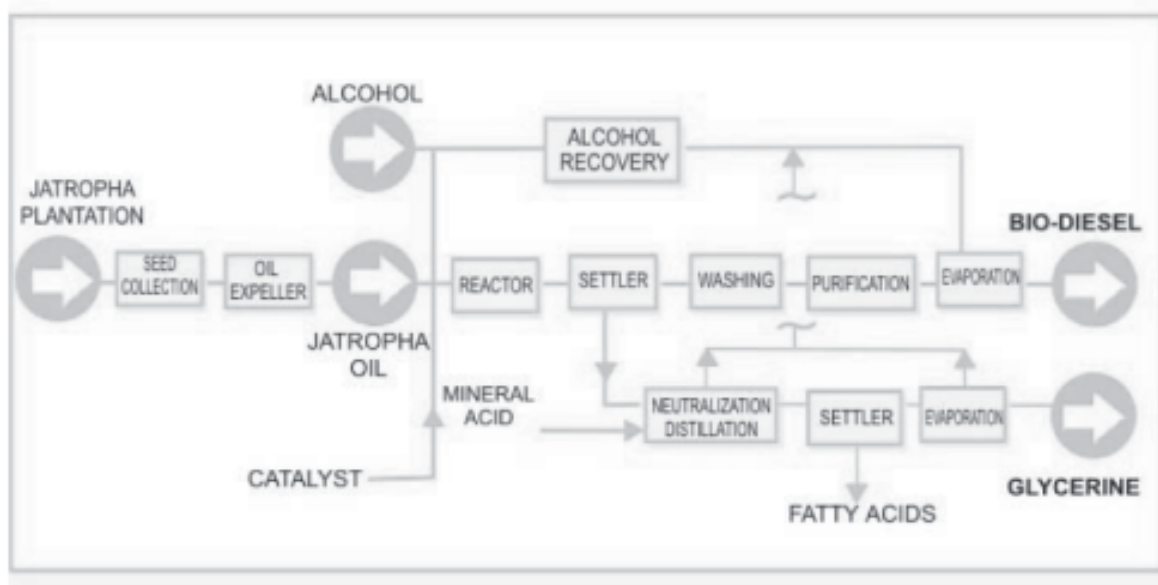





**Source: Planning Commission report**  
**Standards for Biodiesel**

Particulars	ASTM D-6751	IS 15607 : 2005
Density	Not Mentioned	860 - 900 Kg / m <sup>3</sup>
Ester Content	Not Mentioned	96.50%
Flash point (closed cup)	130°C min. (150°C average)	120°C
Water and sediment	0.050% by vol., max.	500 mg / Kg, max.
Kinematic viscosity at 40°C	1.9-6.0 mm <sup>2</sup> /s	2.5-6.0 mm <sup>2</sup> /s
Oxidation Stability	Not Mentioned	6 hours min. at 110°C
Ramsbottom carbon residue, % mass		0.1
Sulfated ash	0.020% by mass, max.	
Sulfur	0.05% by mass, max.	50 mg / Kg max
Copper strip corrosion 3 hrs. 50°C	No. 3 max	Class 1
Catane	47 min.	51 min.
Carbon residue	0.050% by mass, max.	
Acid number, mg KOH/g	0.80 max.	0.50 max.
Methanol or Ethanol	Not Mentioned	0.2 % m/m, max
Free glycerin	0.020 % mass	0.020 % mass
Total glycerine (free glycerine and unconverted glycerides combined)	0.24% by mass, max.	0.25% by mass, max.
Group I Metal (Na+K)	5 mg/Kg, max	5 mg/Kg, max
Group II Metal (Ca+Mg)	Not Mentioned	5 mg/Kg, max
Phosphorus content	0.001 max. % mass	10 mg/Kg, max
Distillation	90% @ 360°C	Not Mentioned

**Source: Planning Commission report**

**Indebtedness**

We are currently enjoying loan/credit facilities from Banks, the details of which are as under:

(Rs. in Lakhs)

Particulars	Bank	Nature of Loan	Sanctioned Amount	Amount Outstanding as on 25.08.2008	Rate of Interest of Loan	Repayment Terms	Securities Offered
Working Capital Facility	Union Bank of India Vijayawada Main Branch	Working Capital Loan	430.00	430.00	12%	On Demand	Hypothecation of stocks, raw materials, finished goods of pesticides fungicides and bio- fertilizers & book debts less than 90 days and personal guarantee of directors
Short Term Loan	Union Bank of India Vijayawada Main Branch		120.00	119.20	12%	On Demand	Same as Above
Term Loan	Kotak Mahendra Bank Ltd., Vijayawada	Term Loan	38.80	34.39	18.46%	Monthly Instalment	First Charge on Kondapalli Site of the Company.
Car Loan	Lakshmi General Finance Limited	Term Loan	3.99	0.32		Monthly Instalment	Hypothecation of car

**Restrictive covenants of the loans agreements:**

Restrictive Covenants of Union Bank of India Loan Agreements are as under.

1. The stocks to remain comprehensively insured from full value with agreed bank clause and original policy to remain with bank.
2. The immovable property taken as collateral security shall be fully insured.
3. Company shall maintain a minimum current ratio of 1.33:1.
4. Our Company shall not without the prior written approval of bank
  - a) effect any change in the capital structure
  - b) formulate any scheme of amalgamation/ reconstruction
  - c) undertake any new project/ expansion/ modernization scheme or make any capital expenditure other than those estimated or projected
  - d) enter into borrowing arrangement either on secured or unsecured basis with any other bank/ FI/ borrower or otherwise.
  - e) Undertake guarantee obligation on behalf of any borrower / organization
  - f) Declare dividends for any year in case the accounts of our Company remain irregular or any other terms & conditions remain uncomplined
  - g) Create charge/ lien/ encumbrance on its asset/ undertakings or any part thereof in favour of any other bank/FI/ borrower/ firm or persons
  - h) Sell, assign, mortgage, alienate or otherwise dispose of any of the assets charged to the bank.
  - i) Enter into contractual obligations of long term nature effecting our Company financially to a significant extent.
  - j) Undertake any activity other than those indicated in the object clause of the memorandum.
  - k) Permit any transfer of the controlling interest or make any drastic change in the management set up.

**Insurance details**

We have insured all moveable and immovable properties of our Company including all stocks, factory premises, plant and machinery. We have taken out the following policies in respect of our properties:

Property Insured	Insurance Company	Sum Insured in Lakhs	Policy No	Premium Paid	Expiry Date
Plant & Machinery (including Storage Tanks)	The New India Assurance Company Ltd	50.00	620800/11/08/11/00000311 dtd 04.06.2008	1,41,770/-	03.06.2009
Furniture & Fittings	The New India Assurance Company Ltd	12.00			
Buildings	The New India Assurance Company Ltd	88.00			
Stocks		365.00			
<b>Total</b>		<b>515.00</b>			

The insurance policies are for period of one year which are renewed on expiration.



## BUSINESS STRATEGY

### PESTICIDES BUSINESS;

The Company operates in a competitive market and aims to be a premier pesticides manufacturing company in the country. The Company believes that there is a tremendous growth opportunity in the agro chemical sector and the domain expertise that the Company has obtained in the past will enable the company to compete effectively in this sector and deliver value proposition to the customers and stakeholders. The Company aims to achieve this by implementing the following strategies:

- **Focusing on sales on a region wise basis**

The pesticides industry in India is region-focused. The Company's strategy is to focus on maximizing net sales realization by focusing on sales of its product on a regional basis. The Company's strategy is to focus on saturating the markets which are close to its plant where it enjoys a relative freight advantage. However the growth in the Indian pesticides markets of Andhra pradesh and neighbouring states has presented a growth opportunity for the Company.

- **Increase in distribution and sales network**

The Company's products are currently marketed through a widespread distribution network comprising of 18 distributors, about 350 dealers and 550 retailers who in turn sell the product to end users such as retailers and farmers. It will continue to focus on building a dedicated and motivated dealer network spread across the state of Andhra pradesh and the neighbouring states a by seeking to add additional dealers to the network and strengthen its relationship with the existing dealers.

- **Increased promotion of Company's brand**

To promote the Company's products and the brand with dealers who are the customers of the Company, the Company organizes meetings with its dealers/customers. The Company also intends to undertake advertising and promotional campaigns in select markets to increase the brand awareness and enhance the understanding of the Company's products. Direct promotional efforts to reach out to contractors and builders would also be done.

- **The Company adopts a multipronged strategy for continuous growth of its business through the following measures:**

- Enhance the quality, design and get up, in accordance with the International Standards.
- Horizontal integration by way of adding new products to the existing products.
- Long term customer relationship and customer satisfaction.
- Need based production.

### BIO-DIESEL:

The first stage of the project is intended primarily to prove the efficiency and benefits of Bio Diesel on the environment, operating costs of the vehicle to the operators, the government, and the general public. Once the users accept the Bio Fuel, as expected, the plant will increase production from 20 tons per day. the expansion will not incur major costs, other than an increase in the working capital and manpower. By the end of the first year of operation, commercialisation of Bio Diesel will be in place.

The Ministry of Petroleum and Natural Gas, India has notified a Bio-diesel Purchase Policy, which provides for purchase of bio-diesel by oil marketing companies at the rate of Rs 25 per litre (inclusive of taxes/duties/transportation cost) with effect from January 1, 2006, at about 20 purchase centers in 12 states. The suppliers should have the capacity to supply minimum 10KL per tanker of bio-diesel meeting prescribed BIS specifications and should be registered with the state level coordinator of oil companies. The blending of bio-diesel at a maximum of 5 percent will be undertaken initially at these 20 centers depending on its availability

- In terms of this policy, our company has submitted expression of interest to the designated purchase centre of Indian Oil Corporation , Andhra Pradesh state for supply of Bio Diesel. After commencement of production our company shall supply bio diesel to the designated centre in terms of the Bio diesel purchase policy of India .



In addition to the above our Company has already received letter showing expression of interest (EOI) from the Indian Railways. Discussions with the Andhra Pradesh State Road Transport Corporation, Vijayawada Municipal Corporation, Andhra Pradesh State Lorry Association and some private Companies in the fields of construction, hospitals, etc. are also in process. These EOIs would be converted into firm Agreements once Bio Diesel production begins.

## **COMPETITORS IN BIO DIESEL MANUFACTURING**

### **LARGE PLANTS**

1. **Naturol BioEnergy Limited**,  
Plot No#1056/1, Road No# 45,  
Jubilee Hills, Hyderabad - 500 033
2. **Southern Online Biotechnologies Limited**,  
Saifabad, Hyderabad..
3. **Garware Polyester Ltd.**,  
Aurangabad Pune Road,  
Waluj, Aurangabad, 431 133.
4. **Nova BioFuels Pvt. Ltd.**,  
Vishnu Carpet Building, Behind ICICI Bank,  
G.T. Road, Panipat, 132 103,
5. **Royal Energy Limited**,  
New Era Mills Compound,  
Mogal Lane, Matunga (W), Mumbai- 400016..

### **SMALL PLANTS**

6. **Mint BioFuels Ltd.**,  
1073/1,2,3, Mutha Road,  
Pirangut, Pune, 412 111,
7. **Aaditya Aromedic & Bio Energies Pvt. Ltd.**,  
Tarsadi-Gujarat,.
8. **Feezol Industries**,  
Shop No. 6, c/o Laxmi Traders,  
opp Madav Ratna-2, Nirmainagar,  
Bhavnagar,.
9. **Gujarat Oleo Chem Ltd.**,  
D-315, Crystal Plaza, Oshiwara Link Road,  
Andheri(w), Mumbai – 400053.
10. **Jain Irrigation Systems Ltd.**,  
Agripark, Jain Hills, PO Box 72,  
Shirsoli Road, Jalgaon-425 001,
11. **India BioDiesel Ltd.**,  
Appt 23/24, 2nd floor,  
8/2, Kiram Shankar Roy Road,  
Kolkata, 700 001..
12. **Grow Diesel Ventures**,  
Gomti Tradelinks, Tikonia Road,  
Haldwani, Distt Nainital, Uttaranchal,.





### 3. KEY INDUSTRY REGULATIONS AND POLICIES

*The following description is a summary of the relevant regulations and policies as prescribed by the Government of India. The summary of regulations set out below is not exhaustive, and is only intended to provide general information to the investors and is neither designed nor intended to be a substitute for professional legal advice*

#### i. For Agro Chemical Business:

##### Environmental Regulations

We have to comply with the provisions of the Environment Protection Act, 1986, Water (Prevention and Control of Pollution) Act, 1974, the Air (Prevention and Control of Pollution) Act, 1981 and the Hazardous Waste (Management and Handling) Rules, 1989. Entrepreneurs are required to obtain statutory clearances relating to pollution control and environment for setting up an industrial project.

A Notification (SO 60(E) dated 27.1.94) issued under The Environment (Protection) Act, 1986 has listed 30 projects in respect of which environmental clearance needs to be obtained from the Ministry of Environment, Government of India. This list includes petrochemical complexes, petroleum refineries, cement, thermal power plants, bulk drugs, chemicals, fertilizers, dyes and paper.

In addition to the above, there are certain other acts and legislations that are applicable to our industry and they are as under:

#### FACTORY RELATED ACT(S)/REGULATION(S)

##### 1. The Insecticides Act, 1968

The provisions of the Insecticides Act, 1968 provides that the act shall be applicable on any process or part of a process which is involved in making, altering, finishing, packing, labeling, breaking up or otherwise treating or adopting any insecticide with a view to its sale, distribution or use but it does not include the packing or breaking up of any insecticide in the ordinary course of retail business. The Act provides that any person desiring to import or manufacture any insecticide may apply to the Registration Committee for the registration of such insecticide and there shall be separate application for each such insecticide.

This Act also provides that any person desiring to manufacture or to sell, stock or exhibit for sale or distribute any insecticide, [or to undertake commercial pest control operations with the use of any insecticide] may make an application to the licensing officer for the grant of a License.

##### 2. Factories Act, 1948

The said act is applicable on establishments employing 10 or more worker. As per the requirement under the Act, Companies have to apply to the Chief Inspector of Factories for certificate of stability, before any premises of a factory are constructed, reconstructed or extended and are used as a factory. The provisions of the Factories Act, 1948 further provides that before the occupier occupies or uses any premises as a factory, he has to inform Chief Inspector of Factories as to certain particulars of the factory, its occupier and its manager etc

##### 3. The Petroleum Act, 1934

In accordance with the provisions of the Petroleum Act, 1934, anyone importing, transporting or storing any petroleum has to take License from Central Government and has to comply all such rules as specified under the Act. Rules laid down by Central Government prescribe the place of import, period within which license shall be taken and regulates the transport of petroleum etc.

##### 4. The Air (Prevention & Control of Pollution) Act, 1981

The provisions of the Air (Prevention & Control of Pollution) Act, 1981 provides that no person operating any industrial plant, in any air pollution control area shall discharge or cause or permit to be discharged the emission of any air pollution in excess of the standards laid down by the state board. Further as per the provisions of the said act, no person shall, without the previous consent of the State Board, establish or operate any industrial plant in an air pollution control area.

**5. The Water (Prevention & Control of Pollution) Act, 1974;**

The provisions of the Water (Prevention & Control of Pollution) Act, 1974 provides that no person shall without the previous consent to establish or take any step to establish any industry, operation or process or any treatment and disposal system for any extension or addition thereto, which is likely to discharge sewage or trade effluent into a stream or well or sewer or on land or bring into use any new or altered outlet for the discharge of sewage or begin to make any new discharge of sewage.

**6. The Manufacture, Storage & Import of Hazardous Chemicals Rules, 1989**

The Rules are applicable on every industry which is carrying the activity which involves or likely to involve one or more of hazardous chemicals and includes on-site storage or on-site transport which is associated with that operation or process or isolated storage or pipeline and accordingly the Rules are applicable on our Company. As per the said rules, an occupier of the industry shall undertake to identify the major accident hazards and also specify the steps initiated to prevent such major accidents and limit their consequences to persons and the environment.

**7. Hazardous Waste (Management and Handling) Rules, 1989;**

Every occupier and the operator who is involved in handling of hazardous waste shall be responsible for proper collection, reception, treatment, storage and disposal of hazardous wastes. The occupier, who intends to get his hazardous waste treated by the operator of a facility, shall give, to the operator, such information as may be specified by the State Pollution Control Board. It shall be the responsibility of the occupier and the operator of a facility, to take all steps to ensure that the wastes are properly handled, and disposed of without any adverse effects to the environment

**8. The Explosives Act, 1884;**

This is a comprehensive law which regulates the manufacture, possession, sale, transportation, exportation and importation of explosives. As per the definition of 'explosives' under the Act, any substance, whether a single chemical compound or a mixture of substances, whether solid or liquid or gaseous, used or manufactured with a view to produce a practical effect by explosion or pyrotechnic effect shall fall under the Act. The Act requires for the licensing for the manufacture, possession, use, sale, transport and Importation of explosives.

**ii. For Bio Diesel Activity :****BIO DIESEL PURCHASE POLICY**

Bio-diesel can be manufactured only by authorised manufactures that are certified authorised and registered. The bio diesel purchase centres should be equipped with minimum testing facilities. The salient features of the policy introduced by the Ministry of Petroleum and Natural Gas, Government of India as follows.

1. With effect from 1-1-06 the public sector oil marketing companies shall purchase through select purchase centres, bio- diesel (B100) which meet the fuel quality standard prescribed in BIS (Bureau of industrial standards).
2. Purchase centres have been identified in consultation with oil marketing companies such as IOC, HPC, BPC on basis of testing and blending HSD percent to the extent of 5 percent. As per need more purchase centres would be identified later on.
3. Interested Bio diesel manufacturers should approach the state level coordinator and after assessment of the production capacity and credibility samples would be tested to check if they meet the BIS standards. Ghatkesar (HPC) is the purchase centre for the state of Andhra Pradesh.
4. Registration is revalidated every year.
5. Registration priority will be given to the producers who propose to use non edible oil and support farming for the same.
6. The Oil marketing companies would fix on a uniform price depending on the market conditions. The uniform price once fixed shall be in operation for six months.



7. The initial purchase price of bio-diesel by the oil marketing companies will be Rs.25/- per litre. The registered authorized bio-diesel manufactures shall be required to deliver B100 at the notified purchase centres in calibrated tank trucks of capacity not less than 10 KL.
8. All the expenses related to testing of the bio-diesel for acceptance of the consignment shall be borne by the oil marketing companies for the following qualities:
  - Density@ 15 degree C.
  - Kinematic Viscosity@40 degree C.
  - Flash Point
  - Water Content
  - Copper corrosion, and
  - Acid value.

Apart from the regulations mentioned above the other regulations involved are Value Added Tax Registration, Excise Registration, Andhra Pradesh Pollution Control Board are also applicable to our Company.



#### 4. HISTORY AND CERTAIN CORPORATE MATTERS

Chemcel Bio-Tech Limited was incorporated as “Chemcel Products Limited” on September 29, 1995 in the State of Andhra Pradesh vide Registration No. 01-21888 under the Companies Act, 1956 and obtained certificate for commencement of business on October 27, 1995. The registered office of our Company was shifted from Plot No. E-32, 100 Feet Road, Auto Nagar, Vijayawada - 7 to the present address w.e.f. February 17, 1998. The name of our Company was changed from Chemcel Products Limited to Chemcel Bio-Tech Limited w.e.f. 4th January, 2001.

Our Company has been promoted by Mr. K Balakrishna Rao, Mr. K T Vijaya Kumar and Mr. K.C.S Prasad with an objective to manufacture Agrochemicals and is now diversifying into the manufacturing of bio-diesel also.

Our Company’s main products are in three forms viz., Liquids, granules and dusts. Individual capacities of these products are as under:

- Liquids 1000 KL/per year
- Granules 1000 MT/per year
- Dusts 300 MT/per year

Our Company has registration with Central Insecticides Board for manufacturing 34 pesticides products, of which our Company is currently manufacturing 17 products.

Our Company has been predominantly concentrating in coastal districts of Andhra Pradesh, where paddy is grown extensively. Over a period, our Company has developed dedicated network of authorised direct dealers, retailers and distributors across 5 districts of Andhra Pradesh.

##### Major Events in the history of our Company

Month	Year	Events
September	1995	Company was incorporated with the name of ‘Chemcel Products Limited’
September	1996	Commenced production with few generic molecules like Monocrotophos, Chloropyriphos, Endosulfan, Quinalphos, Acephate, Phorate and later on synthetic pyrethroids like Cypermethrin & Fenvalerates
May	1998	Company started own production and acquired own property to equip with production facilities; quality control lab; storage of stocks
January	2001	The name of Company was changed to ‘ Chemcel Biotech Limited’
June	2002	Commenced production of specialty molecules like Imidacloprid, Hexaconazole, Tricyclazole apart from me-too molecules of Carbendazim, LambdaCyhalothrin and Bio Products like Amino Acid formulations
April	2004	Company was awarded ‘BEST ENTREPRENEUR AWARD’ for the year 2003-2004 by JRD Tata Industrial Estate
Mar	2006	Pilot Plant of Bio-diesel Manufacturing Unit set up at existing factory; conducted Test Trial of production
August	2006	Company has been selected by Sub-committee (Taskforce on Bio-Diesel) as one of the entrepreneurs for public-private partnership to promote Bio-Diesel Cultivation in the State of Andhra Pradesh. (Vide Letter dated 28.08.2006, Letter No. 79/RS.III/A-1/2004-11 issued by Government of Andhra Pradesh, Rain Shadow Areas Development (RS.III/TA) Department)



### Change in the Registered Office address

Previous Address	New Address	Reason for change	Date of Change
Plot No. E-32, 100 Feet Road, Auto Nagar, Vijayawada-7	16-130/12, JRD Tata Industrial Estate, Auto Nagar, Kanuru, Vijayawada-520 007	Requirement of more office space.	February 17, 1998

### Main objects of our Company

The Objects Clause of the Memorandum of Association of our Company enables it to undertake its present and proposed activities. The objects that permit our Company's main operations are:

- To manufacture, process, refine, buy, sell, import, export and generally deal in the kinds and description of pesticide technicals, Pesticides formulations, insecticides, fungicides, we decides and remedies of all kinds for agriculture or for animals, whether produced from vegetable or animal matter or by any other chemical process, fertilizers, manures, agro chemicals and compounds thereof.
- To manufacture, import, export, buy sell and deal in all raw materials and other substances used in the manufacture of production of any of the above product.
- To design, manufacture, buy, sell and generally deal in agricultural equipment, such as sprayers, blowers, mixture agitators, steel ploughs, disc harrowers, levelers and other mechanically or electrically operated agricultural implements.
- To carry on the business of Manufacturing, Processing and Selling of Edible and Non Edible Seed Extractions and further processing Bio-Diesel or any such essentials.
- To import or Purchase any oil and process, resale, Manufacture as Bio-Diesel and any such products.

### Changes in the Memorandum and Articles of Association of our Company since incorporation

Particulars	Date of meeting	Type of meeting
Company's name was changed from "CHEMCEL PRODUCTS LIMITED" to "CHEMCEL BIO-TECH LIMITED"	Augus 08, 2000	AGM
Increase in Authorised Capital from 5,00,000 equity shares of Rs.10/- each to 12,00,000 Equity shares of Rs.10/- each	April 30,2003	EGM
Addition of following clauses in the main objects of our Company "To carry on the business of Manufacturing, processing and Selling of Edible and Non Edible Seed Extractions and further processing Bio-Diesel or any such essentials."	April 04, 2005	EGM
"To import or purchase any oil and process, resale, Manufacture as Bio-Diesel and any such Products."		
Alteration of Articles of association as follows :- Addition of Article 18(A), 13(A),13(B) 15(A), And 61(A) Replacing the Article 18,34,29 19 and 136	December 29, 2005	EGM
Increase in Authorised Capital from 12,00,000 equity shares of Rs.10/- each to 2,62,00,000 Equity shares of Rs.10/- each	December 29, 2005	EGM
Increase in Authorised Capital from 2,62,00,000 Equity Shares of Rs.10/- each to 3,00,00,000 Equity Shares of Rs.10/- each	November 15, 2006	EGM

**Subsidiaries of our Company:****Jetro Petro Biotech Private Limited**

M/s Jetro Petro Biotech Private Limited, our subsidiary company, was incorporated with Registrar of Companies A.P. Hyderabad on 24.05.2007 and allotted CIN No: CIN U 24211AP2007PTC054119. Jetro Petro Biotech Private Limited is a private limited company incorporated under the Companies Act, 1956 on May 24, 2007 under CIN U24211AP2007PTC054119. The issued subscribed and paid up capital of the Subsidiary is 1,00,000 equity share of Rs. 10 each. The registered office of the company is situated at 29/36/37 Ground floor, Ammana Estate, Museum Road, Vijaywada.

The main object of this Company is to carry on the business as procurement of jatropha seeds from farmers and to supply jetropha seeds useful for extraction of biodiesel. At present, the company with the help of advance given to them by our company to the extent of Rs Rs.539.41 lakhs has entered into long term contracts with 179 farmers in Andhra Pradesh to cultivate and grow jetropha plants, in about 2200 acres, so that the seeds can be collected from farmers to facilitate uninterrupted supply of Jatropha seeds for purpose of extraction of Bio diesel.

**Board of Directors****Director's Name****Designation**

P. L. NARASIMHA MURTHY

MANAGING DIRECTOR

Y V RAMANA RAO

DIRECTOR

**Promoters and their Profile:****P.L NARASIMHA MURTHY:**

Mr.P L Narasimha Murthy, aged 35 years and graduate in commerce. He has 15 years of rich experience in auditing of financial accounts with Audit companies besides experience in procurement of seeds and good rapport with farmers. He is the Managing director of our subsidiary company.

**Y V RAMANA RAO :**

Mr Y V Ramana Rao, aged 40 years and graduate in Arts. He has wide range of experience in business contacts, farmer contacts and in marketing fields. He is the Director of our subsidiary company.

**Shareholding Pattern as on 28.11.2007:**

Name of share holders	No of Shares held	% Holding
P.L.NARASIMHA MURTHY	10000	20%
Y V RAMANA RAO	10000	20%
CHEMCEL BIOTECH LTD	30000	60%
Total	50000	100%

**There are no defaults in meeting any statutory/bank/institutional dues.**

**No proceedings have been initiated for economic offences against the Company, its promoters or directors.**

M/s Jetro Petro Biotech Private Limited is an unlisted company and has not made any right issue or public issue in preceding three years.

It has not become sick company under the meaning of SICA and is not under winding.

**Transactions between Chemcel Biotech Ltd and M/s Jetro Petro Biotech Private Limited**

Our Company has provided advance of Rs.539.41 lakhs to the subsidiary company M/s Jetro Petro Biotech Private Limited for taking long term contracts with the farmers in Andhra Pradesh to grow Jetropha plants so that their seeds can be collected and supplied to our company for extraction of Biodiesel. Consequently our subsidiary company has entered with various farmers in Andhra Pradesh to cultivate and grow Jetropha plants and the activity is in process.

**Financial Performance :**

Particulars	For the Year ended 31.03.08 (Rs. In Lakhs)
Share Capital	5.00
Reserves (Excluding Revaluation Reserve)	(1.97)
Less : Miscellaneous Expenses ( to the extent of not written off or adjusted)	(0.43)
Net Worth	<b>2.60</b>
Total Income	<b>0</b>
PBT	(1.98)
EPS (Per Share) (Rs.)	(3.96)
NAV Per Share (Rs.)	5.20

**Shareholders Agreement**

There is no shareholders agreement existing as on date.

**Other Agreements****i) Agreement for supply of raw material**

Our Company has entered into agreement with M/s. Jetro Petro Biotech Private Limited (JPBPL), our subsidiary company, dated May 25, 2007, for the supply of raw materials including Jatropha Seeds, Pongamia, Neem, Palm oil seeds, cotton seeds and all such other kinds of seeds useful for the purpose.

The salient features of the agreement are as follows:

1. The JPBPL will supply to procure and supply to the Company Jatropha seeds, , the main raw material for our proposed bio diesel plant.
2. The duration of this agreement is for Nine years with effect from September 2008.
6. JPBPL has to supply the Jatropha seed exclusively to our Company
7. Either of the parties has the right to cancel the agreement by giving a notice of a minimum of 12 months.

**Strategic Partners**

There is no strategic agreement existing as on date.

**Financial partners**

There are no financial partners.



## 5. MANAGEMENT

Our Company is a professionally managed organization under the control of the Board of Directors.

### Board of Directors of our Company

The Board of Directors of our Company comprises:

Name, Age, Designation and Occupation of the Directors	Address	Appointment in our Company and the date of expiration of current term of office	Other Director -ships	Status
<b>Mr. Kanuparthi Balakrishna Rao</b> S/o Mr K.Krishna Rao Age: 70 years Designation: Chairman Occupation: Business DIN NO. 01628865	101, Sindhoor Apartments, Gayathri Nagar, Vijayawada - 520008	May 01, 2003 to April, 2008	Jetro petro Biotech Private Limited	Chairman & Executive Director
<b>Mr. Kanuparthi Trinatha Vijaya Kumar</b> S/o Mr K.Krishna Rao Age: 51 years Designation: Managing Director Occupation: Business DIN NO 01628916	# 23-12-25/A, Abhuri Vari Street, Satyanarayanapuram, Vijayawada - 520 011	May 01, 2003 to April, 2008	NIL	Managing Director
<b>Mr. Kanuparthi Chandra Shekhar Prasad</b> S/o Mr K.Balakrishna Rao Age: 43 years Designation: Director (Production) Occupation: Business DIN NO 01628889	205, Sindhoor Apartments, Gayathri Nagar, Vijayawada - 520 008.	May 01, 2003 to April, 2008	NIL	Wholetime Director
<b>Mr. Dhulipala Sankar</b> S/o Mr Dhulipala Ramakrishna Rao Age: 61Years Designation: Director Occupation: Business DIN NO 01711075	Door No. 26-13-52, Sanyasiraju Street, Gandhinagar, Vijayawada - 520 003	May 30,2007 Retirement by rotation	NIL	Independent Director
<b>Mr. Polamraju Narasimha Murthy</b> S/o Mr Polamraju Sri Rama Murthy Age: 60 Years Designation: Director Occupation: Business DIN NO 00973566	Plot No.127, Defence Colony, Sainikpuri, Secunderabad - 500 094	August 1, 2005 Retirement by rotation	NIL	Independent Director
<b>Mr. Koka Shri Hari Rao</b> S/o Mr Koka Visvanatha Rao Age: 66 years Designation: Director Occupation: Business DIN NO. 01782821	Visvantha, Door No.41-1-2/A, Post Office Road, Krishnalanka, Vijayawada - 520 013.	August 1, 2005 Retirement by rotation	NIL	Independent Director





### Brief profile of the Board of Directors

**Mr. Kanuparthi Balakrishna Rao**, aged 70 yrs is a post graduate in Business Management. He started his career with Mysore Fertilizers and worked for more than 20 years and occupied several key posts ranging from finance to Marketing. Later, he joined Coromandal Indag group and was in-charge of Agro chemicals division for Andhra Pradesh. He continued to work here for almost 10 years and resigned from the job in 1994 to start Chemcel. During his stint in Coromandal Indag group, he handled the production of Agro-Chemical Formulations of their Vijayawada Unit and the marketing of Fertilizers and pesticides in the entire Andhra Pradesh.

**Mr. Kanuparthi Trinatha Vijaya Kumar**, aged 51 yrs is a graduate in Commerce and worked with Rallis India Limited in different capacities at Vijayawada for a period of 22 years. He was in-charge of all the marketing activities in Coastal Andhra Pradesh and was directly responsible for sales.

**Mr. Kanuparthi Chandra Shekhar Prasad**, Director (Production) aged 43 yrs holds PG Diploma in Personnel Management. Since the inception of this organization, he is in-charge of Production and Procurement besides General Administration.

**Mr. Dhulipala Sankar**, is an Independent Director of our Company. Aged 61 years, he is an associate of Institute of Chartered Accountants of India. For over 20 years he has worked in Container Accounts department, Finance Division, UAE, Kuwait. Earlier he had been with Shipping Corporation of India, Mumbai for about 6 years. He had also been with Price Water House Peat & Co for about 5 years and Mazagaon Docks Limited, Mumbai for 3 years. He has wide knowledge in Accounting, Taxation, Auditing and Company affairs.

**Mr. Polamraju Narasimha Murthy**, is an Independent Director of our Company. Aged 60 years is a Post Graduate in public Administration, Sugar Technology and is a Qualified in chemical engineering. He has more than 34 years experience in the manufacturing field.

**Mr. Koka Shri Hari Rao** is an Independent Director of our Company. Aged 66 years, he is a Post Graduate, retired as administrative officer from Andhra Pradesh State Meat & Poultry Development Corporation.

### Relationship amongst the Directors

None of the Directors except Mr. Kanuparthi Balakrishna Rao, Mr. K.T. Vijay Kumar and Mr. Kanuparthi Chandra Shekhar Prasad have any family relation between them.

Service contracts entered into with the Whole time Directors does not provide for benefits upon termination of employment

### Borrowing Powers of the Board

The shareholders vide a resolution pursuant to section 293(1) (d) of the Companies Act, 1956 passed at the Annual General Meeting of our Company held on 2nd May 2005, had approved and delegated powers to the Board for borrowing up to a sum of Rs 7.50 Crores apart from temporary loans obtained or to be obtained from Company's bankers in the ordinary course of business notwithstanding that it is over and above the aggregate of the paid-up share capital and free reserves.

### Compensation of Managing Director/Whole time Directors

<b>Name</b>	<b>Mr. Kanuparthi Balakrishna Rao</b>
<b>Designation</b>	Executive Chairman
<b>Period</b>	3 years w.e.f. February 01,2006
<b>Remuneration</b>	i) Salary: Rs. 70,000 per month. ii) Rent free furnished accommodation value not exceeding @15% of the Salary over and above Ten percent of the salary payable by the Executive Director or House Rent Allowance @ 15% of the salary. iii) 1-month salary per annum for self and family iv) For self and family, value not exceeding one-month salary per Annum.



	<ul style="list-style-type: none"> <li>v) Fees of clubs shall be reimbursed subject to a maximum of two clubs. Admission fee or life member fee shall not be reimbursable.</li> <li>vi) Insurance and/or Accident Insurance, premium not to exceed half month basic salary.</li> </ul>
<b>Name</b>	<b>Mr. Kanuparthi Trinatha Vijaya Kumar</b>
Designation	Managing Director
Period	3 years w.e.f. February 01,2006
Remuneration	<ul style="list-style-type: none"> <li>i) Salary Rs. 65,000 /- P.M.</li> <li>ii) Perquisites: In addition to salary Sri. K. T. Vijay Kumar is entitled to the following perquisites, classified into three categories.</li> <li>iii) Rent free furnished accommodation value not exceeding @15% of the Salary over and above Ten percent of the salary payable by the Managing Director or House Rent Allowance @ 15% of the salary.</li> <li>iv) 1-month salary per annum for self and family</li> <li>v) For Self and Family, value not exceeding one-month salary per Annum.</li> <li>vi) Fees of clubs shall be reimbursed subject to a maximum of two clubs. Admission fee or life member fee shall not be reimbursable.</li> <li>vii) Insurance and/or Accident Insurance, Premium not to exceed half month Basic salary.</li> </ul>
<b>Name</b>	<b>Mr. Kanuparthi Chandra Shekhar Prasad</b>
Designation	Director(Production)
Period	3 years w.e.f. February 01,2006
Remuneration	<ul style="list-style-type: none"> <li>i) Salary Rs. 50,000 /- P.M.</li> <li>ii) Perquisites: In addition to salary Mr. Kanuparthi Chandra Shekhar Prasad is entitled to the following perquisites, classified into three categories.</li> <li>iii) Rent free furnished accommodation value not exceeding @15% of the Salary over and above Ten percent of the salary payable by the K. C. S. Prasad or House Rent Allowance @ 15% of the salary.</li> <li>iv) 1-month salary per annum for self and family</li> <li>v) For Self and Family, value not exceeding one-month salary per Annum.</li> <li>vi) Fees of clubs shall be reimbursed subject to a maximum of two clubs. Admission fee or life member fee shall not be reimbursable.</li> <li>vii) Insurance and/or Accident Insurance, Premium not to exceed half month Basic salary.</li> </ul>

### Corporate Governance

Our Company has complied with SEBI DIP Guidelines in respect to Corporate Governance especially with respect to broad basing its Board of Directors and setting up of necessary committees such as Audit Committee, Shareholders/Investor Grievance Committee and Compensation Committee.

### Board of Directors

The Board of Directors consists of 6 members comprising three Promoters Directors and three non- executive independent directors.



Our Company continues to emphasize on its philosophy of achieving corporate goals through good corporate governance practices. Its belief is that such a philosophy can enable our Company to serve its stakeholders - customers, vendors and shareholders - better, and enhance value through greater transparency, accountability and integrity. Our Company believes in the principles of responsibility and commitment, which ensure a better relationship with shareholders, customers, the government, lenders and the community at large. It also progressive and trustworthy in all its transactions with stakeholders and customers alike. Our Company has duly implemented all relevant provisions of the corporate governance guidelines as suggested by SEBI.

Our Company reliance and belief in corporate governance principles are based on the commitment to enrich our Company with the best management practices and to fulfill our Company vision with attainment of the highest levels of fidelity, accountability and transparency.

## Committees of the Board

### Audit Committee

#### Composition of the Audit Committee:

Name	Designation
Mr. Dhulipala Sankar	Chairman - Independent Director
Mr. Koka Shri Hari Rao	Member - Independent Director
Mr. Polamraju Narasimha Murthy	Member - Independent Director

#### 1. Terms of Reference

The Audit Committee provides the Board with additional assurance as to the adequacy of our Company's internal control systems and financial disclosures. The Audit Committee acts as a link between the Management, Statutory Auditors, Internal Auditors and the Board of Directors. The Composition, powers and functions of the Audit committee meet the requirements of the listing Agreement and Section 292 A of the Companies Act 1956. The broad terms of reference of Audit committee are in the following areas: -

#### 2. The role of the audit committee shall include the following:

- o Oversight of the company's financial reporting process and the disclosure of its financial information to ensure that the financial statement is correct, sufficient and credible.
- Recommending to the Board, the appointment, re-appointment and, if required, the replacement or removal of the statutory auditor and the fixation of audit fees.
- Approval of payment to statutory auditors for any other services rendered by the statutory auditors.
- Reviewing, with the management, the annual financial statements before submission to the board for approval, with particular reference to:
  - o Matters required to be included in the Director's Responsibility Statement to be included in the Board's report in terms of clause (2AA) of section 217 of the Companies Act, 1956
  - o Changes, if any, in accounting policies and practices and reasons for the same
  - o Major accounting entries involving estimates based on the exercise of judgment by management
  - o Significant adjustments made in the financial statements arising out of audit findings
  - o Compliance with listing and other legal requirements relating to financial statements
  - o Disclosure of any related party transactions
  - o Qualifications in the draft audit report.
  - o Reviewing, with the management, the quarterly financial statements before submission to the board for approval



- o Reviewing, with the management, performance of statutory and internal auditors, and adequacy of the internal control systems.
- o Reviewing the adequacy of internal audit function, if any, including the structure of the internal audit department, staffing and seniority of the official heading the department, reporting structure coverage and frequency of internal audit.
- o Discussion with internal auditors any significant findings and follow up there on.
- o Reviewing the findings of any internal investigations by the internal auditors into matters where there is suspected fraud or irregularity or a failure of internal control systems of a material nature and reporting the matter to the board.
- o Discussion with statutory auditors before the audit commences, about the nature and scope of audit as well as post-audit discussion to ascertain any area of concern.
- o To look into the reasons for substantial defaults in the payment to the depositors, debenture holders, shareholders (in case of non payment of declared dividends) and creditors.
- o To review the functioning of the Whistle Blower mechanism, in case the same is existing.
- o Carrying out any other function as is mentioned in the terms of reference of the Audit Committee.

### Remuneration Committee

Our Company has a remuneration committee comprising three members all are Non-Executive and independent directors to decide the remuneration payable to the directors. The composition of the Remuneration Committee are as follows.

Name	Designation
Mr. Dhulipala Sankar	Chairman - - Independent Director
Mr. K. Shri Hari Rao	Member - - Independent Director
P.Narasimha Murthy	Member - - Independent Director

### SHAREHOLDERS AND INVESTOR GRIEVANCES COMMITTEE

As a measure of Good Corporate Governance and to focus on the shareholders grievances and towards strengthening investor relations, an Investor's Grievance Committee has been constituted as sub committee of the Boaa) The functions of the Committee include:

To specifically look into redressing investor's grievances pertaining to

1. Transfer of shares.
2. Non Receipt of Annual Reports, Declared Dividend.
3. Dematerialization of Shares.
4. Replacement of lost/stolen/mutilated share certificates.
5. Non-receipt of rights/bonus/split shares certificates.
6. Non-receipt of Allotment advice / Refund orders.

Any other related issues

#### b) Constitution and Composition

Name	Designation
Mr.K. Shri Hari Rao	Chairman - Independent Director
Mr. K.T.Vijay Kumar	Member - Executive Director
Mr. Kanuparthi Chandra Shekhar Prasad	Member - - Executive Director

**Shares held by Directors as on the date of filing Prospectus with SEBI**

Sl.No.	Name	No. of Shares	% of Shareholding
1.	Mr. K.Balakrishna Rao	7,67,636	7.30
2.	Mr .K. T. Vijay Kumar	29,68,169	28.22
3.	Mr. K.C.S. Prasad	10,92,642	10.39

**Interest of Directors and Promoters.**

All the Director may be deemed to be interested to the extent of remuneration and/or sitting fees payable to them for attending the meeting of the Board or Committee thereof apart from reimbursement of traveling/incidental expenses, if any, as per the Articles of Association of our Company.

The Executive Chairman/Managing Director/Whole-time Director/Directors/Promoters of our Company shall be deemed to be interested to the extent of shares held by them and/or their friends and relatives and which may be allotted to them out of the present issue and are also deemed to be interested to the extent of remuneration and perquisites being drawn by them from our Company .

Except as stated otherwise, in this Prospectus, our Company has not entered into any contract, agreements or arrangements during the preceding two years from the date of the Prospectus in which the directors are interested directly or indirectly and no payments have been made to them in respect of these contracts, agreements or arrangements or are proposed to be made to them.

**Changes in the Board of Directors during the last 3 years**

Name of Director	Date of Appointment	Date of Resignation	Reasons of resignation
Mr.Balusu Kameswara Sharma	-	November 01,2004	Personal
Mr. Marthi Venkata Rama Sastry	October 15,2004	March 31,2005	Personal
Mr. M.V.Sampatha Baba	August 01,2005	Ceased due to death on March 17, 2007	-
Mr.P.Narasimha Murthy	August 01, 2005	-	-
Mr.K.Shri Hari Rao	August 01, 2005	-	-



### Management Organisation Structure

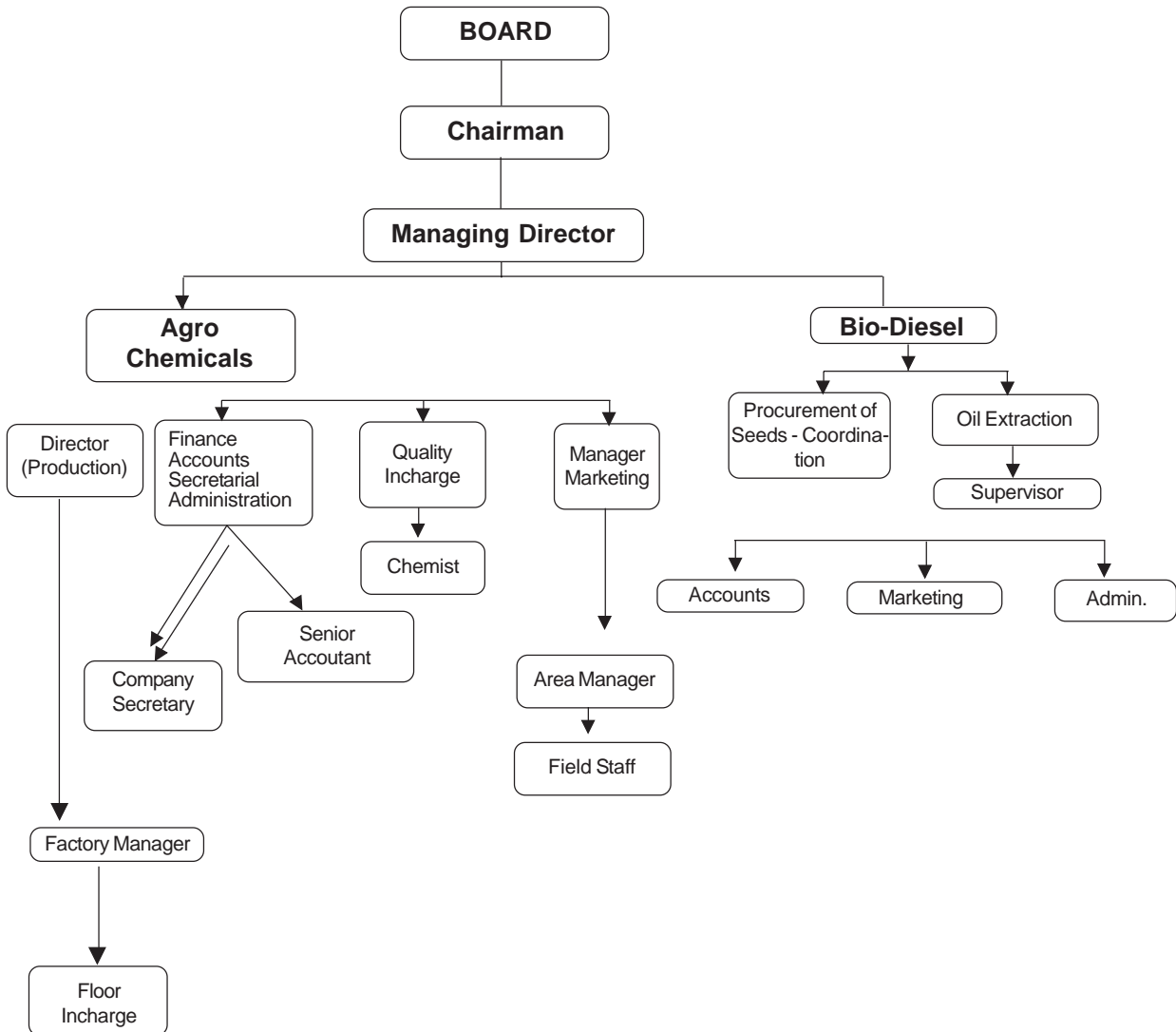

Our Company for its bio diesel project, is assisted by a technical consultant and has a team of technical advisors. The Managing Director of our Company, Mr. K.T. Vijaya Kumar, also devotes a substantial portion of his time to the bio diesel project. Our Company would in due course appoint the requisite personnel for the bio diesel project. The support function personnel within the departments of finance, marketing etc, are also responsible for the bio diesel project.



### Key Managerial Personnel

Our Company's key management team is made up of qualified professionals and experience in their respective fields of expertise. The Managing Director is assisted in their day-to-day responsibilities by a team of professionals as under.

Sr. No.	Name	Age	Designation	Qualification	Exp. (yrs.)	Functional Responsibility	Date of joining	Past Experience
1	Mr Shaik Rahmatullah	69 Yrs	Company Secretary	B.Com (Hons) A.C.S. A.C.I.S (London)	14 Yrs	Incharge of all company law matters & secretarial function.	Jul 21, 2007	Worked for 14 Yrs for Springfields Securities Ltd., U.B.E. Industries; Goldwon Textile Ltd
2	Mr.P.V.S Prasad	45 yrs	Manager-Factory & Quality Control	B.Sc. H.D.C	19 yrs	Head-Production & Quality Control	Jul 01, 1996	
3	Mr.D.Surendra Nath	45 yrs	Manager - Marketing	M.Sc (Agriculture)	11 yrs	Head - Sales & Marketing	Apr 12, 2003	Worked with Godavari Fertilisers and Chemicals for 2 years. Worked with Rallis India Limited for 7 years.
4	Mr.CH.V.Vara Prasada Rao	55 yrs	Manager -Admin	B.Sc.	27 yrs	Administration	Mar 05, 2005	Worked for 26 years with M/s Rallis India Limited.
5	Mr.B Kameswara Rao	37 Yrs	Senior Accountant	C.A (Final); DCA in computers	14 Yrs	Head-Accounts	Jun 07, 2006	Worked in finalization of audits & taxations with Chartered accountants for over 10 yrs
6	Mr.KRaghurama Charyulu	50 yrs	Senior Accountant	B.Com	24 yrs	Accounts Incharge.	Jan 01, 1998	Worked as Accountant for 12 years with Bright Light Carbons Limited. Worked as Accountant for 4 years with Food & Allied products.
7	Mr.K.Srinivasa Rao	39 yrs	Production Officer	Intermediate	13 yrs	Incharge of Production operations	Aug 01, 2002	Worked as production incharge in Bhaskar Agro Chem, for 6 yrs and Phyto Chem, Hyderabad for 7 years

- The persons mentioned above are in the employment of our Company as permanent employees.
- None of the key personnel mentioned above are related to the promoters/Directors of our Company, except Mr.P.V.S Prasad, a chemist in the Company, who is nephew of Mr. Balakrishna Rao / Mr. K.T.Vijaya Kumar.
- No director or member of Senior Management has been selected pursuant to any arrangement/ understanding with major shareholders/customers/suppliers.

**Compensation paid to key managerial personnel for the financial years 2005-06 and 2006-07**

S.No	Key Managerial Staff	Compensation paid	
		2006-2007	2007-08
1	Mr. K. Srinivas Prasad*	375000	150,000
2	Mr. D. Surendra Nath	144720	216,000
3	Mr. K.Srinivas Rao	68400	108,000
4	Mr.B.Kameswar Rao **	88200	169,200
5	Mr.K Raghurama Charyulu	90720	120,960
6	Mr. P. V. S. Prasad	105948	149,148

\*Resigned w.e.f 30.06.2007

\*\* Employed with effect from June 2006

No portion of the compensation was paid pursuant to a bonus or profit sharing plan.

**Changes in key managerial personnel during the preceding three years**

No changes in the key managerial personnel during the last 3 years other than the following

S.No	Name	Appointment/ Resignation	Effect from	Reasons for leaving
1	Mr. Shaik Rahmatullah	Appointed as Company Secretary	July 21, 2007	-
2	MR. K. Srinivasa Prasad	Appointed as a Vice President - Corporate Affairs	June 01, 2006	-
3	MR. K. Srinivasa Prasad	Resigned as Vice President - Corporate Affairs	July 01, 2007	Personal reasons
4	Mr.Kameswara Rao	Appointed as Senior accountant	Jun 07, 2006	-
5	Mr. Ch.V. Varaprasad Rao	Appointed as manager - Admin	Mar 05, 2005	-
6	Mrs. K. Rajyalakshmi	Resigned as Company Secretary	Feb28, 2007	For personal reasons
7	Mr. S. Bhagavan Singh	Resigned as Manager - Production	Oct 31, 2006	For personal reasons
8	Mr. B. Sudhakar	Resigned as DGM- Sales	Oct 31, 2006	For personal reasons

**Shares Held by the Key Managerial Personnel as on March 31, 2008**

SL.No	Name of Key Managerial Personnel	No. Shares	% of pre issue capital
1	Mr. D. Surendranath	100	-
2	Mr. Ch. V. Varaprasad Rao	100	-
3	Mr. B. Kameswara Rao	100	-
4	Mr. K. Raghuramacharyulu	100	-
5	Mr. PVS Prasad	100	-
6	Me. K. Srinivasa Rao	100	-





None of the key managerial personnel hold any shares as at the date of this Prospectus other than the above.

### Manpower

The present and proposed manpower strength of our Company for Agrochemicals and Bio-Diesel:

#### Agrochemicals

Category	Present	Proposed	Total
Permanent	37	10	47
Trainee	23	50	73
Casual	30	80	110
Contract employee	Nil	Nil	Nil
<b>Total</b>	<b>90</b>	<b>140</b>	<b>230</b>

#### Bio-Diesel

Category	Present	Proposed	Total
Permanent	0	7	7
Trainee	0	3	3
Casual	0	27	27
Contract employee	0	0	0
<b>Total</b>	<b>0</b>	<b>37</b>	<b>37</b>

Vijayawada being a well developed Industrial area has abundant skilled & unskilled labourers who are easily available. Our Company does not foresee any problem in recruiting additional manpower.



#### Disclosures Regarding Employees Stock Option Scheme / Employees Stock Purchase Scheme

Till date, our Company has not introduced any Employees Stock Option Scheme / Employees Stock Purchase Scheme, as required by the Guidelines or Regulations of SEBI relating to Employee Stock Option Scheme and Employee Stock Purchase Scheme.

#### Payment of Benefit to Promoters and Officers of our Company

Save as stated in page no.107 of Auditors report in this Prospectus, no amount or benefit has been paid or given to our Company's officers since the incorporation of our Company nor is intended to be paid or given to any officer of our Company except their normal remuneration and/or reimbursement for services as Directors, Officers or Employees of our Company or otherwise in accordance with Law.

**6. PROMOTERS**

	<b>Mr. Kanuparthi Balakrishna Rao</b> aged 70 yrs is a post graduate in Business Management. He started his career with Mysore Fertilizers and worked for more than 20 years and occupied several key posts ranging from finance to Marketing. Later, he joined Coromandal Indag group and was in-charge of Agro Chemicals division for Andhra Pradesh. He continued to work here for almost 10 years In 1995 he started Chemcel. During his stint in Coromandal Indag he handled the production of Agro-Chemical Formulations and the marketing of Fertilizers and pesticides in the entire Andhra Pradesh.
	<b>Mr. Kanuparthi Trinatha Vijaya Kumar</b> , aged 51 yrs is a graduate in Commerce and worked with M/s. Rallis India Limited in different capacities at Vijayawada for a period of 22 years. He was in-charge of all the marketing activities in Coastal Andhra Pradesh and was directly responsible for sales.
	<b>Mr. Kanuparthi Chandra Shekhar Prasad, Director</b> (Production) aged 43 yrs holds PG Diploma in Personnel Management. Since inception of our Company , he is in-charge of Production and Procurement besides General Administration.

<b>Mr. Balakrishna Rao</b>	<b>Mr. Kanuparthi Trinatha</b>	<b>Mr. Kanuparthi Chandra Vijaya Kumar      Shekhar Prasad</b>
Voter ID : NA	Voter ID: AP/13/78/087334	Voter ID: NA
Driving License No: DLRAP016250492003	Driving license No. 16525/VIA/1984	Driving license No. DLRAP016272472004
PAN No: ACRPK6092K	PAN No. : AABHK8356C	PAN No. : ACWPK3509N
Passport No:A6959415	Passport No: NA	Passport No: A1082497
Bank Account No: Union Bank of India, Vijayawada Main Branch,Rishab Towers, 1st Floor, Convent Street, Saving A/c No. 8483.	Bank Account No:Union Bank of India, Vijayawada Main Branch, Rishab Towers, 1st Floor, Convent Street, Saving A/c No.8136.	Bank Account No:Union Bank of India, Vijayawada Main Branch, Rishab Towers, 1st Floor, Convent Street, Saving A/c No. 8488.

We confirm that the PAN, Bank Accounts numbers and Passport Numbers have been submitted to the Stock Exchange on which securities are proposed to be listed.

**Interest of Promoters and Directors**

Except as stated from page no. 107 in the Prospectus, all the Directors may be deemed to be interested to the extent of remuneration and fees payable to them for attending the meeting of the Board or committee thereof and reimbursement of traveling and other incidental expenses, if any, for such attendance as per the Articles of Association of our Company.

All the Directors/Promoters of our Company shall be deemed to be interested to the extent of shares held by them and/or their friend and relatives and which may be allotted to them out of the present issue, and are deemed to be interested to the extent of remuneration and perquisites being drawn by them from our Company.

Except as stated otherwise in this Prospectus, our Company has not entered into any contract, agreements or arrangement during the preceding two years from the date of the Prospectus in which the Directors are interested directly or indirectly and no payments have been made to them in respect of these contracts, agreements or arrangements which are proposed to be made to them.



**Payment of Benefit to Promoters of our Company**

Save as stated from page no. 107 in this Prospectus, no amount or benefit has been paid or given to our Company's Promoters since the incorporation of our Company nor is intended to be paid or given to any Promoter of our Company except their normal remuneration and/or reimbursement for services as Directors of our Company or otherwise in accordance with Law.

**Sales or Purchase between companies in the Promoter Group**

There are no Promoter Group Companies.



## 7. CURRENCY OF PRESENTATION

In this Prospectus, unless the context otherwise requires, all references to the word “Lakh” or “Lac”, means “One hundred thousand” and the word “million” means “Ten Lakhs “ and the word “Crore” means “ten million” and the word “billion” means “One thousand million and the word “trillion” means “One thousand billion”. In this Prospectus, any discrepancies in any table between total and the sum of the amounts listed are due to rounding off.

Throughout this Prospectus, all the figures have been expressed in Lakhs of Rupees, except when stated otherwise. All references to “Rupees” and “Rs.” in this Prospectus are to the legal currency of India.



## 8. RELATED PARTY TRANSACTIONS

### Transactions with Directors

**K. BALA KRISHNA RAO**

**K.T. VIJAY KUMAR**

**K.C.S PRASAD**

(Rs. In Lakhs)

PARTICULARS	For the Year ending on March 31				
	2008	2007	2006	2005	2004
Remuneration	31.67	31.80	19.60	20.60	17.94
Dividend	0	0		9.23	5.77
Total	31.67	31.80	19.60	29.83	23.71

Relatives Of Key Management Personnel and Transactions with them

**K. SUJATHA**

(Rs. In Lakhs)

PARTICULARS	For the Year ending on March 31				
	2008	2007	2006	2005	2004
Car Hire Charges	0.06	2.14	1.63	1.79	0.99

**K.SRINIVASA PRASAD**

(Rs. In Lakhs)

PARTICULARS	For the Years ending March 31				
	2008	2007	2006	2005	2004
Salary paid	1.50	3.75	3.77	-	-

**JETRO PETRO BIOTECH PVT. LTD**

(Rs. In Lakhs)

PARTICULARS	For the Years ending March 31				
	2008	2007	2006	2005	2004
Advance given	539.41	-	-	-	-



## 9. DIVIDEND POLICY

Dividends may be declared at the Annual General Meeting of the Shareholders based on a recommendation by the Board of Directors. The Board of Directors may recommend dividends, at its discretion, to be paid to the members. Generally the factors that may be considered by the Board, but not limited to, before making any recommendations for the dividend include future expansion plans and capital requirements, profits earned during the financial year, cost of raising funds from alternate sources, liquidity, applicable taxes including tax on dividend, as well as exemptions under tax laws available to various categories of investors from time to time and money market conditions. The dividends declared by our Company during the last five years are presented below:-

	For the year ended Mar 31st				
	2008	2007	2006	2005	2004
On equity shares					
No. of equity shares	10518200	10518200	6649000	720000	720000
Rate per centage	0	0	10%	16%	10%
Bonus issue	0	0	0	0	20%
Amount of dividend (Rs in lakhs)	0	0	31.1	11.52	7.2
Dividend tax (Rs in lakhs)	0	0	3.24	1.48	0.74
Total pay out (Rs in lakhs)	0	0	34.34	13	7.94

The amounts paid as dividend or bonus in the past is not indicative of our Company 's dividend policy in the future. Future dividends will depend upon the revenues, profits, cash flows, financial condition, capital requirements and other factors.

**SECTION V: FINANCIAL INFORMATION OF OUR COMPANY****1. FINANCIAL STATEMENTS OF OUR COMPANY****Auditors Report****Dt.12.07.2008****UNCONSOLIDATED SUMMARY STATEMENTS OF ASSETS AND LIABILITIES AS OF MARCH 31ST, 2008, 2007, 2006, 2005 AND 2004 AND PROFITS AND LOSSES AND CASH FLOWS FOR THE PERIOD ENDED MARCH 31ST, 2008, 2007, 2006, 2005 and 2004 AS RESTATED UNDER INDIAN GAAP, FOR M/ S.CHEMCEL BIOTECH LIMITED**

The Board of Directors

*M/s.Chemcel Biotech Limited*  
16-130/12,  
JRD Tata Industrial Estate  
Auto Nagar,  
Vijayawada -7

Dear Sirs,

We have Audited the Accounts of M/s Chemcel Bio-Tech Limited for the last five financial years ended 31.03.2004, 31.03.2005, 31.03.2006, 31.03.2007 and 31.03.2008 which the accounts of the Company have been made up and audited by us. Subject to our Report, Notes on Accounts & changes in accounting policies, of the said audited financial statements, at the date of signing this report, we are not aware of any material adjustment which would affect the result shown by these accounts in accordance with the requirement of Part II of Schedule II to the Companies Act, 1956.

In accordance with the requirements of Paragraph B (1) of Part II of Schedule II to the Companies Act 1956 (the Act), the Securities and Exchange Board of India (Disclosure and Investor Protection) Guidelines, 2000 (SEBI Guidelines) and our terms of reference with the Company dated 01.07.08 requesting us to make this report for the purpose of the Offering Memorandum as aforesaid, we report that:

- (a) The restated profits of the Company for the financial years ended 31st March, 2004, 31st March, 2005, 31st March, 2006, 31st March 2007 and 31.03.2008 are as set out in Annexure I to this report. These profits have been arrived at after charging all expenses including depreciation and after making such adjustment and regroupings as in our opinion are appropriate and more fully described in the Significant Accounting Policies and Notes appearing in Annexure III & IV respectively to this report.
- (b) The restated assets and liabilities of the Company as at 31st March, 2004, 31st March, 2005, 31st March, 2006, 31st March 2007 and 31.03.2008 are as set out in Annexure II to this report after making such adjustments and regroupings as in our opinion are appropriate and more fully described in the Significant Accounting Policies and Notes appearing in Annexure III & IV respectively to this report.
- (c) The restated cash flow statement of the Company as at 31st March, 2004, 31st March, 2005, 31st March, 2006, 31st March 2007 and 31.03.2008 are as shown in Annexure V to this report.
- (d) The rates of dividend paid by the Company in respect of the years/period ended 31st March, 2004, 31st March, 2005, 31st March, 2006, 31st March 2007 and 31.03.2008, are as shown in Annexure VI to this report.
- (e) We have examined the following financial information relating to the Company and as approved by the Board of Directors for the purpose of inclusion in the Offer document:
  - (i) Accounting Ratios as appearing in Annexure VII to this report.
  - (ii) Capitalisation Statement as at 31st March 2008 and post issue as appearing in Annexure VIII to this report.
  - (iii) Statement of tax shelters as appearing in Annexure IX to this report.
  - (iv) Details of other income as appearing in Annexure X to this report



- (v) Details of sundry debtors as appearing in Annexure XI to this report
- (vi) Details of loans and advances as appearing in Annexure XII to this report
- (vii) Details of unsecured loans as appearing in Annexure XIII to this report
- (viii) Details of secured loans as appearing in Annexure XIV to this report.
- (ix) Details of Transactions with related parties as appearing in Annexure XV to this report.

In our opinion the above financial information of the Company read with Significant Accounting Policies and notes on account attached in Annexure III & IV to this report, after making adjustments and re-grouping as considered appropriate has been prepared in accordance with Part II of Schedule II of the Act and the SEBI Guidelines.

This report is intended solely for your information and for inclusion in the Offer document in connection with the specific Public Offer of equity shares of the Company and is not to be used, referred to or distributed for any other purpose without our written consent.

Thanking you,

Yours faithfully

(T.NEHRU)  
CHARTERED ACCOUNTANT  
Membership No.15207





## ANNEXURE I

**Statement of Profit and Loss Account as Re-Stated**

Amount Rs lakhs

Particulars	For the year ended March 31				
	2008	2007	2006	2005	2004
Income					
Sales	2457.82	2333.69	2137.03	1290.51	1284.14
Other income	0.13	0.93	8.43	0.27	-4.09
Increase / (Decrease) in stocks	4.31	13.04	34.62	-66.97	57.91
<b>Total Income</b>	<b>2462.26</b>	<b>2347.66</b>	<b>2180.08</b>	<b>1223.81</b>	<b>1337.96</b>
<b>Expenditure</b>					
Manufacturing expenses	1862.49	1714.19	1528.30	603.60	617.87
Payment to employees	57.33	48.33	51.31	46.34	54.80
Other Expenditure	83.64	91.72	124.19	183.55	221.98
Selling expenses	174.74	273.98	330.75	305.99	401.31
Interest	107.18	60.03	41.51	23.64	10.45
Depreciation	10.78	12.47	12.84	14.20	14.42
Preliminary exps w/off	1.05	1.05	1.05	0.47	0.17
<b>Total Expenditure</b>	<b>2297.21</b>	<b>2201.77</b>	<b>2089.94</b>	<b>1177.79</b>	<b>1321.00</b>
Profit before tax	165.05	145.89	90.13	46.02	16.96
Current tax	42.4	52.47	14.46	27.64	8.55
Deferred tax	0.11	0.20			
<b>Profit after tax</b>	<b>122.76</b>	<b>93.62</b>	<b>75.68</b>	<b>18.39</b>	<b>8.41</b>
Income tax relating to earlier year					
<b>Net profit</b>	<b>122.76</b>	<b>93.62</b>	<b>75.68</b>	<b>18.39</b>	<b>8.41</b>

Note: During the FY 2006, 2007 and FY 2008, due to widespread rains in the area more area was brought-in under cropping leading to consumption of more pesticides in general. Further, our company has intensified marketing efforts through the dealer and distribution net work, introduction of new products coupled with cost saving measures leading to increase in sales and Net profit .



**ANNEXURE - II: SUMMARY OF STATEMENT OF ASSETS AND LIABILITIES, AS RESTATED**

(Rs. In Lakhs)

Particulars	As at March 31				
	2008	2007	2006	2005	2004
Assets :					
Fixed Assets (1)					
Gross Block	165.19	123.83	122.95	123.14	127.83
Less : Depreciation	36.10	25.31	12.84	14.20	14.42
Net Block	129.09	98.52	110.11	108.94	113.41
Add: Capital work in progress	0.00	13.00	580.22		
<b>Total Net Block</b>	<b>129.09</b>	<b>111.52</b>	<b>690.33</b>	<b>108.94</b>	<b>113.41</b>
Deferred Tax	0.32	0.20			
<b>Total</b>	<b>129.41</b>	<b>111.72</b>			
<b>Investment ( Non Trade) (2)</b>	<b>3.00</b>			1.00	1.00
<b>Current Assets, Loans and Advances (3)</b>					
Inventories	135.11	130.80	117.75	83.14	150.11
Sundry Debtors	1126.16	1062.69	660.10	491.86	371.82
Advances to Suppliers	702.76	325.90	445.08	58.05	18.84
Cash and Bank Balances	14.25	1.27	0.49	1.81	3.54
Loans, Advances & Other current assets	719.64	854.97	33.36	57.48	43.10
Total	2697.92	2375.63	1256.78	692.34	587.41
<b>Total Assets (1) + (2) + (3) = 4</b>	<b>2830.33</b>	<b>2487.35</b>	<b>1947.11</b>	<b>802.28</b>	<b>701.82</b>
Less : Liabilities and Provisions					
Secured Loans	665.64	607.96	406.63	285.08	94.91
Unsecured Loans	36.42	36.42	53.16	66.62	100.60
Sundry Creditors	334.78	330.14	161.41	72.88	166.60
Deposits from dealers	9.51	9.63	457.46		
Other Liabilities & Provisions	408.15	244.68	106.48	137.13	231.70
Provisions	46.56	53.05	53.81		
<b>Total (5)</b>	<b>1501.06</b>	<b>1281.88</b>	<b>1238.94</b>	<b>561.71</b>	<b>593.81</b>
<b>Net Worth</b>					
<b>Liabilities (-) - (5)</b>	<b>1329.27</b>	<b>1205.47</b>	<b>708.17</b>	<b>240.57</b>	<b>108.01</b>
Net Worth represented by :					
Share Capital	1051.82	1051.82	664.90	72.00	72.00
Share application money	0.00			161.60	30.00
Reserves & Surplus	278.50	155.75	46.42	11.17	6.01
Less : Miscellaneous Expenses (to the extent of not written off or adjusted)	-1.05	-2.10	-3.15	-4.20	
<b>Adjusted Net Worth</b>	<b>1329.27</b>	<b>1205.47</b>	<b>708.17</b>	<b>240.57</b>	<b>108.01</b>

**Annexure - III****SIGNIFICANT ACCOUNTING POLICIES:**

1. System of Accounting  
The accounts are prepared on accrual basis under the historical cost convention and to comply in all material aspects with applicable accounting principles in India, the Accounting Standards issued by the Institute of Chartered Accountants of India and the relevant provisions of the Companies Act, 1956.
2. Fixed Assets  
Fixed Assets are stated at cost of acquisition/construction, as the case may be, including borrowing costs upto the date of commissioning of related assets and all direct and indirect expenses related thereto.
3. Depreciation / Amortisation  
Depreciation on fixed assets is provided on Written down value method at the rate specified XIV to the Companies Act, 1956. Fixed Assets costing below Rs.5000/- are fully depreciated in the year of addition. Depreciation is provided on pro-rata basis with reference to the date of addition / deletion in respect of addition to / deletion from fixed assets.
4. Revenue recognition  
All expenses and income are recognised on accrual basis as per the requirements of the Companies Act.
5. Inventories
  - i. Raw materials are valued at cost.
  - ii. Finished goods are valued at lower of cost or net realisable value and for this purpose, cost is determined on direct cost basis.
  - iii. Stores (excepting paddy husk), spares and loose tools are valued at cost (FIFO basis).
6. Borrowing Costs  
Borrowing costs that are attributable to the acquisition/construction of qualifying assets are capitalised as part of cost of such assets. A qualifying asset is an asset that requires a substantial period of time to get ready for its intended use. All other borrowing costs are recognised as an expense in the year in which they are incurred.
7. Taxes on Income  
Provision for tax on income for the year (i.e. Current Tax) is made after considering the various deductions/relief admissible under the Income Tax Act, 1961.
8. CENVAT credit not availed in respect of capital goods.
9. SUBSIDY: The company is opted for sale tax deferment scheme and the amount of sales tax payable to sales tax department is payable from 14<sup>th</sup> year of deferment. The amounts are shown as Unsecured Loans and do not carry any interest.
10. SALES  
Sales includes Sales Tax
11. INVESTMENTS  
The company had taken 60% stake in Jetro Petro Biotech Pvt. Limited and invested Rs.3,00,000/- during the year 2007-08. It became Holding Company to Jetro Petro Biotech Pvt. Ltd. These Investments are shown at cost.

(Rs in Lakhs)

Particulars	As At				
	31.03.08	31.03.07	31.03.06	31.03.05	31.03.04
<b>a Estimated amount of Capital commitments (Net of Advances)</b>					
<b>b</b>					
<b>i. Excise Duty</b>	0.00	0.00	169.35	33.91	
<b>ii. Sales Tax Appeal pending with Hon'ble High Court, Hyderabad</b>	8.38	8.38	8.38	32.12	
<b>c Guarantee given to Banks</b>	62.00	62.00	62.00	0.00	

**Note:**

Central Excise Tribunal Bench at Bangalore has passed judgement in favour of the Company. So, Rs.178.26 lakhs is not shown as contingent liability

2. Additional information as required under paragraphs 3, 4C and 4D of Part II of Schedule VI to the Companies Act, 1956 are as under:-

**a. Details for each class of goods manufactured, sold and stocks**

(As certified by the Management)

Particulars	For the period/year ended on				
	31.03.08 Qty. (MT)	31.03.07 Qty. (MT)	31.03.06 Qty. (MT)	31.03.05 Qty. (MT)	31.03.04 Qty. (MT)
Capacity					
Licensed Capacity			-	-	-
- Liquids	1000 KL	1000 KL	1000 KL	1000 KL	1000 KL
- Granules	1000 MT	1000 MT	1000 MT	1000 MT	1000 MT
- Dusts	300 MT	300 MT	300 MT	300 MT	300 MT
Particulars	31.03.08	31.03.07	31.03.06	31.03.05	31.03.04
Liquids (in Lts)					
Opening stock	20283.2	12100	12,084	14,624	8,889
Production/Receipts	582677.3	269733.35	257170	2,07,045	2,09,357
Closing stock	26169.25	20283.2	12,100	12,084	14,624
Sales	576791.25	261550.15	2,57,154	2,09,585	2,03,622
Granules (in Kgs)	31.03.08	31.03.07	31.03.06	31.03.05	31.03.04
Opening stock	6594	0	8	13,248	0
Production/Receipts	29454	98202	4,53,536	2,95,001	57,936
Closing stock	48	6594		8	13,248
Sales	36000	91608	4,53,544	3,08,241	44,688
Dust (in Kgs)	31.03.08	31.03.07	31.03.06	31.03.05	31.03.04
Opening stock	1941.85	439	1,109	7,438	8,235
Production/Receipts	64363.8	32946.75	20,982	29,886	543
Closing stock	544.65	1941.85	439	1,108	7,438
Sales	65761	31443.9	21,652	36,216	1,340

The company is not dealing with foreign currency.

1. In the opinion of the Board and to the best of their knowledge and belief the value on realization of the current assets, loans and advances, if realized, in the ordinary course of business would not be less than the amount at which they are stated in the balance sheet. The provisions for all known liabilities are adequate and not in excess of amount considered reasonably necessary.
2. The company has pledged the stocks, Fixed Assets to the bank for obtaining working capital loans from Union Bank of India. The working directors have also stood as guarantors for the amounts borrowed from bank.



## 3. Directors Remuneration:

(Rs. in Lakhs)

PARTICULARS	31.03.08	31.03.07	31.03.06	31.03.05	31.03.04
Salary	30.63	30.42	19.60	8.40	8.40
Contribution to Provident Fund	0.72	0.72	0.72	0.31	0.31
Sitting Fee	0.32	0.66	0.50	-	-
Value of perquisites				11.90	9.23
<b>Total</b>	<b>31.67</b>	<b>31.80</b>	<b>20.81</b>	<b>20.61</b>	<b>17.94</b>

## 4. Auditors' Remuneration:

(Rs in lakhs)

PARTICULARS	31.03.08	31.03.07	31.03.06	31.03.05	31.03.04
Audit Fee	1.60	1.60	1.60	0.68	0.28
Consultancy on Taxation Matters	0		0.16	0.07	0.07
Other Professional Services	0				
Reimbursement of Expenses	0				
<b>Total</b>	<b>1.60</b>	<b>1.60</b>	<b>1.76</b>	<b>0.75</b>	<b>0.35</b>

5. Income tax assessment has been completed up to the assessment year 2004-05
6. As the company's business activity falls within a single segment viz. 'Pesticides', the disclosure requirements of Accounting Standard 17 "Segment Reporting" issued by the Institute of Chartered Accountants of India is not applicable.
7. The company has availed working capital facilities from Union Bank of India, Vijayawada main branch. The balance outstanding in this account as at Dec 31st, 2007 is about Rs.497.29 lakhs
8. Sundry Debtors / Creditors / Loans and Advances are subject to confirmation.
9. There are no amounts outstanding in respect of unpaid dividend.

## (a) Investments (Non Trade Long Term)

(Rs. in Lakhs)

PARTICULARS	31.03.08	31.03.07	31.03.06	31.03.05	31.03.04
Total cost of quoted Investments	-	-	-	-	-
Total cost of unquoted Investments	3.00	-	-	1.00	1.00
Aggregate Market value of quoted Invt.	-	-	-	-	-

10. The income of the company is not dependent upon a single (domestic/foreign) customer.
11. Figures of previous periods and have been regrouped/rearranged, wherever necessary.
12. There are no other material notes to the auditors' report which has bearing on the financial status of the company.
13. There are no adjustments which are brought out by the auditors and are not provided for.

We confirm that all notes to accounts, significant accounting policies and our qualifications have been incorporated.



## ANNEXURE V

(Rs in Lakhs)

**Statement of Cash Flow From The Restated Financial Statements  
For the Period Ended**

	31.03.08	31.03.07	31.03.06	31.03.05	31.03.04
<b>A Cash Flow From Operating Activities</b>					
Net(loss)/Profit Before Tax but after Exceptional /Extraordinary items	165.05	145.89	90.13	46.02	16.96
<b>Adjustments for :-</b>					
Depreciation	10.78	12.47	12.84	14.20	14.42
Miscellaneous Expenditure Written off	1.05	1.05	1.05	0.47	0.17
Provision for Tax	38.88				
Provision for FBT	3.52				
<b>Operating Profit before Working Capital changes</b>	<b>134.48</b>	159.41	104.02	60.69	31.55
(increase)/decrease in Sundry Debtors	63.46	(402.59)	(168.24)	(120.04)	(140.73)
(increase)/decrease in Advances to Suppliers	376.85	(34.67)	(387.03)	(39.22)	10.14
(increase)/decrease in Other Current Assets	(135.34)	(666.71)	24.12	(14.38)	(10.06)
(increase)/decrease in Inventories	4.31	(13.05)	(34.61)	66.97	(57.92)
increase/(decrease) in trade creditors & other Payables	161.60	306.18	55.60	(214.87)	203.68
increase/(decrease) in Share Application Money	0.00	0.00	(161.60)	131.60	27.65
<b>Cash generating from Operations</b>	<b>147.88</b>	(648.37)	(567.74)	(129.25)	64.32
Tax(paid)/received (Net of TDS)	-	-	-	(6.08)	(7.50)
<b>Net Cash from Operating Activities</b>	<b>147.88</b>	(648.37)	(567.74)	(135.33)	56.82
<b>B Cash Flow From Investing Activities</b>					
Purchase of Fixed Assets	41.37	0.68	0.19	(9.73)	(49.64)
Capital Work in Progress	(13.00)	567.22	(580.22)		
Proceeds from sale of Investments			1.00		
Purchase of Investments	3.00				
Prior Period expenses (income) net				(4.90)	
Others	0.00				
<b>Net Cash Used in Investing Activities</b>	<b>31.37</b>	<b>564.85</b>	<b>(579.03)</b>	<b>(14.63)</b>	<b>(49.64)</b>
<b>C Cash Flow From Financing Activities</b>					
Proceeds from fresh issue of share capital (Incl.Premium)	0.00	386.92	592.90	0.00	14.52
Net Proceeds from Long Term Borrowings	(0.12)	201.33	121.55	190.16	34.37
Net Proceeds from Short Term Borrowings	57.66	0.00	(30.20)	(33.98)	(45.28)
Deposits from Dealers		(464.57)	474.20		
Dividend Paid		(39.35)	(13.00)	(7.94)	(7.52)
<b>Net Cash used from Financing Activity</b>	<b>57.54</b>	<b>84.33</b>	<b>1145.45</b>	<b>148.24</b>	<b>(3.91)</b>
<b>Net increase/(decrease) in cash &amp; cash s equivalents(A+B+C)</b>	<b>12.96</b>	<b>0.81</b>	<b>(1.32)</b>	<b>(1.72)</b>	<b>3.27</b>
Cash & Cash Equivalents at the beginning of the year/period	1.29	0.48	1.80	3.52	0.26
Cash & Cash Equivalents at the End of the year/period	14.25	1.29	0.48	1.80	3.52

**Annexure VI****Statement of Dividend paid for the last 5 years**

<b>For the year ended</b>	<b>31.03.08</b>	<b>31.03.07</b>	<b>31-03-06</b>	<b>31-03-05</b>	<b>31-03-04</b>
On equity shares					
No. of equity shares	105.18	105.18	66.49	7.2	7.2
Rate per centage	0	0	10%	16%	10%
Bonus issue	0	0	0	0	20%
Amount of dividend (Rs in Lakhs)	0	0	31.1	11.52	7.2
Dividend tax (Rs in Lakhs)	0	0	3.24	1.48	0.74
Total pay out (Rs in Lakhs)	0	0	34.34	13	7.94

**Annxure VII****Statement of Accounting Ratios**

(Rs in Lakhs)

<b>Particulars</b>	<b>For the year ending on</b>				
	<b>31.03.08</b>	<b>31.03.07</b>	<b>31.03.06</b>	<b>31.03.05</b>	<b>31.03.04</b>
Profit before tax	165.05	145.89	90.14	46.02	16.96
Add/(Less) : Exceptional Item				0.00	0.00
Profit Before Tax	165.05	145.89	90.14	46.02	16.96
Less: Provision for Current Tax	42.29	52.47	14.46	27.64	8.55
Profit after Current Tax	122.76	93.42	75.68	18.38	8.41
No. Of Equity Shares	105.18	105.18	66.49	7.20	7.20
EPS Basic / Diluted (Rs. Per Share)					
-After Current Tax ( Profit After Tax/ No.of Equity Shares)	1.17	0.89	1.14	2.55	1.17
Cash EPS(Profit After Tax+ Dereciation) /No.of Shares)	1.27	1.01	1.33	4.53	3.17
<b>Net Worth / NAV / Return on Net Worth</b>					
Profit After Tax	122.76	93.42	75.68	18.38	8.41
-Net Worth= Equity + Reserves - Misc. expenses to the extent of not written off	1329.27	1,205.47	708.17	78.97	78.01
Return on Net Worth % (Profit after tax/Net Worth)	9.24	7.75	10.69	23.27	10.78
Net Asset Value per Share (NAV) (Net Worth/ No. of Shares)	12.64	11.46	10.65	10.97	10.83

**ANNEXURE VIII****Capitalization Statement**

(Rs in lakhs)

	<b>Particulars</b>	<b>Pre Issue</b>	<b>Post Issue</b>
1	Secured Loans	665.64	162.84
2	Un Secured Loans	45.93	45.93
3	Total Debt	711.57	208.77
4	Less : Short Term Debt	665.64	162.84
5	Total Long Term Debt	45.93	45.93
	<b>Share Holders Funds</b>		
6	Share Capital	1051.82	2591.82
7	Reserves & Surplus	278.50	1202.50
8	Total Share Holders Funds	1330.32	3794.32
	<b>Long Term Debt/ Equity Ratio (5 / 8)</b>	<b>0.03</b>	<b>0.01</b>

**ANNEXURE IX:****TAX SHELTER STATEMENT**

<b>PARTICULARS</b>	<b>31.03.08</b>	<b>31.03.07</b>	<b>31.03.06</b>	<b>31.03.05</b>	<b>31.03.04</b>
Tax Rate ( incl. Surcharge & Education Cess)	33.66%	33.66%	37%	37%	36%
Profit as per Profit and Loss Account	165.05	145.89	90.13	46.02	16.96
Tax at Notional Rate	38.88	49.11	33.35	17.03	6.11
<b>Adjustments</b>					
Difference between Tax depreciation & Book Depreciation	0.34	(0.59)	(0.16)	1.49	(0.66)
Other Adjustments	49.52	0.00	47.09	(32.71)	6.09
<b>Net Adjustments</b>	<b>49.86</b>	<b>0.59</b>	<b>(46.94)</b>	<b>(31.22)</b>	<b>5.43</b>
Tax Savings thereon	16.78	0.20	(17.37)	(11.55)	1.95

**ANNEXURE X:****DETAILS OF OTHER INCOME**

(Rs in Lakhs)

<b>Particulars</b>	<b>For the Period ending on</b>				
	<b>31.03.08</b>	<b>31.03.07</b>	<b>31.03.06</b>	<b>31.03.05</b>	<b>31.03.04</b>
Miscellaneous Income					
Dividend on Chits			3.65	0.27	(4.09)
Sales Tax set off Received					
Interest on Sales Tax Deposites					
Field Promotional Fee					
Credit notes from suppliers					
Profit on Sale of Investment			4.78		
Other Interest	0.13	0.93			
<b>Total</b>	<b>0.13</b>	<b>0.93</b>	<b>8.43</b>	<b>0.27</b>	<b>(4.09)</b>



**ANNEXURE - XI****Sundry Debtors**

(Rs in Lakhs)

Particulars	For the Period ending on				
	31.03.08	31.03.07	31.03.06	31.03.05	31.03.04
Over Six Months	181.45	114.81	29.96	49.19	35.10
Other Debts	944.71	947.88	630.14	442.67	336.72
Total	1,126.16	1,062.69	660.10	491.86	371.82
Less : Provision for Doubtful Debts					
Total	1,126.16	1,062.69	660.10	491.86	371.82

Note: None of the Debtors is related to the Directors / Promoters of the Company.

**ANNEXURE - XII****Loans and Advances (Unsecured considered Good)**

(Rs in Lakhs)

Particulars	For the period / year ended				
	31.03.08	31.03.07	31.03.06	31.03.05	31.03.04
Advances recoverable in cash or in kind or for value to be received	702.76	325.9	445.08	113.95	60.36
Other Advances	718.11	853.44	31.73		
Deposits	1.53	1.53	1.60	1.58	1.58
Total	1422.4	1,180.87	478.41	115.53	61.94

**ANNEXURE XIII :****STATEMENT OF UNSECURED LOANS**

(Rs in Lakhs)

Particulars	For the Year ending on				
	31.03.08	31.03.07	31.03.06	31.03.05	31.03.04
From Promotor/ Directors			16.74		
From Associate/group Companies					
Others					
-Loans				30.20	64.19
-Sales Tax Deferment	36.42	36.42	36.42	36.42	36.42
Others	9.51	9.63			
Total	45.93	46.05	53.16	66.62	100.61



## ANNEXURE - XIV :

## STATEMENT OF EXISTING SECURED LOANS

(Rs in Lakhs)

Particulars of Loan	Bank	Nature of Loan	Sanctioned Amount ding	Amount outstan-	Rate of Intt	Repayment terms	Securities Offered
Working Capital Facility	Union Bank of India Vijayawada Main Branch	Working Capital Loan	530.00	497.28	12.00	On Demand	Hypothication of stocks, raw marterials, finished goods of pesticides, fungicides and bio fertilizers and book debts not less than 90 days and personal guarantee of Directors
Short Term Loan	Union Bank of India Vijayawada Main Branch		120.00	131.56	12.00	On Demand	Same as above
Term Loan	Kotak Mahendra Bank Ltd, Vijayawada	Term Loan	38.80	36.79	18.46	Monthly installment	Hypothication of Kondapalli Site
Car Loan	Lakshmi General Finance Ltd	Term Loan	3.99	0.55		Monthly installment	Hypothication of Car

## PARTICULARS OF SECURED LOANS AVAILED IN THE PREVIOUS 5 YEARS

(Rs lakhs)

Particulars	31.03.08	31.03.07	31.03.06	31.03.05	31.03.04
a. Term Loans					
Andhra Bank	-	-	-	-	-
Union Bank of India	131.56	121.09			
Kotak Mahendra Bank Ltd	36.79				
b. Working Capital Loans					
Andhra Bank	-	-	-	-	-
Corporation Bank	-	-	-	-	94.92
Union Bank of India	497.29	486.12	406.63	285.08	-
c. Lakshmi General Finance Ltd.	0.55	1.58			
<b>Total</b>	<b>666.19</b>	<b>608.79</b>	<b>406.63</b>	<b>285.08</b>	<b>94.92</b>

There are no re-schedulement, pre-payment, penalties, default of the above loans.

Other collateral Securities offered:

- Three stored industrial building (2 blocks) constructed in an extent of 1849.02 sq. yards at R.S.No.183/1, Asst.No.3302, D.No.16-130/12, III cross road, JRD Tata industrial estate, Kanuru, Penamaluru Mandal, Krishna Dt., in the name of M/s Chemcel Bio-Tech Ltd. Valued Rs.118.00 lakhs.
- 493.28 Sq.yards of residential vacant site situated at R.S.No.460, plot No.28 (Nearest D.No.54-20/4-11), Gurunanak colony, Vijayawada in the name of Mr. K .T. Vijaya Kumar valued Rs.49.39 lakhs.



3. Plot No.101, (Plinth Area 44.37 Sq .Yards) at R.S.No.10/8, Sindhur Appts, Gayatrinagar, Vijayawada. In the name of Mr.K.Balakrishna Rao, valued Rs.14.59 lakhs.
4. 393.30 Sq.Yards of residential sites along with RCC framed structure at R.S.No. 43/1(Part), Asst.No.151235, nearest D.No.42-4-121/2; Temple street, Mutyalampadu, Ramakrishnapuram, Vijayawada. In the name of Sri.M.V.R.Sastry, valued Rs.22.39 lakhs.
5. 888.88 Sq.Yards of residential vacant site situated at S.No.160, Plot No.70,71,80 and 81 at Kapra, near Hyderabad, Kesara Mandal, R.R District, owned by Sri.K.T.Vijaya Kumar, valued Rs.19.56 lakhs.

**Personal Guarantee**

Personal guarantee of all the Directors in their individual capacity and Mr. M. V. R. Sastry.

**ANNEXURE XV : STATEMENT OF TRANSACTIONS WITH RELATED PARTIES IN PRECEDING 3 YEARS**

Key Management Personnel ( Directors Transactions with them)

**K. BALA KRISHNA RAO**

**K.T. VIJAY KUMAR**

**K.C.S PRASAD**

(Rs. In Lakhs)

PARTICULARS	For the Year ending on				
	31.03.08	31.03.07	31.03.06	31.03.05	31.03.04
Remuneration	31.67	31.80	19.60	20.60	17.94
Dividend	0	0		9.23	5.77
<b>Total</b>	<b>31.67</b>	<b>31.80</b>	<b>19.60</b>	<b>29.83</b>	<b>23.71</b>

Relatives Of Key Management Personnel and Transactions with them

**K. SUJATHA**

(Rs. In Lakhs)

PARTICULARS	For the Year ending on				
	31.03.08	31.03.07	31.03.06	31.03.05	31.03.04
Car Hire Charges	0.06	2.14	1.63	1.79	0.99

**K.SRINIVASA PRASAD**

(Rs. In Lakhs)

PARTICULARS	For the Year ending on				
	31.03.08	31.03.07	31.03.06	31.03.05	31.03.04
Salary paid	1.50	3.75	3.77	-	-

**JETRO PETRO BIOTECH PVT. LTD**

(Rs. In Lakhs)

PARTICULARS	For the Year ending on				
	31.03.08	31.03.07	31.03.06	31.03.05	31.03.04
Advance given	539.41	-	-	-	-

**2. Financial Information of group companies**

There are no group companies of the Company.

**Details about Companies/Firms from which promoters have disassociated during the last three years**

Our promoters have not disassociated from any Companies/ Firms in last three years.

**Companies for which an application has been made for striking off name**

There are no companies associated with our Company, Our Promoters and its directors, for which an application has been made with the Registrar of Companies for striking off the names of those companies.

**Changes in Accounting Policies During Preceding Three Years**

There have been no changes in accounting policies of our Company, during preceding three years.

**NOTES ON ACCOUNTS****Basic of Accounting**

The financial statements are prepared under the historical cost conventions on the basis of going concern and as per applicable Indian accounting standards and are based on the accrual basis of accounting.

**Revenue Recognition**

All expenses and income are accounted for on accrual basis as per the requirements of the Companies Act except staff retirement benefits.

**Miscellaneous and Preliminary Expenses**

Expenses incurred before the formation of the Company are shown as preliminary expenses.

**Loans and Advances**

- It includes the amount paid to the farmers for advance to supply the Bio Diesel seed.
- Value of Imports and indigenous materials consumed : NIL
- Value of imports on GIF basis NIL
- Expenditure in foreign currency NIL
- Earnings in foreign exchange on cash basis NIL
- Figures of previous year have been re-grouped wherever necessary NIL

**T. NEHRU**

Chartered Accountant  
Membership No.15207

Place: VIJAYAWADA

Date : 12.07.2008

**2.FINANCIAL INFORMATION OF OUR SUBSIDIARY COMPANY****Auditors Report**

Dt. 12.07.2008

UNCONSOLIDATED SUMMARY STATEMENTS OF ASSETS AND LIABILITIES AS OF 31st MARCH 2008, AND PROFITS AND LOSSES AND CASH FLOWS FOR THE YEAR ENDED 31st MARCH 2008 AS RESTATED UNDER INDIAN GAAP, FOR M/S.JETRO PETRO BIOTECH PRIVATE LIMITED .

*The Board of Directors*

M/s.Jetro Petro Biotech (P) Ltd  
29-36-37, GROUND FLOOR, AMMANA ESTATE  
MUSEUM ROAD, GOVERNERPET  
Vijayawada -520 002

Dear Sirs,

We have examined the financial accounts of M/s JETRO PETRO BIOTECH (P) LIMITED for year ended 31.03.2008 which the accounts of the Company have been made up and audited by us. Subject to our Report, Notes on Accounts & changes in accounting policies, of the said audited financial statements, at the date of signing this report.

- (i) Paragraph B (1) of Part II of Schedule II to the Companies Act 1956 (the Act),
- (ii) The Securities and Exchange Board of India (Disclosure and Investor Protection) Guidelines, 2000 (SEBI Guidelines) issued by Securities and Exchange Board of India (SEBI) in pursuance to Section 11 of the Securities and Exchange Board of India Act, 1992 and related amendments
- (iii) The Guidance Note on the Reports in Company prospectus issued by the Institute of Chartered Accountants of India (ICAI) and
- (iv) The terms of our letter of engagement with the Company requesting us to carry out work in connection with the document being issued by the company in connection with its holding IPO of equity shares.
  - (b) The restated profits of the Company for the financial year ended 31.03.2008 are as set out in Annexure I to this report. These profits have been arrived at after charging all expenses including depreciation and after making such adjustment and regroupings as in our opinion are appropriate and more fully described in the Significant Accounting Policies and Notes appearing in Annexure III & IV respectively to this report.
  - (c) The restated assets and liabilities of the Company for year ended 31.03.2008 are as set out in Annexure II to this report after making such adjustments and regroupings as in our opinion are appropriate and more fully described in the Significant Accounting Policies and Notes appearing in Annexure III & IV respectively to this report.
  - (d) The restated cash flow statement of the Company for year ended 31.03.2008 are as shown in Annexure V to this report.
  - (e) The rates of dividend paid by the Company in respect of the year ended 31.03.2008, are as shown in Annexure VI to this report.
  - (f) We have examined the following financial information relating to the Company and as approved by the Board of Directors for the purpose of inclusion in the Offer document:
    - (ii) Accounting Ratios as appearing in Annexure VII to this report.
    - (iii) Capitalisation Statement as at 31st March 2008 and post issue as appearing in Annexure VIII to this report
    - (iv) Statement of tax shelters as appearing in Annexure IX to this report.
    - (v) Details of other income as appearing in Annexure X to this report



- (vi) Details of sundry debtors as appearing in Annexure XI to this report
- (vii) Details of loans and advances as appearing in Annexure XII to this report
- (viii) Details of unsecured loans as appearing in Annexure XIII to this report
- (ix) Details of secured loans as appearing in Annexure XIV to this report.
- (x) Details of Transactions with related parties as appearing in Annexure XV to this report.

In our opinion the above financial information of the Company read with Significant Accounting Policies and notes on account attached in Annexure III & IV to this report, after making adjustments and re-grouping as considered appropriate has been prepared in accordance with Part II of Schedule II of the Act and the SEBI Guidelines.

This report should not be in any way construed as a re-issuance or re-dating of any or the previous audit by us or by any other firm of chartered accountants, nor should it be construed as a new opinion on any statements referred to therein.

This report is intended solely for your information and for inclusion in the Offer document in connection with the specific Public Offer of equity shares of the Company and is not to be used, referred to or distributed for any other purpose without our written consent.

Thanking you,  
Yours faithfully

(T.NEHRU)  
CHARTERED ACCOUNTANT  
Member ship No.15207

## ANNEXURE I

### Statement of Profit and Loss Account as Re-Stated

Particulars	For the period ended 31.03.08 (in Lakhs)
<b>Income</b>	
Sales	0
Total Income	0
<b>Expenditure</b>	
Payment to employees	1.38
Other Expenditure	0.45
Preliminary exps w/off	0
<b>Total Expenditure</b>	0.14
Profit before tax	(1.98)
Net profit/loss transferred to Balance sheet	(1.98)



## ANNEXURE II

## Balance Sheet

(Rs. In Lakhs)

Particulars	For the Period ending on 31.03.08
<b>Fixed Assets (1)</b>	
Gross Block	0.30
Less : Depreciation	0
Net Block	0.30
<b>Current Assets, Loans and Advances (2)</b>	
Advances to Suppliers	
Cash and Bank Balances	0.03
Loans, Advances & Other current assets	541.88
	541.91
<b>Total Assets (1) + (2) = 3</b>	<b>542.21</b>
<b>Less : Liabilities and Provisions</b>	
Other Liabilities & Provisions	539.61
<b>Total (4)</b>	<b>539.61</b>
<b>Net Worth</b>	
<b>Liabilities (3) - (4)</b>	2.60
Net Worth represented by :	
Share Capital	5.00
Profit & Loss account	(1.97)
Less : Miscellaneous Expenses ( to the extent of not written off or adjusted )	(0.43)
<b>Adjusted Net Worth</b>	<b>2.60</b>

## Annexure - III

## SIGNIFICANT ACCOUNTING POLICIES:

## 1. System of Accounting

The accounts are prepared on accrual basis under the historical cost convention and to comply in all material aspects with applicable accounting principles in India, the Accounting Standards issued by the Institute of Chartered Accountants of India and the relevant provisions of the Companies Act, 1956.

## Miscellaneous Expenses

Effective 01.04.2007, such expenditure is written off as incurred in accordance with 'AS-26 Intangible Assets', within 4 years.

## 3. Fixed Assets

Fixed assets are recorded at cost only.

## 4. Depreciation

Depreciation not provided on Fixed assets for this year.



## 5 Retirement Benefits

As the company is less than one year, no provision is made.

## 6. Subsidiary

The company became a subsidiary to Chemcel Biotech limited, after Chemcel Biotech Limited invested 60% in the share capital.

**Annexure - IV****Notes on Accounts**

Contingent Liability not provided for :

Particulars	Rs.in lakhs 31.03.08
Estimated amount of Capital	
a Commitments (Net of Advances)	
b Excise Duty & Sales Tax	0.00
c Guarantee given to Banks	0

2. Additional information as required under paragraphs 3, 4C and 4D of Part II of Schedule VI to the Companies Act, 1956 are as under:-

a. Consolidated Details for each class of goods manufactured, sold and stocks (As certified by the Management)

Particulars	For the period/ year ended on 31.03.08 Qty. (MT)
Capacity	N.A.
Licensed Capacity	N.A.
Installed Capacity	N.A.
- Liquids	N.A.
- Granules	N.A.
- Dusts	N.A.
Particulars	N.A.
Liquids (in Lts)	N.A.
Opening stock	N.A.
Production/Receipts	N.A.
Closing stock	N.A.
Sales	N.A.
Granules (in Kgs)	N.A.
Opening stock	N.A.
Production/Receipts	N.A.
Closing stock	N.A.
Sales	N.A.
Dust (in Kgs)	N.A.
Opening stock	N.A.
Production/Receipts	N.A.
Closing stock	N.A.
Sales	N.A.





## 3. Directors Remuneration:

(Rs. in Lakhs)

PARTICULARS	31.03.08
Salary	0
Contribution to Provident Fund	0
Sitting Fee	
Value of perquisites	
<b>Total</b>	<b>0</b>

## 4. Auditors' Remuneration:

Rs. in lakhs

PARTICULARS	31.03.08
Audit Fee	0.10
Consultancy on Taxation Matters	0
Other Professional Services	0
Reimbursement of Expenses	0
Total	0.10

## 5. Sundry Debtors / Creditors / Loans and Advances are subject to confirmation.

## (a) Investments

(Rs. in Lakhs)

PARTICULARS	31.03.08
Total cost of quoted Investments	-
Total cost of unquoted Investments	-
Aggregate Market value of quoted Invt.	-

**CASH FLOW STATEMENT FOR THE YEAR ENDING 31.03.2008**

<b>A</b>	<b>Cash Flow From Operating Activities</b>	<b>31.03.08</b>
	Net(loss)/Profit Before Tax but after	
	Exceptional /Extraordinary items	(1.98)
	Adjustments for :-	
	Miscellaneous Expenditure Written off	0.14
	<b>Operating Profit before Working Capital changes</b>	<b>(1.84)</b>
	Adjustments for change in working capital :	
	(increase)/decrease in Other Current Assets	541.88
	increase/(decrease) in trade creditors & other Payables	539.62
	<b>Cash generating from Operations</b>	<b>(2.26)</b>
	<b>Net Cash from Operating Activities</b>	
<b>B</b>	<b>Cash Flow From Investing Activities</b>	
	Purchase of Fixed Assets	0.30
	Net Cash Used in Investing Activities	
	Increase in preliminary expenditure	0.57



C

**Cash Flow From Financing Activities**

Proceeds from fresh issue of share capital	5.00
<b>Net Cash used from Financing Activity</b>	
Net increase/(decrease) in cash & cash equivalents(A+B+C)	(4.97)
Cash & Cash Equivalents at the beginning of the year/period	—
Cash & Cash Equivalents at the End of the year/period	<b>0.03</b>

**ANNEXURE V I- Dividend paid for the last 5 years**

For the year ended	31.03.08
On equity shares	
No. of equity shares	0.50
Rate per centage	0
Amount of dividend (Rs in Lakhs)	0
Dividend tax (Rs in Lakhs)	0
Total pay out (Rs in Lakhs)	0

**ANNEXURE VII - Statement of Accounting Ratios**

(Rs in Lakhs)

Particulars	For the year ending on 31.03.08
Profit Before Tax	(1.98)
Less: Provision for Current Tax	0
Profit after Current Tax	(1.98)
No. Of Equity Shares	0.50
<b>EPS Basic / Diluted (Rs. Per Share )</b>	
-After Current Tax ( Profit After Tax/ No.of Equity Shares)	(3.96)
Cash EPS(Profit After Tax+ Depreciation)/No.of Shares)	(3.96)
<b>Net Worth / NAV / Return on Net Worth</b>	
Profit After Tax	(1.98)
-Net Worth= Equity + Reserves - Misc. expenses to the extent of not written off	2.60
Return on Net Worth %	
(Profit after tax/Net Worth)	(0.76)
Net Asset Value per Share (NAV)	
(Net Worth/ No. of Shares)	5.20



## ANNEXURE VIII

## Capitalization Statement

(Rs in lakhs)

Particulars	Pre Issue	Post Issue
1 Secured Loans	0	0
2 Un Secured Loans	0	0
3 Total Debt	0	0
4 Less : Short Term Debt	0	0
5 Total Long Term Debt	0	0
Share Holders Funds		
6 Share Capital	5.00	5.00
7 Reserves & Surplus	(1.98)	(1.98)
8 Total Share Holders Funds	3.02	3.02

Long Term Debt/ Equity Ratio (5 / 8)

## Tax Shelter Statement

(Rs in Lakhs)

PARTICULARS	31.03.08
Tax Rate ( incl. Surcharge & Education Cess)	0
Profit as per Profit and Loss Account	0
Tax at Notional Rate	0
Adjustments	0
Difference between Tax depreciation & Book Depreciation	0
Other Adjustments	0
Net Adjustments	0
Tax Savings thereon	0

## ANNEXURE X

## Details of Other Income

(Rs in Lakhs)

Particulars	For the Period ending on 31.03.08
Miscellaneous Income	-
Dividend on Chits	-
Sales Tax set off Received	-
Interest on Sales Tax Deposits	-
Field Promotional Fee	-
Credit notes from suppliers	-
Profit on Sale of Investment	-
Other Interest	-
Total	-

## ANNEXURE - XI : Sundry Debtors

Rs. in lakhs

Particulars	For the Period ending on 31.03.08
Over Six Months	0
Other Debts	0
<b>Total</b>	<b>0</b>
Less : Provision for Doubtful Debts	
<b>Total</b>	<b>0</b>

Note: None of the Debtors is related to the Directors / Promotors of the Company.

**ANNEXURE - XII: Loans and Advances ( Unsecured considered Good)****(Rs. lakhs)**

Particulars	For the period / year ended 31.03.08
Advances recoverable in cash or in kind or for value to be received	539.410.00
Other Advances	0
Deposits	0
<b>Total</b>	<b>539.410.00</b>

**ANNEXURE XIII : Statement of Unsecured Loans****(Rs in Lakhs)**

	Particulars	For the Year ending on 31.03.08
A	From Promotor/ Directors	0
B	From Associate/group Companies	0
C	Others	0
	<b>Total</b>	<b>0</b>

**ANNEXURE - XIV : Statement of Existing Secured Loans:**

Particulars of Loan	Bank	Nature of Loan	Sancti- oned Amount	Amount out- standing as at (31.12.07)	Rate of Interest %	Repayment of terms	Securities Offered
Nil	Nil	Nil	Nil				

**Particulars of paid secured loans availed in the previous years****(Rs lakhs)**

Particulars	For the period/year ended on 31.03.08
a. Term Loans	
Union Bank of India	0
b. Working Capital Loans	
Union Bank of India	0
<b>Total</b>	<b>0</b>

**ANNEXURE XV : Statement of Transactions with related parties in preceding 3 years****Key Management Personnel ( Directors Transactions with them)****NIL****(Rs. In Lakhs)**

PARTICULARS	For the Year ending on 31.03.08
Remuneration	0
Dividend	0
<b>Total</b>	<b>0</b>

Relatives Of Key Management Personnel and Transactions with them .. NIL

**2. Financial Information of group companies**

There are no group companies of the Company.

**Auditors Report**

Dt. 12.07.2008

CONSOLIDATED SUMMARY STATEMENTS OF ASSETS AND LIABILITIES AS OF 31ST March 2008 AND PROFITS AND LOSSES AND CASH FLOWS FOR THE PERIOD ENDED 31ST MARCH 2008 AS RESTATED UNDER INDIAN GAAP, FOR M/S.CHEMCEL BIOTECH LIMITED

The Board of Directors

*M/s.Chemcel Biotech Limited*  
16-130/12,  
JRD Tata Industrial Estate  
Auto Nagar,  
Vijayawada -7

Dear Sirs,

We have examined the consolidated financial accounts of M/s Chemcel Bio-Tech Limited and its subsidiary for the year ended 31.03.2008 which the accounts of the Company have been made up and audited by us. Subject to our Report, Notes on Accounts & changes in accounting policies, of the said audited financial statements, at the date of signing this report, for the purpose of disclosure in the offer document, being issued by the Company in connection with the Public Issue (IPO) for the issue of 1,54,00,000 equity shares having the facing value of Rs.10/- each at an issue price to be arrived by the book building process. This consolidated financial information has been prepared in and with the requirements of

- (i) Paragraph B (1) of Part II of Schedule II to the Companies Act 1956 (the Act),
- (ii) The Securities and Exchange Board of India (Disclosure and Investor Protection) Guidelines, 2000 (SEBI Guidelines) issued by Securities and Exchange Board of India (SEBI) in pursuance to Section 11 of the Securities and Exchange Board of India Act, 1992 and related amendments
- (iii) The Guidance Note on the Reports in Company prospectus issued by the Institute of Chartered Accountants of India (ICAI) and
- (iv) The terms of our letter of engagement with the Company requesting us to carry out work in connection with the document being issued by the company in connection with its IPO of equity shares.
- (c) The consolidated restated profits of the Company for the financial period ended 31.03.2008 are as set out in Annexure I to this report. These profits have been arrived at after charging all expenses including depreciation and after making such adjustment and regroupings as in our opinion are appropriate and more fully described in the Significant Accounting Policies and Notes appearing in Annexure III & IV respectively to this report.
- (d) The consolidated restated assets and liabilities of the Company as at period ended 31.03.2008 are as set out in Annexure II to this report after making such adjustments and regroupings as in our opinion are appropriate and more fully described in the Significant Accounting Policies and Notes appearing in Annexure III & IV respectively to this report.
- (e) The consolidated restated cash flow statement of the Company for the period ended 31.03.2008 are as shown in Annexure V to this report.
- (f) The rates of dividend paid by the Company in respect of the period ended 31.03.2008, are as shown in Annexure VI to this report.
- (g) We have examined the following consolidated financial information relating to the Company and as approved by the Board of Directors for the purpose of inclusion in the Offer document:



- (iii) Consolidated Accounting Ratios as appearing in Annexure VII to this report.
- (iv) Consolidated Capitalisation Statement as at 31st March 2008 and post issue as appearing in Annexure VIII to this report
- (v) Consolidated Statement of tax shelters as appearing in Annexure IX to this report.
- (vi) Consolidated Details of other income as appearing in Annexure X to this report
- (vii) Consolidated Details of sundry debtors as appearing in Annexure XI to this report
- (viii) Consolidated Details of loans and advances as appearing in Annexure XII to this report
- (ix) Consolidated Details of unsecured loans as appearing in Annexure XIII to this report
- (x) Consolidated Details of secured loans as appearing in Annexure XIV to this report.
- (xi) Consolidated Details of Transactions with related parties as appearing in Annexure XV to this report.

In our opinion the above consolidated financial information of the Company read with Significant Accounting Policies and notes on account attached in Annexure III & IV to this report, after making adjustments and re-grouping as considered appropriate has been prepared in accordance with Part II of Schedule II of the Act and the SEBI Guidelines.

This report should not be in any way construed as a re-issuance or re-dating of any or the previous audit by us or by any other firm of chartered accountants, nor should it be construed as a new opinion on any statements referred to therein.

This consolidated report is intended solely for your information and for inclusion in the Offer document in connection with the specific Public Offer of equity shares of the Company and is not to be used, referred to or distributed for any other purpose without our written consent.

Thanking you,

Yours faithfully,

(T.NEHRU)  
CHARTERED ACCOUNTANT  
Membership No.15207



## CHEMCEL BIOTECH LIMITED - ANNEXURE I

## Consolidated Statement of Profit and Loss Account as Re-Stated

Particulars	For the period ended 31.03.08 (in lakhs)
Sales	2457.82
Other income	0.13
Increase / (Decrease) in stocks	4.31
<b>Total Income</b>	<b>2462.26</b>
<b>Expenditure</b>	
Manufacturing expenses	1862.49
Payment to employees	58.71
Other Expenditure	84.09
Selling expenses	174.74
Interest	107.18
Depreciation	10.79
Preliminary exps w/off	1.19
<b>Total Expenditure</b>	<b>2299.19</b>
Profit before tax	163.07
Current tax	38.89
F.B.T.	3.51
Deferred tax	0.11
Minority Interest	0.79
<b>Profit after tax</b>	<b>121.57</b>
Income tax relating to earlier year	
<b>Net profit</b>	<b>121.57</b>

Note: The above statements should be read with the notes on the adjustments to consolidate the restated financial statements significant accounting policies and notes forming part of accounts as appearing in Annexure III.



## CHEMCEL BIOTECH LIMITED - ANNEXURE II

## Consolidated Balance Sheet

(Rs. In akhs)

Particulars	For the Period ending on 31.03.08
<b>Fixed Assets (1)</b>	
Gross Block	165.19
Less : Depreciation	36.10
Net Block	129.39
<b>Deferred Tax</b>	<b>0.31</b>
<b>Total</b>	<b>129.70</b>
<b>Investment ( Non Trade) (2)</b>	
<b>Current Assets, Loans and Advances(3)</b>	
Inventories	135.11
Sundry Debtors	1126.16
Advances to Suppliers	702.76
Cash and Bank Balances	14.29
Loans, Advances & Other current assets	722.11
Total	2700.43
<b>Total Assets (1) + (2) + (3) = 4</b>	<b>2830.13</b>
<b>Less : Liabilities and Provisions</b>	
Secured Loans	665.64
Unsecured Loans	36.42
Sundry Creditors	334.78
Deposits from dealers	9.51
Other Liabilities & Provisions	408.35
Provisions	46.56
<b>Total (5)</b>	<b>1501.26</b>
<b>Net Worth</b>	
<b>Liabilities (4) - (5)</b>	<b>1328.87</b>
Net Worth represented by :	
Share Capital	1051.82
Share Application Money	0.00
Reserves & Surplus	277.32
Minority Interest	1.21
Less : Miscellaneous Expenses (to the extent of not written off or adjusted)	-1.48
<b>Adjusted Net Worth</b>	<b>1328.87</b>

Notes: The consolidated restated summary statement of Assets & Liabilities of the Company are not furnished for the financial year ended 31st March 2004, 2005, 2006 and 2007 and the Company had invested in the subsidiary company for the first time during the financial year 2007-08.





## NOTES ON ACCOUNTS

### ***Basis of Accounting***

The consolidated financial statements of Chemcel Biotech Limited and its subsidiary Jetro Petro Biotech Pvt. Ltd. are prepared under the historical cost convention in accordance with generally accepted principles in India and the accounting Standard 21 on 'Consolidated Financial statements', to the extent possible in the same format as that adopted by the Company for its separate financial statements.

### ***Principles of Consolidation***

*The consolidated financial statements have been prepared on the following basis:*

- The financial statements of Chemcel Biotech Limited and its subsidiary company Jetro Petro Biotech Pvt. Ltd have been combined on a line-by-line basis by adding together the book values of like items of assets, liabilities and expenses.
- Intra group balances and intra group transactions and resulting losses are eliminated in full.
- Subsidiaries are no longer consolidated from the date of disposal.

### ***Revenue Recognition***

Sales i.e., Sales includes Excise Duty, Cess, SHEC and Sales Tax.

All expenses and income are accounted for on accrual basis as per the requirements of the Companies Act except staff retirement benefits.

### ***Fixed Assets***

Fixed Assets are recorded at Cost. Cost is purchase cost, and in the case of Land, includes development cost incurred, together with all incidental cost of acquisition, borrowing costs and other related internal costs. Fixed Assets are shown Gross Block Less Depreciation.

### ***Depreciation***

Freehold land is not depreciated.

Other assets are depreciated on Written down value method in accordance with the rates prescribed in Schedule XIV to the Companies Act, 1956. But as per accounting standard, gross value of assets less depreciation to date are to be shown.

### ***Impairment Loss***

The company assets at each Balance sheet date whether there is any indication that any asset may be impaired and if such indication exists, the carrying value of such asset is reduced to its recoverable amount and a provision is made for such impairment loss in the profit and loss account. But there is no such type of asset during the year.

### ***Retirement Benefits***

Contribution to Provident fund accounted on accrual basis. Gratuity and Pension schemes are yet to be introduced.

### ***Miscellaneous and Preliminary Expenses***

Effective 01.04.2006, such expenditure is written off as incurred in accordance with 'AS-26 Intangible Assets', within 4 years.

### ***Deferred Tax***

Deferred tax is recognized on timing difference between taxable income and accounting Income that originated in one period and are capable of reversal in one or more subsequent periods

### ***Capital Work in Progress***

The Company acquired 2060.4 sq.yards Industrial Land at Kondapally to set up Bio diesel process plant.

**Profit & Loss**

Name of the subsidiary company	Financial year ending of the subsidiary	No. of equity shares held with its face value	Extent of holding	Profits/losses so far as it concerns the members of the holding company and not dealt within the holding company's accounts
Jetro Petro Biotech Pvt. Ltd	31.03.2008	3,000	60%	1,18 Lakhs

**Borrowing Costs**

Borrowing costs attributable to the acquisition and construction of the Qualifying Assets, which takes substantial period of time to get ready for its intended use, are capitalized as part of the cost of respective assets up to the date when such asset is ready for its intended use. Other Borrowing costs are charged to the Profit and Loss account.

**Valuation of Inventory**

Inventories of Spares, consumables, and components are valued at lower of cost and net realizable value. Cost represents purchase cost and other incidental costs, if any. Cost of Inventories is computed on weighted average / FIFO basis.

**Subsidy**

The Company opted to for the sales tax deferment scheme and the amount of sales tax payable to sales tax department is payable from the 14th year of deferment. The amount is shown as unsecured Loans and do not carry any interest. The Company is disputing the sales tax liability for an amount of Rs.837576/-. As it is disputing, no provision is made by the Company.

**Other Income**

Interest received shown as Other Income.

**Secured Loans**

The Company obtained Working Capital facility for an amount of Rs 4.97 Crores and Term Loan of Rs.1.31 crores from Union Bank of India, Vijayawada main Branch by giving the following securities.

Land Buildings, Plant, machinery, Debtors (Less than six months), stock of the Company and personal properties and Guarantee of Directors are given as Security.

The Company obtained Term Loan for an amount of Rs.36.79 lakhs from Kotak Mahendra Bank Ltd, Vijayawada by giving Kondapalli Site as Security.

**CHEMCEL BIOTECH LIMITED****Annexure - IV (Consolidated)****Notes on Accounts**

	Paticulars	(Rs.in lakhs) 31.03.08
a	Estimated amount of Capital commitments (Net of Advances)	
B	Excise Duty	0.00
ii.	Sales Tax Appeal pending with Hon'ble High Court, Hyderabad	8.38
c	Guarantee given to Banks	62.00



2. Additional information as required under paragraphs 3, 4C and 4D of Part II of Schedule VI to the Companies Act, 1956 are as under:-
- a. Consolidated Details for each class of goods manufactured, sold and stocks (As certified by the Management)

Particulars	For the period/year ended on 31.03.08
Particulars	Qty. (MT)
Capacity	
Licensed Capacity	
Installed Capacity	
- Liquids	1000 KL
- Granules	1000 MT
- Dusts	300 MT
Particulars	31.03.08
Liquids (in Lts)	
Opening stock	20283.2
Production/Receipts	582677.30
Closing stock	26169.25
Sales	576791.25
Granules (in Kgs)	31.03.08
Opening stock	6594
Production/Receipts	29454
Closing stock	48
Sales	36000
Dust (in Kgs)	31.03.08
Opening stock	1941.85
Production/Receipts	64368.80
Closing stock	544.65
Sales	65761

The company is not dealing with foreign currency.

1. In the opinion of the Board and to the best of their knowledge and belief the value on realization of the current assets, loans and advances, if realized, in the ordinary course of business would not be less than the amount at which they are stated in the balance sheet. The provisions for all known liabilities are adequate and not in excess of amount considered reasonably necessary.
2. The company has pledged the stocks, Fixed Assets to the bank for obtaining working capital loans from Union Bank of India. The working directors have also stood as guarantors for the amounts borrowed from bank.



## 3. Consolidated Directors Remuneration:

(Rs. in Lakhs)

PARTICULARS	31.03.08
Salary	30.63
Contribution to Provident Fund	0.72
Sitting Fee	0.32
Value of perquisites	
Total	31.67

## 4. Auditors' Remuneration:

Rs. in lakhs

PARTICULARS	31.03.08
Audit Fee	1.70
Consultancy on Taxation Matters	0
Other Professional Services	0
Reimbursement of Expenses	0
Total	1.70

5. Income tax assessment has been completed up to the assessment year 2004-05.
6. As the company's business activity falls within a single segment viz. 'Pesticides', the disclosure requirements of Accounting Standard 17 "Segment Reporting" issued by the Institute of Chartered Accountants of India is not applicable.
7. The company has availed working capital facilities from Union Bank of India, Vijayawada main branch. The balance outstanding in this account as at 31st March 2008 is about Rs.497.29 lakhs
8. Sundry Debtors / Creditors / Loans and Advances are subject to confirmation.
9. There are no amounts outstanding in respect of unpaid dividend.

## (a) Consolidated for Investments

(Rs. in Lakhs)

PARTICULARS	31.03.08
Total cost of quoted Investments	-
Total cost of unquoted Investments	-
Aggregate Market value of quoted Invt.	-

10. The income of the company is not dependent upon a single (domestic/foreign) customer.
11. Figures of previous periods and have been regrouped/rearranged, wherever necessary.
13. There are no adjustments which are brought out by the auditors and are not provided for.

We confirm that all notes to accounts, significant accounting policies and our Qualifications have been incorporated.



## CASH FLOW STATEMENT FOR THE YEAR ENDING 31.03.2008

Rs.in lakhs

A	<b>Cash Flow From Operating Activities</b>	<b>31.03.08</b>
	<b>Net(loss)/Profit Before Tax but after</b>	
	Exceptional /Extraordinary items	163.07
	<b>Adjustments for:-</b>	
	Depreciation	10.78
	Miscellaneous Expenditure Written off	1.19
	Provision for Tax	(38.88)
	Provision for FBT	(3.52)
	Any other non cash item	1.70
	<b>Operating Profit before Working Capital changes</b>	(28.73)]
	Adjustments for change in working capital:	
	(increase)/decrease in Sundry Debtors	63.46
	(increase)/decrease in Advances to Suppliers	379.31
	(increase)/decrease in Other Current Assets	(135.34)
	(increase)/decrease in Inventories	4.31
	increase/(decrease) in trade creditors & other Payables	161.80
	<b>Net Cash from Operating Activities</b>	149.94
<b>B</b>	<b>Cash Flow From Investing Activities</b>	
	Purchase of Fixed Assets	41.37
	Capital Work in Progress	(13.00)
	Purchase of Investments	28.37
	<b>Net Cash Used in Investing Activities</b>	
	Increase in Preliminary expenses	0.57
<b>C</b>	<b>Cash Flow From Financing Activites</b>	
	Proceeds from fresh issue of share capital	
	Net Proceeds from Long Term Borrowings	(0.12)
	Net Proceeds from Short Term Borrowings	57.68
	Deposits from Dealers	
	Dividend Paid	
	Net Cash used from Financing Activity	57.56
	Net increase/(decrease) in cash & cash equivalents(A+B+C)	13.02
	Cash & Cash Equivalents at the beginning of the year/period	1.27
	Cash & Cash Equivalents at the End of the year/period	14.29

**ANNEXURE VI****Consolidated Statement of Dividend paid for the period ending 31st March 2008****Rs.in Lakhs**

For the year ended	31.03.08
On equity shares	
No. of equity shares	105.18
Rate per centage	0
Bonus issue	
Amount of dividend (Rs in Lakhs)	0
Dividend tax (Rs in Lakhs)	0
Total pay out (Rs in Lakhs)	0

**ANNEXURE VII****Consolidated Statement of Accounting Ratios****(Rs in Lakhs)**

<b>Particulars</b>	<b>For the year ending on 31.03.08</b>
Profit before tax	163.07
Minority Interest	0.79
Profit Before Tax	163.86
Less: Provision for Current Tax	42.28
Profit after Current Tax	121.58
No. Of Equity Shares (in lakhs)	105.18
<b>EPS Basic / Diluted (Rs. Per Share)</b>	
-After Current Tax (Profit After Tax/ No.of Equity Shares)	1.16
Cash EPS(Profit After Tax+ Depreciation)/No.of Shares)	1.25
<b>Net Worth / NAV / Return on Net Worth</b>	
Profit After Tax	121.58
-Net Worth= Equity + Reserves - Misc. expenses to the extent of not written off	1328.87
Return on Net Worth %	
(Profit after tax/Net Worth)	9.10
Net Asset Value per Share (NAV)	
(Net Worth/ No. of Shares)	12.63



## ANNEXURE VIII

## Consolidated Capitalization Statement

(Rs in lakhs)

	Particulars	Pre Issue	Post Issue
1	Secured Loans	665.64	162.84
2	Un Secured Loans	45.93	45.93
3	Total Debt	711.57	208.77
4	Less : Short Term Debt	665.64	162.84
5	Total Long Term Debt	45.93	45.93
	<b>Share Holders Funds</b>		
6	Share Capital	1051.82	2591.82
7	Reserves & Surplus	277.32	1201.32
8	Total Share Holders Funds	1329.14	3793.14
	<b>Long Term Debt/ Equity Ratio (5 / 8)</b>	<b>0.03</b>	<b>0.01</b>

## ANNEXURE-IX - Consolidated Tax Shelter Statement

(Rs in Lakhs)

PARTICULARS	31.03.08
Tax Rate ( incl. Surcharge & Education Cess)	33.66%
Profit as per Profit and Loss Account	165.05
Tax at Notional Rate	38.88
<b>Adjustments</b>	
Difference between Tax depreciation & Book Depreciation	0.34
Other Adjustments	49.52
Net Adjustments	49.86
Tax Savings thereon	16.78

## ANNEXURE X (CONSOLIDATED)

## Details of Other Income

(Rs in Lakhs)

Particulars	For the Period ending on 31.03.08
Other Interest	0.13
<b>Total</b>	<b>0.13</b>

## ANNEXURE - XI

## Consolidated Sundry Debtors

(Rs. in lakhs)

Particulars	For the Period ending on 31.03.08
	181.45
Other Debts	944.71
Total	1126.16
Less : Provision for Doubtful Debts	0
Total	1126.16

Note: None of the Debtors is related to the Directors / Promoters of the Company.



## ANNEXURE - XII

## Consolidated Loans and Advances ( Unsecured considered Good)

Particulars	For the period / year ended 31.03.08
Advances recoverable in cash or in kind or for value to be received	702.76
Other Advances	720.51
Deposits	1.53
Total	1424.80

## ANNEXURE XIII

## Consolidated Statement of Unsecured Loans

(Rs in Lakhs)

Particulars	For the Year ending on 31.03.08
A From Promotor/ Directors	
B From Associate/group Companies	
C Others	
-Sales Tax Deferment	36.42
Others	9.51
<b>Total</b>	<b>45.93</b>

## ANNEXURE - XIV

## Consolidated Statement of Existing Secured Loans:

Particulars of Loan	Bank	Nature of Loan	Sanctioned Amount	Amount out standing as at (31.12.07)	Rate of Interest %	Repayment of terms	Securities Offered
Working Capital Facility	Union Bank of India, Vijayawada Main Branch	Working Capital Loan	530.00	497.28	12.00	On Demand	Hypothication of stocks, raw marterials, finished goods of pesticides, fungicides and bio fertilizers and book debts not less than 90 days and personal guarantee of Directors
Short Term Loan	Union Bank of India Vijayawada Main Branch		120.00	131.56	12.00	On Demand	Same as above
Term Loan	Kotak Mahendra Bank Ltd, Vijayawada	Term Loan	38.80	36.79	18.46	Monthly installment	Hypothication of Kondapalli Site
Car Loan	Laksmi General Finance Ltd	Term Loan	3.99	0.55		Monthly installment	Hypothication of Car





## CHEMCEL BIOTECH LIMITED

## Particulars of paid secured loans availed in the previous 5 years (Consolidated)

(Rs in lakhs)

	Particulars	For the period/year ended on
	<b>31.03.08</b>	
a.	Term Loans	
	Kotak Mahendra Bank Ltd	36.79
	Union Bank of India	131.56
b.	Working Capital Loans	
	Andhra Bank	-
	Union Bank of India	497.29
c.	Sundaram Finance Limited	0.55
	<b>Total</b>	<b>666.19</b>

There are no re-schedulement, pre-payment, penalties, default of the above loans.

**Other collateral Securities offered**

1. Three stored industrial building (2 blocks) constructed in an extent of 1849.02 sq. yards at R.S.No.183/1, Asst.No.3302, D.No.16-130/12, III cross road, JRD Tata industrial estate, Kanuru, Penamaluru Mandal, Krishna Dt., in the name of M/s Chemcel Bio-Tech Ltd. Valued Rs.118.00 lakhs.
2. 493.28 Sq.yards of residential vacant site situated at R.S.No.460, plot No.28 (Nearest D.No.54-20/4-11), Gurunanak colony, Vijayawada in the name of Mr. K .T. Vijaya Kumar valued Rs.49.39 lakhs.
3. Plot No.101, (Plinth Area 44.37 Sq .Yards) at R.S.No.10/8, Sindhur Appts, Gayatrinagar, Vijayawada. In the name of Mr.K.Balakrishna Rao, valued Rs.14.59 lakhs.
4. 393.30 Sq.Yards of residential sites along with RCC framed structure at R.S.No. 43/1(Part), Asst.No.151235, nearest D.No.42-4-121/2; Temple street, Mutyalampadu, Ramakrishnapuram, Vijayawada. In the name of Sri.M.V.R.Sastry, valued Rs.22.39 lakhs.
5. 888.88 Sq.Yards of residential vacant site situated at S.No.160, Plot No.70,71,80 and 81 at Kapra, near Hyderabad, Kesara Mandal, R.R District, owned by Sri.K.T.Vijaya Kumar, valued Rs.19.56 lakhs.

## Personal Guarantee

Personal guarantee of all the Directors in their individual capacity and Mr. M. V. R. Sastry.

## ANNEXURE XV

Statement of Transactions with related parties in preceding 3 years (Consolidated)

**Key Management Personnel (Directors Transactions with them)**

K. BALA KRISHNA RAO  
K.T. VIJAY KUMAR  
K.C.S PRASAD

(Rs. In Lakhs)

PARTICULARS	For the Year ending on 31.03.08
Remuneration	31.67
Dividend	0
<b>Total</b>	<b>31.67</b>

Relatives Of Key Management Personnel and Transactions with them

K. SUJATHA

(Rs. In Lakhs)

PARTICULARS	For the Year ending on 31.03.08
Car Hire Charges	0.06



K.SRINIVASA PRASAD

(Rs. In Lakhs)

PARTICULARS	For the Year ending on 31.03.08
Salary paid	1.50

JETRO PETRO BIOTECH PVT. LTD

(Rs. In Lakhs)

PARTICULARS	For the Years ending March 31				
	2008	2007	2006	2005	2004
Advance given	539.41	-	-	-	-

**JETRO PETRO BIOTECH PVT. LTD**

The Holding Company Chemcel Biotech Limited given advance of Rs.5,39,41,500/- to subsidiary company for seed supply.

2. Financial Information of subsidiary company is attached.

**Details about Companies/Firms from which promoters have disassociated during the last three years**

Our promoters have not disassociated from any Companies/ Firms in last three years.

Companies for which an application has been made for striking off name

There are no companies associated with our Company, Our Promoters and its directors, for which an application has been made with the Registrar of Companies for striking off the names of those companies.

**Changes in Accounting Policies During Preceding Three Years**

There have been no changes in accounting policies of our Company, during preceding three years.

**NOTES ON ACCOUNTS****Basic of Accounting**

The financial statements are prepared under the historical cost conventions on the basis of going concern and as per applicable Indian accounting standards and are based on the accrual basis of accounting.

**Revenue Recognition**

All expenses and income are accounted for on accrual basis as per the requirements of the Companies Act except staff retirement benefits.

**Miscellaneous and Preliminary Expenses**

Expenses incurred before the formation of the Company are shown as preliminary expenses.

**Loans and Advances**

\* It includes the amount paid to the farmers for advance to supply the Bio Diesel seed.

Value of Imports and indigenous materials consumed	NIL
Value of imports on GIF basis	NIL
Expenditure in foreign currency	NIL
Earnings in foreign exchange on cash basis	NIL
Figures of previous year have been re-grouped wherever necessary	NIL

**T. NEHRU**

Chartered Accountant

Membership No.15207

Place: VIJAYAWADA

Date : 12.07.2008



### 3. MANAGEMENT DISCUSSION AND ANALYSIS OF FINANCIAL CONDITION AND RESULTS OF OPERATIONS

Investors should read the following discussion of our financial condition and results of operations together with the restated audited financial statements and the notes to those statements included in this Prospectus. The following discussion is based on our Company's audited financial statements and on information available from other sources. Our Company's fiscal year ends on March 31st of each year, so all references to a particular fiscal year ends on March 31st of that year.

#### Overview

Our Company was incorporated on September 29, 1995 with the main objective of manufacturing of Agro Chemicals. Later on started producing bio-fertilizers.

Our Company's main products are in three forms viz., Liquids, granules and dusts. Individual capacities of these products are as under:

Liquids	1000 KL / per year
Granules	1000 MT / per year
Dusts	300 MT / per year

Our Company has CIB registrations for 34 products to manufacture pesticides for crops i.e., Paddy, Cotton, Sugarcane, Turmeric, Chillies, Pulses, Vegetable etc., of which it is currently manufacturing 17 products.

Our Company has been predominantly concentrating in coastal districts of Andhra Pradesh, where paddy is grown extensively.

The promoters of our Company are associated with the pesticides industry for more than 30 years. They have developed a dedicated network of 350 authorised direct dealers, 550 retailers and 18 distributors across 5 districts of coastal Andhra Pradesh.

Considering the opportunities in the field of production and supply of alternative fuels to petroleum based fuels, our Company has decided to diversify into manufacture and supply of bio-diesel. Bio-diesel is an alternative fuel which is derived from Jatropha seeds. In order to have uninterrupted supply of Jatropha seeds, our Company has entered into seed supply agreement with seed supplier M/s Jetro Petro Biotech Pvt Ltd.

The world is experiencing an energy crisis. The demand of Diesel (H.S.D.) is projected to grow from 39.81 MMT in 2001-02 to 52.32 MMT in 2006-07 @ 5.6% per annum. Our crude oil production as per the Tenth plan working group is estimated to hover around 33-34 MMT per annum even though there will be increase in gas production from 86 MMSCMD (2002-03) to 103 MMSCMD in (2006-07). Only with joint venture abroad there is a hope of oil production to increase to 41 MMT by (2016-17). The gas production would decline by this period to 73 MMSCMD. The increasing gap between demand and domestically produced petroleum is a matter of serious concern. At present 70% of our oil requirement is met through imports. This provides huge potential for alternative fuels. The search for alternative fuels has been on for long. Agriculture and industry utilize the diesel-powered engine for a multitude of purpose, but the supply of petroleum derived diesel fuel is limited. The depletion in world petroleum reserves and uncertainty in petroleum supply due to political and economical reasons stimulated the search for alternative sources for petroleum-based fuels especially for diesel fuels. Many alternate sources of energy are been considered. One of the viable alternatives is Bio-Diesel. Bio Diesel is the name of a clean burning alternative fuel produced from domestic, renewable resources. Bio diesel contains no petroleum, but it can be blended at any level with petroleum diesel to create a bio-diesel blend. Bio-diesel enjoys certain advantages over other alternative sources. It can be used in compression ignition (diesel) engines with no major modifications. Bio diesel is simple to use, biodegradable, nontoxic, and essentially free of Sulphur and Aromatics. To tap the huge potential in the Bio-deisel market, our Company has planned to enter the Bio-diesel industry.

Our Company is proposing to set up a 20 TPD bio diesel manufacturing unit.

**Significant Developments subsequent to the Last Financial year**

The Directors of our Company confirm that in their opinion, no circumstances have arisen since the date of last financial statements as disclosed in the Prospectus and which materially and adversely affect or is likely to effect the trading or profitability of our Company, or the value of its assets or its ability to pay its liabilities within the next twelve months.

**Key Factors influencing results of operations**

The key factors influencing our results of operations, profitability and cash flow are listed below:

- The fortunes of Agro Chemical industry are influenced and closely linked to the growth and development of overall agricultural sector, which in turn is dependent on monsoons.
- High working capital requirement of the Agro chemical division due to its seasonal nature and long credit period given to farmers.
- Entry of other players or significant improvement in the functioning of existing players.
- Any change in government rules and regulations relating to the industries in which our Company is operating.
- Emergence of new competitive products with regard to Agro chemical industry.

**Our Growth Path**

The table below sets forth information regarding our income, expenditure and profits for the indicated period.

Statement of Profit and Loss Account as Re-Styled

(in Lakhs)

Particulars	For the year ended March 31				
	2008	2007	2006	2005	2004
<b>Income</b>					
Sales	2457.82	2333.69	2137.03	1290.51	1284.14
Other income	0.13	0.93	8.43	0.27	-4.09
Increase / (Decrease) in stocks	4.31	13.04	34.62	-66.97	57.91
<b>Total Income</b>	<b>2462.26</b>	<b>2347.66</b>	<b>2180.08</b>	<b>1223.81</b>	<b>1337.96</b>
<b>Expenditure</b>					
Manufacturing expenses	1862.49	1714.19	1528.30	603.60	617.87
Payment to employees	57.33	48.33	51.31	46.34	54.80
Other Expenditure	83.64	91.72	124.19	183.55	221.98
Selling expenses	174.74	273.98	330.75	305.99	401.31
Interest	107.18	60.03	41.51	23.64	10.45
Depreciation	10.78	12.47	12.84	14.20	14.42
Preliminary exps w/off	1.05	1.05	1.05	0.47	0.17
<b>Total Expenditure</b>	<b>2297.21</b>	<b>2201.77</b>	<b>2089.94</b>	<b>1177.79</b>	<b>1321.00</b>
Profit before tax	165.05	145.89	90.13	46.02	16.96
Current tax	42.4	52.47	14.46	27.64	8.55
Deferred tax	0.11	0.20			
<b>Profit after tax</b>	<b>122.76</b>	<b>93.62</b>	<b>75.68</b>	<b>18.39</b>	<b>8.41</b>
Income tax relating to earlier year					
<b>Net profit</b>	<b>122.76</b>	<b>93.62</b>	<b>75.68</b>	<b>18.39</b>	<b>8.41</b>

**Comparison of Fiscal 2007 with 2008****Net Sales :**

During the fiscal 2008, our Company has recorded a turnover of Rs.2457.82 Lakhs which is 5.32% over and above the previous year turnover of Rs.2333.69 Lakhs.

**Manufacturing Expenses :**

Manufacturing expenses are at Rs.1862.49 Lakhs for the fiscal 2008 as against Rs. 1714.19 Lakhs for 2007. This is of 8.65% increase over previous year.

**Staff Cost :**

The staff cost has gone up from Rs.48.33 Lakhs in 2007 to 57.33 Lakhs in 2008, recording a rise of 18.62%.

**Administrative & Other Expenses :**

Our Company continued adopting cost saving measures and made a saving of about Rs.8.08 Lakhs under this head of expenses during the year under question. These expenses accounted for Rs.83.64 Lakhs for the fiscal 2008 as against Rs 91.72 Lakhs during fiscal 2007 and Rs.124.19 lakhs in 2006.

**Selling & Distribution expenditure :**

These expenses are reduced from Rs.273.98 Lakhs to Rs.174.74 Lakhs. These expenses are reduced for the second consecutive year.

**EBITD**

EBITD has improved by more than 29.45% over the previous year from Rs.219.44 Lakhs to Rs.284.06 Lakhs due to increased turnover and cost saving measures.

**Comparison of Fiscal 2006 with 2007****Net Sales :**

During the fiscal 2007, our Company has recorded a turnover of Rs.2333.69 Lakhs. This is about 9.2% increase over previous year turnover of Rs.2137.03 Lakhs. The increase in sales was due to launch of new products .

**Manufacturing Expenses :**

Manufacturing expenses are at Rs.1714.19 Lakhs for the fiscal 2007 as against Rs.1528.30 Lakhs for 2006. This is about 12% increase over previous year.

**Staff Cost :**

Our Company made some small savings in the staff cost. The cost has been reduced to Rs.48.33 Lakhs from 51.31 Lakhs.

**Administrative & Other Expenses :**

Our Company adopted some cost saving measures and made a saving of about Rs.32 Lakhs. These expenses accounted for Rs.91.72 Lakhs for the fiscal 2007 against Rs 124.19 Lakhs during fiscal 2006.

**Selling & Distribution expenditure :**

These expenses are substantially reduced from 330.75 Lakhs to Rs 273.98 Lakhs.

**EBITD**

EBITD has improved by more than 50% over the previous year from Rs. to 145.53 Lakhs to Rs.219.44 Lakhs due to higher turnover and cost saving measures.

**Changes in Accounting Policies**

From the FY 2006-07, our Company has changed its policy on sales returns pertaining to previous FY. As per the earlier policy, our Company was disclosing the gross turnover and the sales returns were shown separately under the head - Manufacturing expenses. From the FY 2006-07, the sales returns are deducted



from the current turnover and only net turnover is being disclosed. This change in policy does not affect profitability of our Company .

### **Comparison of Fiscal 2005 with 2006**

Our Company has done extremely well during the Fiscal 2006. Our Company has expanded its marketing network to new areas is the main reason for such all round growth. Some of the new products introduced during the fiscal also contributed to this phenomenal growth.

#### **Net Sales :**

During the fiscal 2006, our Company's net sales are increased by 72% over the previous year. It has recorded a turnover of Rs.2115.84 Lakhs compared to the previous year sale of Rs.1229.08. Increased market, introduction of new products, Consistent Quality are some of the reasons for the growth.

#### **Manufacturing Expenses :**

These expenses are at Rs.1528.30 Lakhs which is higher by 153% over the previous year. In order to promote sales in the new markets and also to promote new products, our Company has adopted penetration costing technique. It has given good discounts to the dealers and earned minimum profits.

#### **Staff Cost :**

The additional staff for the new markets increased staff cost by Rs.4.97 lakhs. The cost for the fiscal 2006 is Rs.51.31 Lakhs compared to the previous year of Rs.46.34 Lakhs.

#### **Administrative & Other Expenses :**

These expenses are lower by 16% over the previous year. The management has adopted some cost control measures , as a result there are savings under this head. These expenses are at Rs.103.00 Lakhs for the Fiscal 2006 when compared to the previous year expenditure of Rs.122.12 Lakhs.

#### **Selling & Distribution expenditure :**

These expenses are increased by 8% over the previous year. The additional expenditure incurred for promoting new products and for entering into new markets .

#### **EBITD**

Earnings before Interest, Tax & Depreciation has improved by more than 71% over the previous year. It is at Rs.102.98 Lakhs for the fiscal 2006 against Rs.60.22 Lakhs for 2005. The substantial increase in EBITD was due to higher sales and cost saving in expenses. over all good performance by our Company lead to such a huge jump.

#### **Seasonality**

Our Company business is seasonal to the extent that pesticides are sold during the period June- November for Kharif crops and during the period December-March for Rabi crop. Our Company has been expanding in the Rayalaseema / Telangana regions and other southern states to eliminate this dependence. This would decrease the impact of seasonality on our Company financial.

#### **Any significant dependence on a single or few suppliers or customers**

The existing business of our Company does not depend significantly on few suppliers or customers. However, the bio-diesel project is dependent on a single supplier and concentrated customers. Our Company would be acquiring Jatropha Curcas for the bio-diesel project from M/s Jetro Petro Biotech Pvt Ltd., However, our Company can also purchase the seeds in the open market. Our Company would be selling the diesel to IOC, BPL and the like.

#### **Known trends and uncertainties that have had or are expected to have a material impact on sales, revenues and income from continuing operations**

No known trends are envisaged that are expected to have material impact on income from continuing operations. Uncertainties such as low pest incidence and dry spells can affect our business.



Future changes in relationships between costs and revenues in case of events such as future increase in labour or material cost or prices that will cause material change are known

There are no such changes in relationship between cost and revenues.

**Status of any publicly announced new products or business segment**

Our Company has undertaken a bio-diesel project for the manufacturing of Bio-diesel. The project is expected to commence its commercial production in Jan,2009 .

**Competitive conditions**

Our Company has been strengthening its position in the product lines in which it is operating by offering variety and quality consistently, through our in-house quality checks. Our Company has distributors and dealers, representing our Company all over India which is not the case with many other companies. We are offering wide range of, a competitive advantage which again is not available with many others. These conditions provide us an edge in the market over our competitors. For details please refer to section titled "Business Overview".

**SECTION VI : LEGAL AND OTHER INFORMATION****1. OUTSTANDING LITIGATION AND MATERIAL DEVELOPMENTS**

Except as stated below there are no outstanding litigation, suits, criminal or civil prosecutions, proceedings or tax liabilities against our Company, our subsidiaries, our directors, our Promoter and Promoter Group Companies and there are no defaults, non payment of statutory dues, over-dues to banks/financial institutions/small scale undertaking(s), defaults against banks/financial institutions/small scale undertaking(s), defaults in dues payable to holders of any debenture, bonds and fixed deposits and arrears of preference shares issued by the Company, defaults in creation of full security as per terms of issue/other liabilities, proceedings initiated for economic/civil/any other offences (including past cases where penalties may or may not have been awarded and irrespective of whether they are specified under paragraph (I) of Part 1 of Schedule XIII of the Companies Act) other than unclaimed liabilities of the Company and no disciplinary action has been taken by SEBI or any stock exchanges against our Company, our Promoter or Directors.

**1) Cases filed against our Company:**

- a) Civil Cases

Nil

- b) Indirect Tax matters

- i) Sales Tax Proceedings - AY 2002-2003

The matter pertains to the Assessment Year 2002-2003 and the assessment order dated March 25, 2006 passed by the Commercial Tax officer, Benz Circle, Vijaywada ("CTO"). The Commercial Tax Officer had alleged that there was an element of escaped turnover from tax net in the hands of the Company.

The CTO by an order dated March 25, 2006 has assessed the total tax payable to be Rs. 3.21 million out of which the Company has already paid Rs.2.37 million.

Our Company has filed a Writ Petition (No. 16932/2003) before the Andhra Pradesh High Court against the above order. The Andhra Pradesh High Court has granted a stay under an order dated September 13, 2006 in WPMP 23787/2006 against the order of the CTO demanding Rs.0.84 Million. The matter shall come up for hearing in the normal course.

**c) Direct Tax matters**

For the AY - 2005-06

- i) Our Company has filed an Appeal under Section 246 of the Income Tax Act, 1962 before the Commissioner of Income Tax against the Order passed by the Additional Commissioner dated December 31, 2007. The Additional Commissioner has, inter alia, made some additions/disallowances pertaining to the following:

	(Rs.)
Disallowance of excess depreciation	30,000
Disallowance of interest	6,63,624
Addition of Chit Dividend	54,967
Addition of Unexplained Share Application money	33,48,000

Pursuant to the above additions/disallowances along with interest and penalties, the tax liability of our Company in terms of the above order amounts to Rs.18,85,716. Our Company has already paid an amount of Rs.2.85 Lakhs leaving a balance of Rs.16.00 Lakhs.

- d) Proceedings under Section 138 of the Negotiable Instruments Act, 1881

- i) Coromandel Fertilisers Limited have filed a complaint bearing case no. 67 of 2008 on March 12, 2008 before the Addl. Chief Metropolitan Magistrate, Secunderabad under section 138 read with 142 of Negotiable Instruments Act, 1881. Coromandel Fertilisers Limited has alleged a cheque dishonour of an amount of Rs.5,00,000. The matter shall come up for hearing on October 4, 2008.





2) Cases filed by our Company

a) Civil Cases

- i) Our Company has filed Suit bearing No. 12 of 2007 before the II Addl. Senior Civil Judge, Vijayawada against Rallis India Limited in the Court of Senior Civil Judge, Vijaywada for an injunction against Rallis India Limited and its officials from making defamatory statements against our Company. Our Company moved the Court as Rallis India Limited and its officials made certain allegations against the Company with various government authorities including Ashika Capital Limited, the merchant bankers of this Issue.

The Company filed interim application in the above Suit and the Hon'ble Judge passed an order dated March 5, 2007 restraining Rallis India Limited and its officials from bald proclamations, allegations or addressing any letters to any concern defaming the credentials of our Company.

b) Criminal Cases

- i) Our Company filed a criminal complaint (No.535/2007) before the I Addl. Chief Metropolitan Magistrate Court, Vijayawada against Rallis India Ltd and its officials under section 499 and 500 of the Indian Penal Code for criminal defamation against our Company. The Court issued summons against the certain officials of Rallis India Limited against which Rallis India preferred a Criminal Petition (No. 3917 of 2007) before Hon'ble High Court of Andhra Pradesh to quash the summons and obtain stay on the proceedings before the trial court. The Hon'ble High Court of Andhra Pradesh passed an order granting stay on the proceedings of the Trial Court.

3) Litigation against Promoters:

a) Civil Cases:

NIL

b) Criminal Cases

- i) Rallis India Ltd. has filed an FIR (Crime No. 33/07) against our Promoter Mr. K.T.Vijay Kumar under Section 406, 408, and 420 of the IPC in the S.N. Puram police station. Police investigation resulted in to the finding that the whole complaint is not true and is a "Mistake of Fact". The Court of Chief Metropolitan Magistrate, Vijayawada has given the order as 'Mistake of Fact' and discharged the FIR vide order dated 25.03.08. Hence the case stands closed.

4) Litigation against Directors:

NIL

5) Litigation against Group Company/ Associate Concerns:

NIL

6) Litigations / Disputes involving Securities related offences, including penalties imposed by SEBI or any other securities market regulator in India or abroad:

NIL

7) Litigations involving statutory or other offences, including penalties imposed by any regulatory authority in India or abroad (present or past):

NIL

8) Litigation in relation to labour laws, and employee related cases:

NIL

9) Other Litigation:

- a) Non payment of statutory dues or dues to Banks / Institutions



Statutory Dues : Our Company has delayed payment of statutory dues to the extent of Rs 52.00 lakhs. Our company has delayed payment of Rs 39.90 lakhs to the Income Tax department and Rs 12.05 lakhs to the excise department for the FY 2006-07 .

b) Overdue interest/ principal as on current date.

A short term loan of Rs 120 lakhs was sanctioned by Union Bank of India, Vijayawada branch, vide their letter dated November 08, 2006 for meeting the expenses related to the proposed Bio diesel Project as mentioned in the objects of the issue. The repayment of this loan is one of the objects of the issue. For details please refer to the "objects of the issue" on page no.28 of this prospectus. Our Company has been servicing the interest component but as the IPO was delayed the repayment of Principal has become overdue . We have requested Union Bank of India to extend the repayment period till October 2008 or completion of IPO process whichever ever is earlier . The request is under active consideration of the Bank. The present outstanding in the account is Rs 119.20 lakhs.

10) Our Company, promoters, directors or other ventures of the promoters and companies with which they are associated with have not been prohibited from accessing the capital markets under any order or direction passed by SEBI and no penalty has been imposed at any time by any of the regulators in India or abroad.

11) Our Company, promoters, directors or other ventures of the promoters and companies with which they are associated with have not been prohibited from accessing the capital markets under any order or direction passed by SEBI and no penalty has been imposed at any time by any of the regulators in India or abroad.

**ALLEGATION:** Mr Manoj Chaperia P.O. pochamba, Giridih, Jharkhand vide his letter dated June 10, 2008, addressed to Allbank Finance limited, our Lead Mnager to the issue has alleged that he had suffered financial loss on account of Mr Vijaya Kumar, Managing Director of our company. He has also alleged that a complaint case bearing no 1925 was filed before CJM, Jamshedpur and an FIR was also lodged in police station. Neither Our Company /nor Mr Vijaya Kumar have entered into any transactions with Mr Chaperia and no notice under the above compliant /FIR has been received till now. Our Lead Manager vide their letter dated June 13, 2008 have requested Mr Chaperia to provide the details of the transactions Mr Chaperia had with our Company /Mr Vijaya Kumar and the documentary evidence of the alleged case no 1925 and also the FIR copy. Till now no reply has been from received by Allbank Finance Limited. Copies of the allegation of Mr Chaperia and letter of our lead Manager are included as the material documents.

**Contingent liabilities of our Company as of March 31, 2008:**

Contingent liabilities of our Company as of March 31, 2007 and March 31, 2008 as per the Audited Financial Statement are as follows:

(Rs. In Lakhs)

PARTICULARS	As At	
	Mar 31, 2007	Mar 31, 2008
Claims against our Company not acknowledged as debts :		
i. Sales Tax Appeal pending with 'on'ble High Court, Hyderabad	8.38	8.38
ii. Guarantee given to Banks	62.00	62.00

**Material Developments**

**Our company has purchased 30000 equity shares of face value of Rs 10 each of M/s Jetro Petro Biotech Private Limited ( JPBPL) for a consideration of Rs 300000 which constitute 60% of JPBPLits present share holding.**

There are no material developments after the date of the last audited financials as on 31st March, 2008, which may materially affect the performance, or prospects of our Company. For details of the company please refer to page no 144 .

As per the opinion of the Directors, no circumstances have arisen since the date of last financial statement disclosed in the Prospectus that materially and adversely affect or are likely to effect the trading or profitability of our Company, the value of its assets, or its ability to pay liabilities within the next twelve months



## 2. GOVERNMENT APPROVALS / LICENSING ARRANGEMENTS

Our Company has received all the necessary permissions and approvals from the Government and various non- Government agencies for conducting its agrochemicals business. No further approvals from any Government Authority are required by our Company to undertake the activities in the agrochemicals business of the Company save and except those approvals, which may be required to be taken in the normal course of business from time to time. As regards the bio-diesel business of the Company, the Company has made certain applications to appropriate government authorities. Certain other approvals shall be obtained on or before the commissioning of the project. It must be understood that in granting approvals, the Government of India and Reserve Bank of India does not undertake any responsibility for the financial soundness of the undertaking or for the correctness of any of the statements made or opinions expressed in this regard.

The following statement sets out the details of licenses, permissions and approvals taken by our Company under various Central and State Laws for carrying out its business. Those Government Licenses and approvals which have specific validity period have been disclosed hereunder and all other approvals /licences / registrations have no validity period and shall be in force till they are suspended/cancelled by the concerned Authorities .

Nature of Registration/License	Issuing Authority	Approvals received -Ref.No	
		Registration/License no.	Valid till
Certificate of Incorporation	Registrar of Companies, Andhra Pradesh	No. 01-21888, dt.29.09.1995.	One time Registration
Fresh Certificate of Incorporation with change in Name from 'Chemcel Products Limited' to "Chemcel Bio-Tech Limited"	Registrar of Companies, Andhra Pradesh	RAP/TA.VI/Sec.21/21888/T dated 4th January 2001	NA
Permanent Registration Certificate	Department of Industries, Government of Andhra Pradesh	No. 011109069 dated 23.06.1998	One time Registration
Factory License	Inspector of Factories	No. 42704 dt.12.01.2000	One time Registration
Value Added Tax	Commercial Tax Officer, Commercial Taxes Department, Government of Andhra Pradesh	No. 28420156124, dated 27.03.2005	One time Registration
Consent under section 25/26 of Water & Air (prevention and control of pollution) Act, 1974	Andhra Pradesh Pollution Control Board	K-790/PCB/RO-VJA/W/2007-1719, dated 28.02.2007	31.01.2011
Permanent Account Number	Commissioner of Income Tax, Vishakhapatnam, Andhra Pradesh	AAACC8998C	NA
Central Excise Registration	Superintendent of Central Excise, Vijayawada.	No. AAACC8998 CXM001, dated 14.02.2002.	NA
Under the section 7(1) 7(2) of the Central sales tax, 1956.	Sales Tax Department, Government of Andhra Pradesh	CST No.VJ2/07/2/1765/96-97 dated 26.05.1998.	NA
Plant protection quarantine and storage.	Directorate of plant protection quarantine and storage, Haryana	No.17-184/02-CIR, dated 10th October 2002.	NA



License to Manufacture Insecticides	Commissioner & Director of Agriculture, Andhra Pradesh	No. 27/98-99, dated 17.02.1998	31.12.2009
Registration certificate to manufacture of Excisable Goods	Superintendent of Central Excise	E.C.C.No. 2202012692 dated 02.04.1998	One time Registration
Provident Fund Registration	Regional Provident Fund Commissioner, Guntur, Andhra Pradesh.	No.AP/39798, dated 28.03.2002	One time Registration
Importer Exporter Code	DGFT, Ministry of Commerce, GoI	IEC Code No. 0906002401, dated 25.05.2006	One time Registration
Tax Deduction Account Number	Income Tax Department	HYDC01810E dated 02.10.2004	One time Registration
Methanol and storage of the same in the manufacturing process of Bio Diesel	Prohibition & Excise Superintendent	Rc.No.322/2006/A7, dated 02.07.07	31.03.2009
Certificate of Registration of Insecticides Under Section 9(1) of the Insecticides Act 1968. (Department of Agriculture & Co-operation), Directorate of Plant protection, quarantine and storage, N.H.IV. Faridabad	Hexaconazole 5% EC	CIR - 37260/2001-HEXOCONAZOLE (EC) - 94, dt.14.02.02	Not applicable
	Lambdacyhalothrin 5%EC	Cir - 43,227/2003 - LAMBACYHALOTHRIN (EC) (230) - 120. dt.04.03.03	Not applicable
	Hexaconazole 5% SC	CIR- 46,211/ 2003 - HEXACONAZOLE (SC) (238) - 227, dt.10.07.03	Not applicable
	Chlorpyriphos 50% + Cypermethrin 5% EC	CIR - 45, 166 /2003 CHLORPYRIPHOS + CYPERMETHRIN (EC) (237) - 2649, dt.15.07.03	Not applicable
	Acetamiprid 20% SP	CIR - 46212/2003- ACETAMIPRID (SP) (238) - 126, dt.10.07.03	Not applicable
	Ethion 40% + Cypermethrin 5% EC	CIR - 45, 222/2003 - ETHION + CYPERMETHRIN (EC) (237) - 766, dt.18.07.03	Not applicable
	Copperoxychloride	CIR - 38, 422 ( 219) / 2002/ COPPEROXY CHLORID (W.P.) - 789, dt.27.06.02	Not applicable
	Tricyclazole	CIR - 42, 632/2002 - TRICYCLAZOLE, (W.P.) (227) - 81, dt.18.11.2002	Not applicable
	Propiconazole	CIR - 42, 633/2002 - PROPICONAZOLE (EC) (227) - 78, dt.18.11.02	Not applicable
	Lambda Cyhalothrin 2.5% EC	CIR-43, 228/2003-LAMBDA CYHALOTHRIN, (EC) (230 - 121, dt.04.03.03	Not applicable



	Imidacloprid 17.8% SL	CIR - 40761/2002 - IMIDACL-OPRID(SL) (223)- 261, dt.10.09.02	Not applicable
	Dicofol	CIR - 26,230/97/DICOFOL (EC)-349, dt.24.12.97	Not applicable
	Fenvalerate	CIR-25,846/97/FENVALERATE (EC)-1260, dt.08.07.97	Not applicable
	Dimethoate	CIR- 27,512/97/ DIMETHOATE (EC)- 826, dt.23.03.98	Not applicable
	Carbendazim	CIR - 27,872/98/CARBENDAZIM ( WP)- 570, dt.31.03.98	Not applicable
	Ethion	CIR - 25, 564/ 97/ ETHION (EC) - 346, dt.15.05.97	Not applicable
	Endosulfan	CIR - 27, 532/97/ ENDOSULFAN (EC) - 1693, dt.17.03.98	Not applicable
	Monocrotophos	CIR - 25, 311/ 97/ MONOCROTOPHOA(SL)-1267, dt.31.03.97	Not applicable
	Cypermethrin 25% EC	CIR- 25,848/97/CYPERMETHRIN (EC) -1458, dt.04.06.97	Not applicable
	Acephate	CIR- 25, 845/97/ ACEPHATE (SP)-486, dt.08.07.97	Not applicable
	Cypermethrin 10% EC	CIR- 25,312/97/ CYPERMETHRIN(EC)-1423, dt.31.03.97	Not applicable
	Chlorpyrifos	CIR-25,844/97/CHLORPYRIFOS(EC)-853, dt.04.07.97	Not applicable
	Quinalphos	CIR-25,847/97/ QUINALPHOS(EC)-1081, dt.08.07.97	Not applicable
	Indoxacarb	CIR-53,909/2006-INDOXACARB(SC)(263)-274, dt.06.07.06	Not applicable
	Azadirachtin	CIR-34,276/2000/ AZADIRACHTIN(EC)-384, dt.18.01.2000	Not applicable
	Dichlorvos	CIR-34,608/2001/ DICHLOROVOS(E.C.)-774, dt.20.02.01	Not applicable



	Validamycin	CIR-41,891/2002-VALIDAMYCIN (I) (225)-26, dt.23.12.02	Not applicable
	Imidacloprid	CIR-40760/2002-IMIDACLOPRID(WS)(223)-260, dt.10.09.02	Not applicable
	Chlordyriphos	CIR-36017/2001-CHLORDYRIPHOS (GR) - 2114, dt.31.03.01	Not applicable
	Garbofuran	CIR-36,332/2001-CARBOFURAN(CG)-461, dt.31.03.01	Not applicable
	Cartap Hydrochloride	CIR-48,897/2004-Cartap Hydrichloride (GR)(246)-604, dt.05.10.04	Not applicable
	Mancozeb	CIR-45,211/2003-Mancozeb(WP) (237)-869, dt.17.07.03	Not applicable
	Triazophos	CIR-45,283/2003-Triazophos (EC) (237)-417, dt.18.07.03	Not applicable

**Details of Applications made for the Bio-diesel Project**

Industrial Entrepreneur Memorandum (IEM)- Ministry of Commerce and Industry	For commencing Bio Diesel Manufacturing unit	Application dated 25th July 2005 submitted to authorities	Acknowledgment dated 09.09.05 received from Ministry of Commerce & Industry, New Delhi, regarding filing of Industrial Entrepreneur Memorandum
---	--	---	--

**Details of Applications yet to be made for the Biodiesel Project**

Certificate of Explosives	For use and storage of Methanol	Application yet to be made	Time for getting sanction will be 30 days
Factory Licence for Biodiesel Plant	For Biodiesel plant at Kondapalli	Application yet to be made	
Power requirement for Biodiesel plant	125 KVA power connection required	Application yet to be made	
Water requirement for Biodiesel plant	Sufficient water is available at the present location and fresh connection not required	Our Company shall apply for these approvals for these approvals commissioning of the bio diesel plant.	



## SECTION VII: OTHER REGULATORY AND STATUTORY DISCLOSURES

### Authority for the Issue

Pursuant to Section 81(1A) of the Companies Act, 1956, the present issue of Equity Shares has been authorised vide Special Resolution passed at the Extra Ordinary General Meeting of our Company held on Augst 14,2008 and a resolution passed by the Board of Directors at its meeting held on July 19,2008

### Prohibition by SEBI

Our Company, its Directors/ Promoters and persons in control, its associates and companies/entities with which our Company's Directors/Promoters and any of our Company 's associates of group companies are associated as directors have not been prohibited from accessing/ operating in the capital markets under any direction or order passed by SEBI.

### Eligibility for the issue

- 1) Our Company fulfils the criteria of eligibility norms for public issue by unlisted company as specified in clause 2.2.1 of SEBI (Disclosure and Investor Protection) Guidelines, 2000 in the following manner.
  - a) Our Company has a pre issue net tangible assets of atleast Rs 300 lakhs in each of the preceding 5 full years ( of 12 months each) , of which not more than 50% is held in monetary assets.

Rs lakhs

Particulars	For the year ended March 31				
	2008	2007	2006	2005	2004
Fixed assets( Net)	129.09	111.72	690.33	108.94	113.41
Investments	3.00			1.00	1.00
Current assets, Loans and advances	2697.93	2375.63	1256.78	692.34	587.41
Less Current Liabilities and Provisions	789.49	1281.88	1238.94	561.71	593.81
Net Tangible assets	2040.53	1317.19	1398.50	350.51	222.42
Monetary Assets	14.25	1.27	0.49	1.81	3.54

Net tangible assets are defined as the sum of fixed assets (including capital work in progress and excluding revaluation reserves), investments, current assets (excluding deferred tax assets) less current liabilities (excluding deferred tax liabilities and long term liabilities), net of provision for diminution in value.

Monetary assets include cash on hand and bank and quoted investments including units in open ended mutual fund schemes.

- b) Our Company has a track record of distributable profits in terms of Section 205 of the Companies Act, for at least three (3) out of the immediately preceding five (5) years (As per restated statement of profit and loss Account)

Rs in Lakhs)

Particulars	For the year Ended March 31				
	2008	2007	2006	2005	2004
Profit after tax	122.76	93.62	75.68	18.39	8.41

- c) Our Company has a a net worth of atleast Rs 100 lakhs in each of the preceding 3 full years ( of 12 months each)

(Rs in Lakhs)

Particulars	For the year Ended March 31				
	2008	2007	2006	2005	2004
Share Capital	1051.82	1051.82	664.90	72.00	72.00
Share application money	0.00	-	-	161.60	30.00
Reserves and Surplus	278.51	155.75	46.42	11.17	6.01
Less Debit balance of profit & loss account	-	-	-	-	-
Less: Misc. Expenditure	(1.05)	(2.10)	(3.15)	(4.20)	-
Net worth	1329.28	1205.47	708.17	240.57	108.01



- (d) our company has not changed its name within the last one year
- (e) The aggregate of the proposed issue and all previous issues made in the same financial year in terms of size (i.e. offer through offer document + firm allotment + promoters' contribution through the offer document), does not exceed five (5) times its pre-issue net worth as per the audited balance sheet of the last financial year.
- |    |  |               |
|----|--|---------------|
| a) | Proposed issue through offer document  | 2464.00 lakhs |
| b) | All the previous issues made in the same financial year in terms of size (i.e.offer through offer documents + firm allotment promoter contribution through the offer document. | Nil           |
| c) | 5 times of the net worth results in our Company eligible to raise  | 6646.40 lakhs |

Based on the above data the Lead Managers have certified that the criteria of eligibility norms for public issue by unlisted companies as specified in the guidelines 2.2.1 of SEBI (DIP) Guidelines, 2000 are fulfilled.

In addition we ensure that the number of allottees getting equity shares is not less than one thousand in number

**SEBI DISCLAIMER CLAUSE:**

**AS REQUIRED, A COPY OF THE DRAFT PROSPECTUS HAS BEEN SUBMITTED TO SEBI. IT IS TO BE DISTINCTLY UNDERSTOOD THAT SUBMISSION OF THE DRAFT PROSPECTUS TO SEBI SHOULD NOT, IN ANY WAY, BE DEEMED OR CONSTRUED THAT THE SAME HAS BEEN CLEARED OR APPROVED BY SEBI. SEBI DOES NOT TAKE ANY RESPONSIBILITY EITHER FOR THE FINANCIAL SOUNDNESS OF ANY SCHEME OR THE PROJECT FOR WHICH THE ISSUE IS PROPOSED TO BE MADE OR FOR THE CORRECTNESS OF THE STATEMENTS MADE OR OPINIONS EXPRESSED IN THE DRAFT PROSPECTUS .THE BOOK RUNNING LEAD MANAGER ALLBANK FINANCE LIMITED HAS CERTIFIED THAT THE DISCLOSURES MADE IN THE DRAFT PROSPECTUS ARE GENERALLY ADEQUATE AND ARE IN CONFORMITY WITH SEBI (DISCLOSURE AND INVESTOR PROTECTION) GUIDELINES, 2000 AS FOR THE TIME BEING IN FORCE. THIS REQUIREMENT IS TO FACILITATE INVESTORS TO TAKE AN INFORMED DECISION FOR MAKING AN INVESTMENT IN THE PROPOSED ISSUE.**

**IT SHOULD ALSO BE CLEARLY UNDERSTOOD THAT WHILE THE COMPANY IS PRIMARILY RESPONSIBLE FOR THE CORRECTNESS, ADEQUACY AND DISCLOSURE OF ALL RELEVANT INFORMATION IN THE DRAFT PROSPECTUS, THE LEAD MANAGER IS EXPECTED TO EXERCISE DUE DILIGENCE TO ENSURE THAT THE COMPANY DISCHARGES ITS RESPONSIBILITY ADEQUATELY IN THIS BEHALF AND TOWARDS THIS PURPOSE, THE LEAD MANAGER ALLBANK FINANCE LIMITED, HAS FURNISHED TO SEBI, A DUE DILIGENCE CERTIFICATE DATED DECEMBER 29,2007 IN ACCORDANCE WITH THE SEBI (MERCHANT BANKERS) REGULATIONS, 1992 WHICH READS AS FOLLOWS:**

**“WE, THE UNDER NOTED LEAD MERCHANT BANKER TO THE ABOVE MENTIONED FORTHCOMING ISSUE STATE AS FOLLOWS:**

- 1. WE HAVE EXAMINED VARIOUS DOCUMENTS INCLUDING THOSE RELATING TO LITIGATION LIKE COMMERCIAL DISPUTES, PATENT DISPUTES, DISPUTES WITH COLLABORATORS ETC. AND OTHER MATERIALS MORE PARTICULARLY REFERRED TO IN THE ANNEXURE HERETO IN CONNECTION WITH THE FINALISATION OF THE DRAFT RED HERRING PROSPECTUS PERTAINING TO THE SAID ISSUE;**
- 2. ON THE BASIS OF SUCH EXAMINATION AND THE DISCUSSIONS WITH THE COMPANY, ITS DIRECTORS AND OTHER OFFICERS, OTHER AGENCIES, INDEPENDENT VERIFICATION OF THE STATEMENTS CONCERNING THE OBJECTS OF THE ISSUE,PROJECTED PROFITABILITY, PRICE JUSTIFICATION AND THE CONTENTS OF THE DOCUMENTS MENTIONED IN THE ANNEXURE AND OTHER PAPERS FURNISHED BY THE COMPANY,**





**WE CONFIRM THAT:**

- (a) THE DRAFT PROSPECTUS FORWARDED TO THE BOARD IS IN CONFORMITY WITH THE DOCUMENTS, MATERIALS AND PAPERS RELEVANT TO THE ISSUE;**
  - (b) ALL THE LEGAL REQUIREMENTS CONNECTED WITH THE SAID ISSUE AS ALSO THE GUIDELINES, INSTRUCTIONS, ETC. ISSUED BY THE BOARD, THE GOVERNMENT AND ANY OTHER COMPETENT AUTHORITY IN THIS BEHALF HAVE BEEN DULY COMPLIED WITH; AND**
  - (c) THE DISCLOSURES MADE IN THE DRAFT PROSPECTUS ARE TRUE, FAIR AND ADEQUATE TO ENABLE THE INVESTORS TO MAKE A WELL INFORMED DECISION AS TO THE INVESTMENT IN THE PROPOSED ISSUE (AND SUCH DISCLOSURES ARE IN ACCORDANCE WITH THE REQUIREMENTS OF THE COMPANIES ACT, 1956, THE SEBI (DISCLOSURE AND INVESTOR PROTECTION) GUIDELINES, 2000 AND OTHER APPLICABLE LEGAL REQUIREMENTS).**
- 3. WE CONFIRM THAT BESIDES OURSELVES, ALL THE INTERMEDIARIES NAMED IN THE DRAFT PROSPECTUS ARE REGISTERED WITH THE BOARD AND THAT TILL DATE SUCH REGISTRATION IS VALID.**
  - 4. WHEN UNDERWRITTEN, WE SHALL SATISFY OURSELVES ABOUT THE WORTH OF THE UNDERWRITERS TO FULFIL THEIR UNDERWRITING COMMITMENTS.**
  - 5. WE CERTIFY THAT WRITTEN CONSENT FROM PROMOTERS HAS BEEN OBTAINED FOR INCLUSION OF THEIR SECURITIES AS PART OF PROMOTERS' CONTRIBUTION SUBJECT TO LOCK-IN AND THE SECURITIES PROPOSED TO FORM PART OF PROMOTERS' CONTRIBUTION SUBJECT TO LOCK-IN, WILL NOT BE DISPOSED / SOLD / TRANSFERRED BY THE PROMOTERS DURING THE PERIOD STARTING FROM THE DATE OF FILING THE DRAFT RED HERRING PROSPECTUS WITH THE BOARD TILL THE DATE OF COMMENCEMENT OF LOCK-IN PERIOD AS STATED IN THE DRAFT PROSPECTUS.**
  - 6. WE CERTIFY THAT CLAUSE 4.6 OF THE SEBI (DISCLOSURE AND INVESTOR PROTECTION) GUIDELINES, 2000, WHICH RELATES TO SECURITIES INELIGIBLE FOR COMPUTATION OF PROMOTERS CONTRIBUTION, HAS BEEN DULY COMPLIED WITH AND APPROPRIATE DISCLOSURES AS TO COMPLIANCE WITH THE CLAUSE HAVE BEEN MADE IN THE DRAFT PROSPECTUS.**
  - 7. WE UNDERTAKE THAT CLAUSES 4.9.1, 4.9.2, 4.9.3 AND 4.9.4 OF THE SEBI (DISCLOSURE AND INVESTOR PROTECTION) GUIDELINES, 2000 SHALL BE COMPLIED WITH. WE CONFIRM THAT ARRANGEMENTS HAVE BEEN MADE TO ENSURE THAT ALL PROMOTER'S CONTRIBUTION AND SUBSCRIPTION FROM ALL FIRM ALLOTTEES WOULD BE RECEIVED ATLEAST ONE DAY BEFORE THE OPENING OF THE ISSUE. WE UNDERTAKE THAT AUDITORS CERTIFICATE TO THIS EFFECT SHALL BE DULY SUBMITTED TO THE BOARD. WE FURTHER CONFIRM THAT ARRANGEMENTS HAVE BEEN MADE TO ENSURE THAT PROMOTER'S CONTRIBUTION SHALL BE KEPT IN AN ESCROW ACCOUNT WITH A SCHEDULED COMMERCIAL BANK AND SHALL BE RELEASED TO THE COMPANY ALONG WITH THE PROCEEDS OF THE PUBLIC ISSUE NOT APPLICABLE**
  - 8. WHERE THE REQUIREMENT OF PROMOTERS' CONTRIBUTION IS NOT APPLICABLE TO THE ISSUER, WE CERTIFY THE REQUIREMENTS OF PROMOTERS' CONTRIBUTION UNDER CLAUSE 4.10 (SUB-CLAUSE (A), (B), OR (C), AS MAY BE APPLICABLE) ARE NOT APPLICABLE TO THE ISSUER - NOT APPLICABLE.**
  - 9. WE CERTIFY THAT THE PROPOSED ACTIVITIES OF THE ISSUER FOR WHICH THE FUNDS ARE BEING RAISED IN THE PRESENT ISSUE FALL WITHIN THE 'MAIN OBJECTS' LISTED IN THE OBJECT CLAUSE OF THE MEMORANDUM OF ASSOCIATION OR OTHER CHARTER OF THE ISSUER AND THAT THE ACTIVITIES WHICH HAVE BEEN CARRIED OUT UNTIL NOW ARE VALID IN TERMS OF THE OBJECT CLAUSE OF ITS MEMORANDUM OF ASSOCIATION.**
  - 10. WE CONFIRM THAT NECESSARY ARRANGEMENTS HAVE BEEN MADE TO ENSURE THAT THE MONEYS RECEIVED PURSUANT TO THE ISSUE ARE KEPT IN A SEPARATE BANK ACCOUNT AS PER THE PROVISIONS OF SECTION 73(3) OF THE COMPANIES ACT, 1956 AND THAT SUCH**



**MONEYS SHALL BE RELEASED BY THE SAID BANK ONLY AFTER PERMISSION IS OBTAINED FROM ALL THE STOCK EXCHANGES MENTIONED IN THE PROSPECTUS. WE FURTHER CONFIRM THAT THE AGREEMENT ENTERED INTO BETWEEN THE BANKERS TO THE ISSUE AND THE ISSUER SPECIFICALLY CONTAINS THIS CONDITION.**

- 11. WE CERTIFY THAT NO PAYMENT IN THE NATURE OF DISCOUNT, COMMISSION, ALLOWANCE OR OTHERWISE SHALL BE MADE BY THE ISSUER OR THE PROMOTERS, DIRECTLY OR INDIRECTLY, TO ANY PERSON WHO RECEIVES SECURITIES BY WAY OF FIRM ALLOTMENT IN THE ISSUE.**
- 12. WE CERTIFY THAT A DISCLOSURE HAS BEEN MADE IN THE DRAFT PROSPECTUS THAT THE INVESTORS SHALL BE GIVEN AN OPTION TO GET THE SHARES IN DEMAT OR PHYSICAL MODE- NOT APPLICABLE AS THE OFFER SIZE IS MORE THAN 10 CRORES, HENCE UNDER SECTION 68B OF THE COMPANIES ACT, 1956, THE EQUITY SHARES ARE TO BE ISSUED IN DEMAT ONLY.**
- 13. WE CERTIFY THAT THE FOLLOWING DISCLOSURES HAVE BEEN MADE IN THE DRAFT PROSPECTUS**
  - (a) AN UNDERTAKING FROM THE ISSUER THAT AT ANY GIVEN TIME THERE SHALL BE ONLY ONE DENOMINATION FOR THE SHARES OF THE COMPANY AND**
  - (b) AN UNDERTAKING FROM THE ISSUER THAT IT SHALL COMPLY WITH SUCH DISCLOSURE AND ACCOUNTING NORMS SPECIFIED BY THE BOARD FROM TIME TO TIME.”**

**ALL LEGAL REQUIREMENTS PERTAINING TO THE ISSUE WILL BE COMPLIED WITH AT THE TIME OF FILING OF THE PROSPECTUS WITH THE ROC IN TERMS OF SECTION 60B OF THE COMPANIES ACT, 1956. ALL LEGAL REQUIREMENTS PERTAINING TO THE ISSUE WILL BE COMPLIED WITH AT THE TIME OF REGISTRATION OF PROSPECTUS WITH THE ROC IN TERMS OF SECTIONS 60 AND 60B OF THE COMPANIES ACT.**

#### **General Disclaimer**

Investors may note that our Company and the Lead Manager accepts no responsibility for statements made otherwise than in this Prospectus or in the advertisements or any other material issued by or at the instance of our Company or the Lead Manager and that anyone placing reliance on any other source of information would be doing so at his/her own risk. All information shall be made available by the Lead Manager and the Issuer to the members at large and no selective or additional information would be available for a section of the members in any manner whatsoever.

The Lead Manager accepts no responsibility, save to the limited extent as provided in the Memorandum of Understanding entered into between the Lead Manager and our Company .

#### **Disclaimer in respect of Jurisdiction**

This Issue is being made in India to persons resident in India (including Indian nationals resident in India who are majors, Hindu Undivided Families, companies, corporate bodies and societies registered under the applicable laws in India and authorized to invest in shares, Indian mutual funds registered with SEBI, Indian financial institutions, commercial banks, regional rural banks, co-operative banks (subject to RBI permission), Trusts registered under the Societies Registration Act, 1860, or under any other trust law and who are authorized under their constitution to hold and invest in shares) and to NRIs, and FIIs as defined under the applicable Indian laws. This Prospectus does not, however, constitute an Issue to sell or an invitation to subscribe to shares issued hereby in any other jurisdiction to any person to whom it is unlawful to make an Issue or invitation in such jurisdiction. Any person into whose possession this Prospectus comes is required to inform himself about and to observe any such restrictions. Any dispute arising out of this Issue will be subject to the jurisdiction of appropriate court(s) in Hyderabad, Andhra Pradesh only. No action has been or will be taken to permit a public offering in any jurisdiction where action would be required for that purpose, except that this Prospectus has been submitted to the SEBI. Accordingly, the equity shares, represented thereby may not be offered or sold, directly or indirectly, and this Prospectus may not be distributed, in any jurisdiction, except in accordance with the legal requirements applicable in such jurisdiction. Neither the delivery of this Prospectus nor any sale hereunder shall, under any circumstances, create any implication



that there has been no change in the affairs of our Company since the date hereof or that the information contained herein is correct as of any time subsequent to this date.

Investors may please note that Central Government / RBI does not take any responsibility for the financial soundness or correctness of the statements disclosed in the Prospectus.

#### **Disclaimer clause of the Bombay Stock Exchange Ltd., Mumbai (BSE/ Designated Stock Exchange)**

As required, a copy of the Draft Prospectus has been submitted to BSE. The BSE has given vide its letter no.DCS/IPO/SI/IPO-IP/1823/2007 dated February 8, 2008 permission to our Company to use the BSE's name in this Prospectus as one of the stock exchanges on which our Company's securities are proposed to be listed. The BSE has scrutinized this Prospectus for its limited internal purpose of deciding on the matter of granting the aforesaid permission to our Company .

The BSE does not in any manner:

- i) Warrant, certify or endorse the correctness or completeness of any of the contents of this Prospectus; or
- ii) Warrant that our Company's securities will be listed or will continue to be listed on the exchange;
- iii) Take any responsibility for the financial or other soundness of our Company, its promoters, its management or any scheme or project of our Company.

and it should not for any reason be deemed or construed that this Prospectus has been cleared or approved by the BSE. Every person who desires to apply for or otherwise acquires any securities of our Company may do so pursuant to independent inquiry, investigation and analysis and shall not have any claim against the BSE whatsoever by reason of any loss which may be suffered by such person consequent to or in connection with such subscription/acquisition whether by reason of anything stated or omitted to be stated herein or for any other reason whatsoever.

#### **UNDERTAKING FROM PROMOTERS AND DIRECTORS**

Our Company accepts full responsibility for the accuracy for the information given in the Prospectus and confirms that to the best of their knowledge and belief, there are no other facts, their omission of which make any statement in the Prospectus misleading and they further confirm that they have made all reasonable inquiries to ascertain such facts. Our Company further declares that the Stock Exchanges to which an application for official quotation is proposed to be made do not take any responsibility for the financial soundness of this offer or for the price at which the Equity Shares are offered or for the correctness of the statement made or opinions expressed in this offer document.

The Promoters / Directors declare and confirm that no information / material likely to have a bearing on the decision of investors in respect of the shares offered in terms of the Draft Prospectus has been suppressed, withheld and/or incorporated in the manner that would amount to mis-statement, misrepresentation and in the event of its transpiring at any point of time till allotment / refund, as the case may be, that any information/ material has been suppressed / withheld and / or amounts to a mis-statement / mis-representation, the Promoters/Directors undertake to refund the entire application monies to all the subscribers within 7 days thereafter without prejudice to the provisions of Section 63 of the Companies Act.

The Issuer will update the Prospectus and keep the Public informed of any material changes in the document till the listing and trading.

#### **Filing**

1. Copy of the Prospectus has been filed with the SEBI at No. C-4A, G Block, Bandra Kurla Complex, Bandra (East), Mumbai- 400 051.
2. Copy of this Prospectus along with the documents required to be filed under Section 60 of the Act having attached thereto, has been delivered for registration to the Registrar of Companies, Andhra Pradesh at 2nd Floor, Kendriya Sadan, Sultan Bazar, Koti, Hyderabad.

#### **Listing**

The Equity Shares to be issued through this Prospectus are proposed to be listed on BSE. The company has received in-principle approval from BSE vide its letter no. DCS/IPO/SI/IPO-IP/1823/2007 dated February 8, 2008 for listing of the equity shares being issued in terms of this Prospectus.



If the permission to deal in for an official quotation of the Equity Shares is not granted by BSE, our Company shall forthwith repay, without interest all monies received from the applicants in pursuance of the prospectus. If such money is not repaid within 8 days after our Company becomes liable to repay it, then our Company and every director of our Company who is an officer in default shall, on and from the expiry of 8 days will be jointly and severally liable to pay money, at the interest rate of 15% per annum on application money as prescribed under Section 73 of the Companies Act, 1956.

Our Company together with the assistance of the Lead Managers shall ensure that all the steps for the completion of the necessary requirements for listing and commencement of trading at all the Stock Exchanges mentioned above are taken within 7 working days of finalisation and adoption of the Basis of Allotment for the Issue.

### **Impersonation**

**Attention of the applicants is specifically drawn to the provisions of sub-section (1) of Section 68 A of the Companies Act, which is reproduced below:**

**“Any person who:**

- a) Makes in a fictitious name, an application to a Company for acquiring or subscribing for, any shares therein, or**
- b) Otherwise induces a company to allot or register any transfer of shares, therein to him, or any other person in a fictitious name, shall be punishable with imprisonment for a term which may extend to five years.**

### **Consents**

Consents in writing of the Directors, Auditors, Lead Managers to the Issue, Bankers to our Company, Banker to the Issue, Company Secretary and Compliance Officer, Legal Advisors to the Issue, Registrars to the Issue to act in their respective capacities have been obtained and filed along with Copy of Prospectus with the Registrar of Companies, Andhra Pradesh as required under Section 60 of the Act, and none of them have withdrawn the said consents up to the time of delivery of a copy of this prospectus for Registration with the said Registrar of Companies Andhra Pradesh.

Mr. T.Nehru., Chartered Accountant, Statutory Auditor of our Company has also given their consent to the inclusion of his report as appearing hereinafter in the form and context in which it appears in this Prospectus and also of the tax-benefits accruing to our Company and to the members of our Company and such consent and report has not been withdrawn upto the time of delivery of this Prospectus for Registration with the Registrar of Companies, Andhra Pradesh.

### **Expert Opinion**

Except for the various tax benefits available to our Company and its members expressed by the auditors of our Company given in [page no.43](#) in the Prospectus, our Company has not obtained any other expert opinion.

### **Public Issue Expenses**

The expenses of the Issue payable by our Company inclusive of fees payable to the Lead Managers, Fees of Legal Advisors, Stamp Duty, Printing, Publication, Advertising and Distribution expenses, Bank charges, Fees payable to the Registrars to the Issue, Listing Fees, Brokerage and other Miscellaneous Expenses are estimated to be approximately Rs.159.85 lakhs and will be met out of the proceeds of the Issue.



Public Issue expenses are estimated as follows:

Particulars	(Rs. In Lakhs)
Brokerage	23.90
Lead Manager, registrar, legal Fee	30.55
Advertisement	20.00
Printing of Application, Prospectus & Brochures	31.50
Grading agency fee	2.25
Postage - Registered	8.00
Conferences	9.00
Connectivity Charges to BSE	1.00
Deposit to BSE	19.00
Travelling, conveyance and other expenses	14.65
<b>TOTAL</b>	<b>159.85</b>

#### **Fees Payable to the Lead Managers to the Issue**

The total fees payable to the Lead Managers will be as per the Memorandum of Understanding signed with the Lead Managers, a copy of which is available for inspection at the Registered Office of our Company.

The Lead Managers will be reimbursed for all relevant out-of-pocket expenses including such as cost of travel, stationery, postage & communication expenses.

#### **Fees Payable to the Registrar to the Issue**

The fees payable to the Registrar to the Issue will be as per the Memorandum of Understanding signed with our Company, a copy of which is available for inspection at the Registered Office of our Company.

The Registrar will be reimbursed for all relevant out-of-pocket expenses including such as cost of travel, stationery, postage, stamp duty & communication expenses. Adequate funds will be provided to the Registrar to the Issue to enable them to send refund orders or allotment advice by registered post.

#### **Underwriting Commission**

The issue is not proposed to be underwritten. Hence, no underwriting commission is payable

#### **Brokerage**

Brokerage will be paid by our Company at the rate upto 1.50 % on the issue price of Equity Shares offered to the Public on the basis of allotment made against applications bearing the stamp of the members of any recognized Stock Exchanges in India in the broker's column. Brokerage at the same rate will also be payable to the Bankers to the Issue in respect of allotments made against applications procured by them provided the relevant forms of applications bear their respective stamps in the Broker's column.

In case of tampering or over-stamping of Brokers/Agent's codes on the application form, our Company's decision to pay brokerage in this respect will be final and no further correspondence will be entertained in this matter.

#### **Previous Public or Rights Issues**

Our Company has not made any Public or Rights issues in the last 5 years.

#### **Previous Issues of shares otherwise than for cash.**

Our Company has issued 1, 19,999 Equity Shares by way of Bonus by capitalization of free reserves on 25th March 2004. Except for the above, no shares were issued for consideration other than cash.

#### **Commission and Brokerage on Previous Issue**

Our Company has not made any public or rights issue since inception and has not paid any commission or brokerage.

**Issues made by the Companies under the same management under Section 370(1B) of the Companies Act, 1956.**

There are no listed Companies under the same management with the meaning of Section 370(1B) of the Companies Act, 1956, which made any capital issue during the last three years.

**Outstanding debentures or redeemable preference shares**

Our Company has not issued any outstanding debentures or preference shares.

**Stock Market Data**

This being the initial public issue, the equity shares are not listed on any Stock Exchanges.

**Redressal of Investor Grievances**

Our Company has appointed the registrar to the issue, to handle the investor grievances in coordination with the Compliance Officer of our Company. All grievances relating to the present issue may be addressed to the Registrar with a copy to the Compliance Officer, giving full details such as name, address of the applicant, number of equity shares applied for, amount paid on application and bank and branch. Our Company would monitor the work of the registrar to ensure that the investor grievances are settled expeditiously and satisfactorily.

The Registrar to the issue, namely, Bigshare Services Pvt. Ltd. will handle investor grievances pertaining to the issue. A fortnightly status report of the complaints received and redressed by them would be forwarded to our Company. Our Company would also be co-coordinating with the Registrar to the issue in attending to the grievances to the investor.

Our Company assures that the Board of Directors in respect of the complaints, if any; to be received shall adhere to the following schedules:

Sl.No.	Nature of the Complaint	Time taken
1	Non-receipt of the refund warrants or share certificates	Within 7 days of receipt of complaint, subject to production of satisfactory evidence.
2	Change of address notification	Within 7 days of receipt of information.
3	Any other complaint in relation to public issue	Within 7 days of receipt of complaint with all relevant details.

**Compliance Officer**

Our Company has appointed Company Secretary & Compliance Officer who would directly deal with SEBI office with respect to implementation of various laws, rules, regulations and other directives issued by SEBI and matters related to investor complaints. The investors may contact the compliance officer in case of any pre-issue/post issue related problems. The Compliance Officer will be available at the following address:

Mr. Shaik Rahmatullah,  
Chemcel Bio-Tech Ltd.  
16-130/12, JRD Tata Industrial Estate,  
3rd Cross Road Extension,  
Kanuru, Vijayawada - 520007.  
Email: [complianceofficer@chemcelbiotechltd.com](mailto:complianceofficer@chemcelbiotechltd.com)  
Website: [www.chemcelbiotechltd.com](http://www.chemcelbiotechltd.com)

**Changes in Auditors during the last three years and reasons there for**

There has been no change in the Auditors of our Company during the last three years.

**Capitalisation of reserves or profits**

Our Company has issued 1,19,999 Equity Shares by way of Bonus by capitalization of free reserves on 25th March, 2004. Except for the above, no shares were issued for consideration other than cash.

**Revaluation of Assets**

Our Company has not revalued any of its assets since its incorporation.



## SECTION VIII. ISSUE RELATED INFORMATION

### 1. TERMS OF THE ISSUE

The Equity Shares being issued are subject to the provisions of the Companies Act, the Memorandum and Articles of Association, the terms of this Prospectus, Application Form, the Revision Form and other terms and conditions as may be incorporated in the allotment advices and other documents/certificates that may be executed in respect of the Issue. The Equity Shares shall also be subject to laws as applicable, guidelines, notifications and regulations relating to the issue of capital and listing and trading of securities issued from time to time by SEBI, the Government of India, the Stock Exchanges, the RBI, RoC and/or other authorities, as in force on the date of the Issue and to the extent applicable.

#### **i) Ranking of Equity Shares**

The Equity Shares being issued shall be subject to the provisions of the Memorandum and Articles of Association and shall rank *pari passu* in all respects with the existing Equity Shares including rights in respect of dividend. The allottees will be entitled to dividend or any other corporate benefits (including dividend), if any, declared by our Company after the date of Allotment of Equity Shares pursuant to the Issue. See the section titled "Main Provisions of the Articles of Association of our Company " beginning on page no. 189 of the Prospectus for a description of the Articles of Association.

#### **ii) Mode of Payment of Dividend**

The declaration and payment of dividends will be recommended by the Board of Directors and the shareholders, at their discretion, and will depend on a number of factors, including but not limited to the earnings, capital requirements and overall financial condition.

#### **iii) Face Value and Issue Price**

The Equity Shares with a face value of Rs.10/- each are being offered in terms of this Prospectus at a price of Rs. 16 per Equity Share. At any given point of time there shall be only one denomination for the Equity Shares of our Company , subjected to applicable laws. The issue price is 1.6 times the face value of the equity shares.

#### **iv) Compliance with SEBI DIP Guidelines**

Our Company shall comply with all disclosure and accounting norms as specified by SEBI from time to time. In this regard our Company has appointed Mr.Rahmatullah, Company secretary as the Compliance Officer of our Company .

#### **v) Rights of the Equity Shareholders**

Subject to applicable laws, rules, regulations and guidelines and the Articles of Association of our Company, the equity shareholders shall have the following rights:

- a Right to receive dividend, if declared.
- b Right to Receive Notices, attend general meetings and exercise voting rights, unless prohibited by law.
- c Right to vote on a poll either personally or by proxy.
- d Right to receive offer for rights shares and be allotted bonus shares, if announced;
- e Right to receive surplus on liquidation.
- f Right of free transferability; and
- g Such other rights, as may be available to a shareholder of a listed public ltd. company under the Companies Act, Listing Agreement with the Stock Exchanges and Articles of Association of our Company.

For further details on the main provisions of the Articles of Association relating to voting rights, dividend, forfeiture and lien, transfer and transmission and/or consolidation/splitting, please refer to section titled "Main Provisions of Articles of Association of our Company "on page no.189" of this Prospectus.

**vi) Market Lot And Trading Lot**

In terms of Section 68B of the Companies, 1956, the Equity Shares of our Company shall be allotted only in dematerialized form for all investors. In terms of existing SEBI DIP Guidelines, the trading in the Equity Shares of our Company shall be in dematerialized form, and hence, the marketable lot is one Equity Share. Allotment in the Issue will be only in electronic form in multiples of 1 Equity Share subject to a minimum Allotment of 350 Equity Shares. For details of allotment refer to chapter titled "Issue Procedure" under section titled "Issue Related Information" beginning on page no.163 of the Prospectus.

**vii) Nomination Facility to Investor**

In accordance with Section 109A of the Companies Act, 1956 the sole or first Applicant along with other joint Applicants, may nominate any one person in whom, in the event of death of sole Applicant or in case of joint Applicants, death of all the Applicants, as the Case may be, the Equity Shares allotted, if any, shall vest. A person, being a nominee, becoming entitled to the Equity Shares by reason of death of the original holder(s), shall in accordance with Section 109A of the Companies Act, 1956 be entitled to the same advantages to which he or she would be entitled if he or she were the registered holder of the Equity Share(s).

Where the nominee is a minor, the holder(s) may make a nomination to appoint, in the prescribed manner, any person to become entitled to Equity Share(s) in the event of his or her death during the minority. A nomination shall stand rescinded upon a sale/transfer/alienation of Equity Share(s) by the person nominating. A buyer will be entitled to make a fresh nomination in the manner prescribed. Fresh nomination can be made only on the prescribed Form available on request at the Registered Office of our Company or at the Registrar and Share Transfer Agent of our Company .

In accordance with Section 109B of the Act, any person who becomes a nominee by virtue of the provisions of Section 109A of the Act, shall upon the production of such evidence as may be required by the Board, elect either:

- a. To register himself or herself as the holder of the Equity Shares; or
- b. To make such transfer of the Equity Shares, as the deceased holder could have made.

Further, the Board may, at any time, give notice requiring any nominee to elect/ choose either to be registered himself or herself or to transfer the Equity Shares, and if the notice is not complied with within a period of ninety days, the Board may thereafter withhold payment of all dividends, bonuses or other moneys payable in respect of the Equity Shares, until the requirements of the notice have been complied with.

**Since the allotment of Equity Shares in the Issue will be made only in dematerialized mode, there is no need to make a separate nomination with our Company . Nominations registered with respective depository participant of the applicant would prevail. If the investor wants to change the nomination, they are requested to inform their respective depository participant.**

**As per the policy of RBI, Overseas Corporate Bodies cannot participate in the Issue. The Equity Shares have not been and will not be registered under the U.S. Securities Act 1933, as amended or any state securities laws in the United States and may not be offered or sold within the United States or to, or for the account or benefit of, "U.S. persons" (as defined in Regulation S of the U.S. Securities Act, 1933), except pursuant to an exemption from, or in a transaction not subject to, the registration requirements of the Securities Act. Accordingly, the Equity Shares will be offered and sold only (i) in the United States to "qualified institutional buyers", as defined in Rule 144A of the Securities Act, and (ii) outside the United States in compliances with Regulation S and the applicable laws of the jurisdiction where those offers and sales occur.**

**viii) Minimum Subscription**

"If our Company does not receive the minimum subscription of 90% of the issued amount on the date of closure of the issue, or if the subscription level falls below 90% after the closure of issue on account of cheques having being returned unpaid or withdrawal of applications, our Company shall forthwith refund the entire subscription amount received. If there is a delay beyond 8 days after our Company





becomes liable to pay the amount, our Company shall pay interest as per Section 73 of the Companies Act, 1956.

**ix) Withdrawal of the Issue**

Our Company in consultation with the Lead Manager(s) reserves the right not to proceed with the Issue, any time after the Issue opening date but before allotment without assigning any reason thereof.

**x) Period of Subscription**

The subscription list for public issue shall remain open for at least 3 working days and not more than 10 working days.

**xi) Arrangements for Disposal of Odd Lots**

Since, the Equity Shares will be traded in dematerialized form only; the marketable lot is one (1) Equity Share. Therefore, there is no possibility of any odd lots.

**xii) Restrictions, if any, on transfer/transmission of Equity Shares & on their consolidation and splitting**

For a detailed description in respect of restrictions, if any, on transfer and transmission of the Equity shares and on their consolidation/splitting, please refer to the sub-heading "Main Provisions of the Articles of Association of CHEMCEL BIO-TECH LIMITED "on page no.189" and in the chapter titled "Capital Structure" under section titled "Introduction" beginning on page no.19 of this Prospectus.





	Promoters contribution	Employees reservation portion #	Retail Investors	Non Retail Investors
				investors registered with SEBI, state industrial development corporations, insurance companies registered with Insurance Regulatory and Development Authority, provident funds (subject to applicable law) with minimum corpus of Rs. 250 million and pension funds with minimum corpus of Rs. 250 million in accordance with applicable law. National Investment Fund set up by Resolution F.NO. 2/3/2005 DD 11 DATED Nov.23,2005 in accordance with applicable law Resident Indian individuals, HUF (in the name of Karta), companies, corporate bodies, scientific institutions societies and trusts. Whose application amount does exceed Rs 100000/-

\* Under subscription, if any, in any of the categories shall be met through over subscription in any other category at the sole discretion of our company in consultation with the Lead Manager..

\*\* In case of the Application form is submitted in joint names, the investors should ensure that the demat account is also held in the same joint names and are in the same sequence in which they appear in the Application form .

**# With employee reservation portion the holding of the promoters shall not increase directly or indirectly. For Eligible Employee, see the section “Definitions and Abbreviations - Issue Related Terms - Employee or Eligible Employee” beginning on page iii of this Prospectus**



### 3. ISSUE PROCEDURE

#### Authority the Present Issue

Pursuant to Section 81(1A) of the Companies Act, 1956, the present issue of equity shares has been authorized vide a Special Resolution passed at the Extra Ordinary General Meeting of our Company held on August 14, 2008.

#### Principal Terms and Conditions of the issue

The Equity Shares, now being issued, are subject to the terms and conditions of this Prospectus, the Application Form, the Memorandum & Articles of Association of our Company, the guidelines for listing of securities issued by Government of India and guidelines issued by SEBI from time to time, the Depositories Act and the provisions of the Act. In addition, the Equity Shares shall also be subject to such other terms and conditions as may be incorporated in the letter of allotment, Share Certificates, as per guidelines, notifications and other regulations for the issue of capital and listing of securities laid down from time to time by the Government of India and/or other authorities and other documents that may be executed in respect of the Equity Shares. The issue size comprises of 1,54,00,000 equity shares of face value of Rs. 10/- each at a price of Rs. 16 for cash aggregating to Rs 2464 lakhs (the "issue"). The issue comprises of 16,00,000 equity shares of Rs.10/- each reserved for Promoters at a price of Rs16 (Promoters Contribution); 10,00,000 equity shares of Rs 10 each reserved for Eligible Employees on competitive basis at a price of Rs 16 (Employee reservation portion) subject to the valid applications being received at the issue price. The issue less the promoters contribution and employee reservation portion is referred to as the net issue.

Under-subscription, if any, in any category, would be allowed to be met with spill-over from any other category or combination of categories at the discretion of our Company in consultation with the Lead Managers and the Designated Stock Exchange.

#### 3. How To Apply

##### i) Availability of Prospectus and Application Forms

The Memorandum, Form 2A containing the salient features of the Prospectus together with Application Forms and copies of the Prospectus may be obtained from the Registered Office of our Company, Lead Manager(s) to the Issue, Registrar to the Issue, Brokers to the Public Issue and at the branches/collection centers of the Bankers to the Issue, as mentioned on the Application Form. NRIs/ FIIs can obtain the Application Form from the registered office of our Company.

##### ii) Who Can Apply:

- a) Indian Nationals, who are resident in India and are Adult Individuals and are not lunatic, or in the names of their minor children as natural/legal guardians, in single name or joint names (not more than three)
- b) Hindu Undivided Families (HUF) through the Karta of the Hindu Undivided Families or HUFs, in the individual name of the Karta. The Applicant should specify that the Application is being made in the name of the HUF in the Application Form as follows: "Name of Sole or First Applicant: XYZ Hindu Undivided Family applying through XYZ, where XYZ is the name of the Karta". Applications by HUFs would be considered at par with those from individuals;
- c) Companies, Bodies Corporate and Societies registered under the applicable laws in India and authorized to invest in the Equity Shares
- d) Indian Mutual Funds registered with SEBI, Indian Financial Institutions, Commercial Banks and Regional Rural Banks. Co-operative Banks may also apply subject to permission from Reserve Bank of India and SEBI regulations, if any):
- e) Scientific and/or Industrial Research Organizations which are authorized to invest in shares
- f) Indian Venture Capital Funds / Foreign Venture Capital Funds registered with SEBI subject to the applicable RBI Guidelines and Approvals, if any.
- g) State Industrial Development Corporations



- h) Insurance Companies registered with Insurance Regulatory and Development Authority
- i) Provident Funds with minimum corpus of Rs.2500 Lakhs and who are authorized under their constitution to hold and invest in equity shares
- j) Pension Funds with minimum corpus of Rs.2500 Lakhs and who are authorized under their constitution to hold and invest in equity shares
- k) Trusts or Societies registered under the Societies Registration Act, 1860 or any other applicable Trust Law and are authorized under its constitution to hold and invest in Equity Shares of a Company
- l) Foreign Institutional Investors (FIIs) on repatriation basis/ non-repatriation basis subject to applicable laws
- m) Permanent and Regular employees of our Company
- n) Non-Resident Indians (NRIs) on repatriation / non-repatriation basis subject to Applicable laws
- o) Multilateral and bilateral development financial institutions.
- p) Pursuant to the existing regulations, OCBs are not eligible to participate in the Issue.
- q) Permanent employees or Directors (whole-time Directors, part-time Directors or otherwise) of our Company, who are Indian Nationals and are based in India. The permanent employees should be on the payroll of our Company as of 25th August 2008 and the Directors should be directors on the date of the Prospectus.

**Note:** The LM shall not be entitled to subscribe to the Issue in any manner. However, associates and affiliates may subscribe for Equity Shares in the Issue, where the allotment is on a proportionate basis.

The information below is given for the benefit of the investors. Our Company and the LM are not liable for any amendment or modification or changes in applicable laws or regulations, which may occur after the date of the Prospectus. Investors are advised to ensure that Equity Shares applied for under any single applications form, from them does not exceed the investment limits or maximum number of Equity Shares that can be held by them under applicable law.

**iii) Applications not to be made by:**

- a) Minors
- b) Foreign Nationals (except NRIs)
- c) Partnership firms or their nominees
- d) Overseas Corporate Bodies (OCBs)

**iv) Applications by Hindu Undivided Families (HUF)**

Applications may be made by Hindu Undivided Families (HUF) through the Karta of the (HUF) and will be treated at par with individual applications.

**v) Minimum and Maximum Application Size**

Applications should be for minimum of 350 Equity Shares and in multiples of 350 Equity Shares thereafter. An applicant in the public category cannot make an application for that number of Equity Shares exceeding the number of Equity Shares offered to the public Under existing SEBI DIP Guidelines, a QIB applicant cannot withdraw its application after the Issue Closing Date.

**4. Option to Subscribe**

As on the date of this document, there are no pending options to subscribe to Equity Shares or convertible instruments pending conversion into Equity Shares of any kind. The investor shall have the option to subscribe to Equity Shares to be dealt with in a depository. In terms of Section 68B of the Companies Act, 1956, the Equity Shares in this Offer shall be allotted only in dematerialized form. The investor shall have the option to either receive the security certificates or to hold the securities in dematerialized form with a depository.



## 5. Filing of the Prospectus with the RoC

A copy of the Prospectus has been filed with the Registrar of Companies, Andhra Pradesh in terms of Section 56, Section 60 of the Companies Act.

## 6. Pre-Issue Advertisement

Our Company will issue a statutory advertisement after filing of the Prospectus with the RoC. This advertisement will contain the information that has to be set out in the statutory advertisement. Material updates, if any, between the date of filing the Prospectus with the RoC and the date of release of this statutory advertisement will be included in the statutory advertisement.

## 7. Option to Subscribe in the Issue

Equity Shares being offered through the Prospectus can be applied for in dematerialized form only. However the investor shall have the option to hold the Equity Shares in physical form or demat form. After the allotment in the proposed issue allottees may request their respective Depository Participant for rematerialisation of shares in physical shares.

## 8. Availability of Prospectus and Application Forms

The memorandum Form 2A containing the salient features of the Prospectus together with the application Forms and copies of the Prospectus may be obtained from the Registered Office of our Company, the Lead Manager to the Issue, the Registrar to the Issue, and at the collection centers of the Bankers to the Issue as mentioned on the application form.

NRIs/FIIs can obtain the Application Form from the Registered Office of our Company as well as from the Office of the Lead Manager.

### **Application by Mutual Funds/ Schedule Banks/Indian and Multilateral Development Financial Institutions**

#### ***As per the current regulations, the following restrictions are applicable for investments by mutual funds:***

No mutual fund scheme shall invest more than 10% of its net asset value in the Equity Shares or equity related instruments of any company provided that the limit of 10% shall not be applicable for investments in index funds or sector or industry specific funds. No mutual fund under all its schemes should own more than 10% of any company's paid-up share capital carrying voting rights. These limits would have to be adhered to by the mutual funds for investment in the Equity Shares. In case of a mutual fund, a separate Application can be made in respect of each scheme of the mutual fund registered with SEBI and such Applications in respect of more than one scheme of the mutual fund will not be treated as multiple Applications provided that the Applications clearly indicate the scheme concerned for which the Application has been made.

Schedule Banks and Indian and Multilateral Development Financial Institutions can apply in this public issue based upon their own investment limits and approvals.

### **Application by NRIs**

NRI applicants may please note that only such applications as are accompanied by payment in free foreign exchange shall be considered for allotment on repatriable basis. The NRIs who intend to make payment through Non-Resident Ordinary (NRO) accounts shall use the form meant for Resident Indians (White in colour) Application by NRIs for an amount of not more than Rs. 100,000/- would be considered under the Retail Portion for the purposes of allotment.

### **Application by FIIs**

#### ***As per the current regulations, the following restrictions are applicable for investments by FIIs:***

The allotment of Equity Shares to a single FII should not exceed 10% of the post-issue paid-up capital of our Company. In respect of an FII investing in Equity Shares of our Company on behalf of its sub-accounts, the investment on behalf of each sub-account shall not exceed 10% of our Company total issue capital or 5% of our Company total issued capital in case such sub-account is a foreign corporate or an individual.



Subject to compliance with all applicable Indian laws, rules, regulations, guidelines and approvals, in terms of Regulation 15A(1) of the SEBI (Foreign Institutional Investors) Regulations, 1995, as amended, an FII or its sub account may issue, deal or hold, off-shore derivatives instruments, such as Participatory Notes, Equity-Linked notes or any other similar instruments against underlying securities listed or proposed to be listed in any Stock Exchange in India only in favour of those entities which are regulated by any relevant regulatory authorities, in the countries of their incorporation or establishment, subject to compliance of "Know Your Client" requirements. An FII or sub account shall also ensure that no further downstream issue or transfer of any instrument referred to herein above is made to any other person other than a regulated entity.

#### **Application by SEBI Registered Venture Capital Funds And Foreign Venture Capital Investors**

##### ***As per the current regulations, the following restrictions are applicable for SEBI registered Venture Capital Funds and Foreign Venture Capital Investors:***

The SEBI (Venture Capital Funds) Regulations, 1996 and SEBI (Foreign Venture Capital Investor) Regulations, 2000 prescribe investment restrictions on venture capital funds and foreign venture capital investors registered with SEBI. Accordingly, the holding by any individual venture capital fund registered with SEBI, in one company should not exceed 25% of the corpus of the venture capital fund, a Foreign Venture Capital Investor can invest its entire funds committed for investments into India in one company. Further, Venture Capital Funds and Foreign Venture Capital Investors can invest only up to 33.33% of the investible funds by way of subscription to an initial public offer.

The above information is given for the benefit of the Applicants. Our Company and the LM are not liable for any amendments or modification or changes in applicable laws or regulations, which may happen after the date of the Prospectus. Applicants are advised to make their independent investigations and ensure that the number of Equity Shares applied for do not exceed the applicable limits under the laws or regulations, and our Company and the LM shall on no grounds whatsoever be liable for or responsible for any breach of applicable regulations by any investor or category of investors.

#### **Applications under Power of Attorney**

In case of Applications made pursuant to a power of attorney or by limited companies, corporate bodies, registered societies, a certified copy of the power of attorney or the relevant resolution or authority, as the case may be, along with a certified copy of the Memorandum of Association and Articles of Association and/or bye laws must be lodged along with the Application Form, Failing this, our Company reserves the right to accept or reject any Application in whole or in part, in either case, without assigning any reason therefor. In case of Applications made pursuant to a power of attorney by FIIs, a certified copy of the power of attorney or the relevant resolution or authority, as the case may be, along with a certified copy of their SEBI registration certificate must be lodged along with the Application Form. Failing this, our Company reserves the right to accept or reject any Application in whole or in part, in either case, without assigning any reason therefor. In case of Applications made by insurance companies registered with the Insurance Regulatory and Development Authority, a certified copy of certificate of registration issued by Insurance Regulatory and Development Authority must be lodged along with Application Form. Failing this, our Company reserves the right to accept or reject any Application in whole or in part, in either case, without assigning any reason therefor.

In case of Applications made by provident funds with minimum corpus of Rs.2500 Lakhs(subject to applicable law) and pension funds with minimum corpus of Rs. 2500 Lakhs, a certified copy of certificate from a chartered accountant certifying the corpus of the provident fund/ pension fund must be lodged along with the Application Form. Failing this, our Company reserves the right to accept or reject any Application in whole or in part, in either case without assigning any reason therefor.

In case of Applications made by Mutual Fund registered with SEBI, venture capital fund registered with SEBI and foreign venture capital investor registered with SEBI, a certified copy of their SEBI registration certificate must be submitted with the Application Form. Failing this, our Company reserves the right to accept or reject any Application in whole or in part, in either case, without assigning any reason.



Our Company in its absolute discretion, reserves the right to relax the above condition of simultaneous lodging of the power of attorney along with the Application Form, subject terms and conditions that our Company and the LM may deem fit.

## 9. General Instructions for Applicants

### Application Form

Applications must be made only on the prescribed Application Form and should be completed in BLOCK LETTERS in English, as per the instructions contained herein and in the Application Form, and are liable to be rejected if not so made. The prescribed application forms will have the following colors:

Category	Color
Indian public, NRIs applying on a non repatriation Basis	white
Non-residents including Eligible NRIs, FIIs, oreign Venture Capital Funds registered with SEBI, Multilateral and Bilateral Development Financial Institutions applying on a repatriation basis	Blue
Eligible employees	Pink

a) Application must be made only:

- i) For a minimum of 350 Equity Shares and in multiples of 350 thereafter.
- ii) In single name or joint names (not more than three);

Thumb impressions and signatures other than in English/Hindi or any other language specified in the 8th Schedule to the Constitution of India, must be attested by a Magistrate or a Notary Public or a Special Executive Magistrate under his/her official seal.

b) Bank Account Details of Applicant:

**IT IS MANDATORY FOR ALL THE APPLICANTS WILL GET THEIR EQUITY SHARES IN DEMATERIALIZED FORM. ALL APPLICANTS SHOULD MENTION THEIR DEPOSITORY PARTICIPANT'S NAME, DEPOSITORY PARTICIPANT IDENTIFICATION NUMBER AND BENEFICIARY ACCOUNT NUMBER IN THE APPLICATION FORM. INVESTORS MUST ENSURE THAT THE NAME GIVEN IN THE APPLICATION FORM IS EXACTLY THE SAME AS THE NAME IN WHICH THE DEPOSITORY ACCOUNT IS HELD. IN CASE THE APPLICATION FORM IS SUBMITTED IN JOINT NAMES, IT SHOULD BE ENSURED THAT THE DEPOSITORY ACCOUNT IS ALSO HELD IN THE SAME JOINT NAMES AND ARE IN THE SAME SEQUENCE IN WHICH THEY APPEAR IN THE APPLICATION FORM.**

Applicants should note that on the basis of name of the Applicants, Depository Participant's name, Depository Participant-Identification number and Beneficiary Account Number provided by them in the Application Form, the Registrar to the Issue will obtain from the Depository, demographic details of the Applicants such as address, bank account details for printing on refund orders or give credit through ECS and occupation (hereinafter referred to as "Demographic Details"). Hence, Applicants are advised to immediately update their bank account details including Magnetic Ink Character Recognition (MICR) Code (a nine-digit code appearing on a cheque leaf) as appearing on the records of the depository participant, and carefully fill in their Depository Account details in the Application Form. Please note that failure to do so could result in delays in credit of refunds to Applicants at the Applicants sole risk and neither the LM nor our Company nor the Refund Banker nor the Registrar shall have any responsibility and undertake any liability for the same.

These Demographic Details would be used for all correspondence with the Applicants including mailing of the refund orders/ECS credit for refunds/ Allocation Advice and printing of Company particulars on the refund order and the Demographic Details given by Applicants in the Application Form would not be used for these purposes by the Registrar. Hence, Applicants are advised to update their Demographic Details as provided to their Depository Participants and ensure that they are true and correct. Allocation Advice / refund orders/ECS refunds for credits/ refund advice would be mailed at the address of the Applicants as per the Demographic Details received from the Depositories.





Applicants may note that delivery of allocation advice/ refund orders/ intimation for ECS refunds of credits/ refund advice may get delayed if the same once sent to the address obtained from the Depositories are returned undelivered. In such an event, the address and other details given by the Applicant in Application Form would be used only to ensure dispatch of refund orders. Please note that any such delay shall be at the Applicants sole risk and neither our Company nor the Registrar nor the LM shall be liable to compensate the Applicant for any losses caused to the Applicant due to any such delay or liable to pay any such interest for such delay. In the case of refunds through electronic modes as detailed in page no. 181 to 183 of this Prospectus, Applicants may note that refund may get delayed if the bank particulars obtained from the Depositories are incorrect.

In case no corresponding record is available with the Depositories that matches three parameters, namely, names of the Applicants (including the order of names of joint holders), the Depository Participant's identity (DP ID) and the beneficiary's identity, then such Applications are liable to be rejected.

- c) By signing the Application Form, the Applicant would be deemed to have authorized the depositories to provide, upon request, to the Registrar to the Issue, the required Demographic Details as available on its records.
- d) Applicants should write their names and application serial number on the reverse of the instruments by which the payments are being made to avoid misuse of instruments submitted along with the applications for Equity Shares.
- e) An applicant in the public category cannot make an application for that number of securities exceeding the number of securities offered to the public. Payment should be made in cash or by cheque/Bank Draft drawn on any bank (including a Co-operative Bank), which is situated at and is a Member or Sub-member of the Banker's Clearing House located at the place where the application is submitted.
- f) A separate cheque or Bank draft should accompany each application form. Applicants should write the Share Application Number on the back of the Cheque /draft. Outstation Cheques will not be accepted and applications accompanied by such cheques drawn on outstation banks are liable for rejection. Money Orders/Postal Orders will not be accepted.
- g) All Cheques or Bank Drafts must be payable to any of the Bankers to the Issue with whom the application is lodged and marked "Name of the Bank A/c-M/s CHEMCEL BIO-TECH LIMITED Public Issue" and crossed "Account Payee Only" (e.g. \_\_\_\_\_ **Bank A/c CHEMCEL BIO-TECH LIMITED Public Issue**).
- h) All application Forms duly completed together with cash/ cheque/bank draft for the amount payable on application must be delivered before the closing of the subscription list to any of the Bankers to the Public Issue named herein or to any of their branches mentioned on the reverse of Application Form, and NOT to our Company or to the Lead Manager to the Public Issue or to the Registrars to the Public Issue.
- i) No receipt will be issued for the application money. However, Bankers to the Issue and/or their branches receiving the applications will acknowledge receipt by stamping and returning acknowledgment slip at the bottom of each application form.
- j) Every applicant should hold valid Permanent Account Number (PAN) allotted under the I.T. Act. and mention his/her Permanent Account Number in the application form while submitting application form. It is to be specifically noted that the applicants should not submit GIR No. instead of PAN as the application is liable to be rejected on this ground.**
- k) All Cheques/Bank Drafts accompanying the application form should contain the Application Form Number on the reverse of the instrument.
- l) The applicant should fill in the details of his/her bank account in the space provided in the application form failing which the application is liable to be rejected.
- m) Having regard to the provisions of Section 269 (SS) of the Income Tax Act, 1961, subscriptions against applications for securities should not be effected in cash and must be effected only by Account Payee cheques or Account Payee bank drafts, if the amount payable is Rs. 20,000/-or more. In case payment is effected in contravention of this provision, the application is liable to be rejected.



- n) Applicants residing at places where the designated branches of the Banker to the Issue are not located may submit/mail their applications at a their sole risk along with Demand Draft payable at Mumbai only payable to “**CHEMCEL BIO-TECH LIMITED-Public Issue**”
- o) Applications by NRIs on non-repatriation basis can be made using the Application Form meant for Resident Indians out of the funds held in Non-Resident Ordinary (NRO) Account.  
The relevant bank certificate must accompany such forms. Such applications will be treated on par with the applications made by the public.
- p) Our Company in its absolute discretion, reserves the right to permit the holder of Power of Attorney to request the Registrar that for the purpose of printing particulars on the refund order and mailing of Refund Orders/ECS refunds for credits/Allotment Advice, the demographic details given on the Application Form should be used (and not those obtained from the Depository of the Applicant). In such cases, the Registrar shall use Demographic details as given in the Application Form instead of those obtained from the Depositories.
- q) In case no corresponding record is available with the Depositories, which matches three parameters, namely, name(s) of the Applicant(s) (including the order of names of joint holders), the Depository Participant's identity (DP ID) and the beneficiary's identity, then such Applications are liable to be rejected.

**For further instructions please read Application Form carefully.**

#### **10. Terms of Payment**

The entire Issue price of Rs. 16/- per share is payable on application only. In case of allotment of lesser number of Equity Shares than the number applied, our Company shall refund the excess amount paid on application to the applicants.

#### **11. Submission of Completed Application Forms:**

All applications duly completed and accompanied by cash/ cheques/ bank drafts shall be submitted at any of the branches of the Bankers to the Issue (listed in the Application Form) before the closure of the Issue. Application(s) should not be sent to the office of our Company or the Lead Manager(s) to the Issue or the Registrars to the Issue.

Applicants residing at places where no collection centers have been opened may submit / mail their applications at their sole risk along with application money due there on by Bank Draft to the Registrar to the Issue **Bigshare Services Private Limited**, E-2, Ansa Industrial Estate, Sakivihar Road, Saki Naka, Andheri East, Mumbai 400072. super scribing the envelope “**CHEMCEL BIO-TECH LIMITED - Public Issue**” so as to reach the Registrar on or before the closure of the Subscription List. Such bank drafts should be payable at Mumbai only.

Our Company will not be responsible for postal delays and loss in transit. Our Company will not entertain any claims, damage or loss due to postal delays or loss in transit.

Our Company will not be responsible for postal delays and loss in transit. Our Company will not entertain any claims, damages or loss due to postal delays or loss in transit.

No separate receipts will be issued for the application money. However, the Bankers to the Issue or their approved collecting branches receiving the duly completed application form will acknowledge receipt of the application by stamping and returning to the applicant the acknowledgement slip at the bottom of each application form.

Applications shall be deemed to have been received by our Company only when submitted to the Bankers to the Issue at their designated branches or on receipt by the Registrar as detailed above and not otherwise.

#### **12. Payment Instructions**

- a) Payments should be made in cash or cheque or bank draft drawn on any Bank (including a Cooperative Bank), which is situated at and is a member or a sub-member of the Bankers' "Clearing



House”, located at the Centers (indicated in the Application Form) where the Application is accepted. However, if the amount payable on application is Rs. 20,000/- or more, in terms of section 269SS of the Income-Tax Act, 1961; such payment must be effected only by way of an account payee cheque or bank draft. Outstation cheques /bank drafts drawn on banks not participating in the clearing process will not be accepted and applications accompanied by such cheques or bank drafts are liable to be rejected. Cash/Stockinvest/Money Orders/Postal Orders will not be accepted. In case payment is effected in contravention of conditions mentioned herein, the application is liable to be rejected and application money will be refunded and no interest will be paid thereon. A separate cheque / bank draft must accompany each application form.

- b) Money orders, postal orders, outstation cheques or bank drafts, cheques / draft drawn on Banks not participating in the “clearing” will not be accepted and applications accompanied with such instruments may be rejected.
- c) All cheques / bank drafts accompanying the application should be crossed “A/c Payee Only” and must be made payable to the Bankers to the Issue where the application is lodged and marked as under :

**In case of resident QIB Investors : - Bank a/c: CHEMCEL BIO-TECH PUBLIC ISSUE - QIB - R”**

**In case of Non Resident QIB Investors :- Bank a/c CHEMCEL BIO-TECH PUBLIC ISSUE - QIB - NR”**

**In case of Resident Retail and Non Institutional Investors :- Bank a/c CHEMCEL BIO-TECH PUBLIC ISSUE -R”**

**In case of Non Resident Retail Non Institutional Investors :- Bank a/c CHEMCEL BIO-TECH PUBLIC ISSUE - NR”**

**In case of Eligible Employees:- Bank a/c CHEMCEL BIO-TECH PUBLIC ISSUE - Emp”**

- d) In case of Applications by NRIs applying on registration basis, the payments must be made through Indian Rupee draft purchased abroad or cheques or bank drafts, for the amount payable on application remitted through normal banking channels or out of funds held in Non-Resident External (NRE) Accounts or Foreign Currency Non-Resident (FCNR) Accounts, maintained with banks authorized to deal in foreign exchange in India, along with documentary evidence in support of the remittance. Payment will not be accepted out of Non-Resident Ordinary (NRO) Account of Non-Resident Applicant applying on a repatriation basis. Payment by drafts should be accompanied by bank certificate confirming that the draft has been issued by debiting to NRE Account or FCNR Account.
  - e) In case of Applications by FIIs, the payment should be made out of funds in Special Rupee Account along with documentary evidence in support of the remittance. Payment by drafts should be accompanied by bank certificate confirming that the draft has been issued by debiting to Special Rupee Account.
  - f) Investors will not have facility of applying through stock invest instruments as RBI has withdrawn the stock invest scheme vide notification no.DBOD.NO.FSC.BC.42/24.47.001/ 2003-04 dated 5/ 11/2003.
  - g) All cheques / bank drafts accompanying the application should be crossed “A/c Payee Only” and made payable to the Bankers to the Issue and marked:
13. Instructions For Applications By NRIs/FIIs (On Repatriable Basis):
- a) As per Notification No. FEMA 20 / 2000 - RB dated 3rd May 2000, as amended from time to time, under automatic route of Reserve Bank, our Company is not required to make an application for Issue of Equity Shares to NRIs/FIIs with repatriation benefits.
  - b) NRIs / FIIs / Indian Mutual Funds & Indian and Multilateral Development Financial Institutions can obtain the Application Form from either the Registered Office of our Company.



- c) In case of application by NRIs on repatriation basis, the payments must be made through Indian Rupees drafts purchased abroad or cheques or banks, for the amount payable on application remitted through approved banking channels or out of funds held in Non-Resident External (NRE) Accounts or Foreign Currency Non-Resident (FCNR) Accounts, maintained with banks authorized to deal in foreign exchange in India, along with documentary evidence in support of the remittance. Payment will not be accepted out of Non Resident Ordinary (NRO) Accounts of Non-Resident Subscribers applying on a repatriation basis. Payment by bank drafts should be accompanied by along with the Certificate from the Bank issuing the Draft confirming that the Draft has been issued by debit to NRE/FCNR account.
- d) However, the allotment / transfer of the Equity Shares to NRIs/FIIs shall be subject to RBI approval under prevailing RBI Guidelines or any other requisite statutory authority as may be necessary under the existing Exchange Control regulations. The sale proceeds of such investments in Equity Shares will be allowed to be repatriated along with the income thereon, subject to the permission of the RBI and subject to the Indian Tax Laws and regulations and any other applicable laws.
- e) In case of application by FIIs on repatriation basis, the payment should be made out of funds held in Special Non-Resident Rupee Account along with documentary evidence in support of the Remittance like certificates such as FIRC, bank certificate etc. from the authorized dealer. Payment by bank drafts should be accompanied by bank certificate confirming that the bank draft has been issued by debiting to Special Non-Resident Rupee Account.
- f) Duly filled Application Forms, by NRIs / FIIs, along with the cheques/bank drafts, will be accepted at designated branches of the Bankers to the Issue.
- g) Refunds/dividends and other distributions, if any, will be payable (net of Bank Charges/commissions) in Indian Rupees only. In case of applicants who remit their application money from funds held in NRE /FCNR accounts, such payments shall be credited to their respective NRE / FCNR accounts (details of which shall be furnished in the space provided for this purpose in the Application Form), under intimation to them. In case of applicants who remit their money through Indian Rupee Drafts from abroad, such payments in Indian Rupees will be converted into U.S. Dollars or any other freely convertible currency as maybe permitted by RBI at the exchange rate prevailing at the time of remittance and will be dispatched by registered post, or if the applicants so desire, will be credited to their NRE / FCNR accounts, details of which are to be furnished in the space provided for this purpose in the Application Form. Our Company will not be responsible for loss, if any, incurred by the applicant on account of conversion of Foreign Currency into Indian Rupees and vice versa.
- h) Applications in this category may please note that only such applications as are accompanied by payment in free foreign exchange shall be considered for allotment on repatriable basis. The NRIs who intend to make payment through Non-Resident Ordinary (NRO) accounts shall use the form meant for Resident Indians and shall not use the blue coloured forms meant for applications on repatriable basis.
- i) Our Company does not require approvals from FIPB or RBI for the transfer of Equity Shares in the Issue to eligible NRIs, FIIs, and foreign venture capital investors registered with SEBI and multilateral and bilateral development financial institutions. As per the RBI regulations, OCBs are not permitted to participate in the Issue.
- j) There is no reservation for Non Residents, NRIs, FIIs and foreign venture capital funds and all Non Residents, NRI, FII and foreign venture capital funds applicants will be treated on the same basis with other categories for the purpose of allotment.

*The Equity Shares have not been and will not be registered under the U.S. Securities Act 1933, as amended (the "Securities Act") or any state securities laws in the United States and may not be offered or sold within the United States or to, or for the account or benefit of, "U.S. persons" (as defined in the Regulation S of the Securities Act), except pursuant to an exemption from, or in a transaction not subject to, the registration requirements of the Securities Act. Accordingly, the Equity Shares may be offered and sold only (i) in the United States to "qualified institutional buyers", as defined in Rule 144A of the Securities Act, and (ii) outside the United States in compliance with Regulation S and the applicable laws of the jurisdiction where those offers and sale occur.*



14. Instructions For Applications By Indian Mutual Funds & Indian And Multilateral Development Financial Institutions:

- a) No mutual fund scheme shall invest more than 10% of its net asset value in the Equity Shares or equity related instruments of any company provided that the limit of 10% shall not be applicable for investments in index funds or sector or industry specific funds. Not mutual fund under all its schemes should own more than 10% of any company's paid-up share capital carrying voting rights. These limits would have to be adhered to by the mutual funds for investment in the Equity Shares.
- b) In case of a mutual fund, a separate application can be made in respect of each scheme of the Mutual Fund registered with SEBI and such applications in respect of more than one scheme of the mutual fund will not be treated as multiple applications provided that the Applications clearly indicate the scheme concerned for which the Applications had been made.
- c) The applications made by the Asset Management Company or Trustees / Custodians of a Mutual Fund shall clearly indicate the name of the concerned scheme for which application is being made.
- d) Schedule Banks and Indian Mutual Funds & Indian and Multilateral Development Financial Institutions should apply in this Public Issue based upon their own investment limits and approvals.
- e) Application Forms together with cheques or bank drafts drawn in Indian Rupees for the full amount payable at the rate of Indian Rs. 16 per Equity Share must be delivered before the close of subscription list to such branches of the Bankers to the Issue at places mentioned in the Application Form.
- f) A separate single cheque / bank draft must accompany each Application Form.

15. **Application under Employees Reservation portion :**

The applications must be for a minimum of 350 Equity Shares and in multiples of 350 Equity Shares thereafter. Investors under the Employee Reservation Portion can apply for a maximum of the size of the Issue. The allotment in the Employee Reservation Portion will be on a proportionate basis.

For the purpose of the Employee Reservation Portion, Eligible Employee means all or any of the following:

- (a) a permanent employee of our Company as of August 29, 2008 and based working and present in India as on the date of submission of the Application Form.
- (b) a director of our Company, whether a whole time director except any Promoters or members of the Promoter group, part time director or otherwise as of August 29, 2008 and based and present in India as on the date of submission of the Application Form.

Applications under Employee Reservation Portion by Eligible Employees shall be:

- Made only in the prescribed Application Form (i.e. pink colour form).
- Only Eligible Employees (as defined above) would be eligible to apply in this Issue under the Employee Reservation Portion.
- Eligible Employees, as defined above, should mention the Employee Number at the relevant place in the Application Form.
- The sole/ first Investor shall be the Eligible Employee as defined above.
- Applications by Eligible Employees will have to apply like any other Investor. Only those applications, which are received at or above the Issue Price, would be considered for allocation under this category.
- The application must be for a minimum of 350 Equity Shares and in multiples of 350 Equity Shares thereafter. The allotment in the Employee Reservation portion will be on a proportional basis.
- The maximum no. of shares an employee can apply for under Employee Reservation Portion cannot exceed the Issue size less the promoters' contribution.



- Application by Eligible Employees can also be made in the “Net Issue” portion and such Application shall not be treated as multiple applications.
- If the aggregate demand in this category is less than or equal to 10,00,000 Equity Shares at the Issue Price, full allocation shall be made to the Eligible Employees to the extent of their demand..
- If the aggregate demand in this category is greater than 10,00,000 Equity Shares at the Issue Price, the allocation shall be made on a proportionate basis. For the method of proportionate basis of allocation, see “Basis of Allotment” on page no.183.
- Under-subscription, if any, in the Employee Reservation Portion will be first added to the Net Issue, and the ratio amongst the investor categories will be at the discretion of our Company , and the LMs. In case of under-subscription in the Net Issue, spill over to the extent of under-subscription shall be permitted from the Employee Reservation Portion

**This is not an issue for sale within the United States of any equity shares or any other security of our Company . Securities of our Company , including any offering of its equity shares, may not be offered or sold in the United States in the absence of registration under U.S. securities laws or unless exempt from registration under such laws.**

#### **Reservation for Retail Individual Investor**

The above proportionate allotment of shares in this Issue, if oversubscribed shall be subject to the reservation for small individual applicants as described below -

- i) A minimum of 50% of the net offer of shares to the Public shall initially be made available for allotment to retail individual investors as the case may be that is those individual applicants (including HUFs) who have applied for Equity Shares of or for a value of not more than Rs. 1,00,000/-.
  - ii) The balance net Issue of shares to the public shall be made available for allotment to a) individual applicants other than retails individual investors who have applied for allotment of Equity Shares for a value of more than Rs. 1,00,000/-, and
- b) other investors, including Corporate Bodies/ Institutions irrespective of number of shares applied for.
  - iii) The unsubscribe portion of the net issue to any one of the categories specified in (i) or (ii) shall/may be made available for allocation to applicants in the other category, if so required

#### **16. Right to Reject Applications**

In case of all categories of Applicants our Company has a right to reject applications based on technical grounds. Consequent refunds shall be made by cheque or pay order or draft and will be sent to the Applicant’s address at the Applicant’s sole risk.

#### **Grounds for Technical Rejections**

Applicants are advised to note that Applications are liable to be rejected on among others on the following technical grounds:

- a) Applications not duly signed by the sole/joint Applicants;
- b) Amount paid doesn’t tally with the amount payable for the Equity Shares applied for;
- c) Bank account details (for refund) are not given;
- d) Age of First Applicant not given;
- e) In case of partnership firms, Equity Shares may be registered in the names of the individual partner and no firm as such shall be entitled to apply;
- f) Application by persons not competent to contract under the Indian Contract Act, 1872 including minors, insane persons;
- g) GIR number furnished instead of PAN. Refer “Issue Procedure-PAN or GIR No”
- h) Application for lower number of Equity Shares than specified for that category of investors;



- i) Applications for amounts greater than the maximum permissible amounts prescribed by the regulations;
- j) Applications by any persons outside India if not in compliance with applicable foreign and Indian laws;
- k) Application at a price less than the offer price;
- l) Application at a price higher than the stated price;
- m) Application for number of Equity Shares, which are not in multiples of 350.
- n) Category not ticked;
- o) Multiple applications as defined in Prospectus;
- p) In case of application under power of attorney or by limited companies, corporate, trust etc., relevant documents are not submitted;
- q) Application Form does not have Applicant's depository account details;
- r) Applications accompanied by Stockinvest/money order/postal order/cash;
- s) Signature of sole and/ or joint Applicant(s) missing;
- t) Application Forms are not delivered by the applicant within the time prescribed as per the Application Form, Issue Opening Date advertisement and the Prospectus and as per the instructions in the Prospectus and the Application Form;
- u) Applications by OCBs; or
- v) Applications by U.S. residents or U.S. persons other than "Qualified Institutional Buyers" as defined in Rule 144A of the U.S. Securities Act of 1933.
- w) In case no corresponding record is available with the Depositories that matches three parameters namely, names of the applicant (including the sequence of names of joint holders), the Depository Participant's Identity (DP ID) and the beneficiary's account number;

**For further instructions regarding application for the Equity Shares, investors are requested to read the Application Form carefully.**

#### **17. Acceptance of Applications**

LM and our Company reserve the right to reject any QIB Application without assigning any reason. In case of Non-Institutional applicants and Retail Individual applicants, Permanent Employees, LM and our Company have a right to reject applications based on technical grounds. Consequent refunds shall be made as per modes disclosed.

#### **18. General Information**

##### **(A) Joint Applications in case of Individuals**

Applications may be made in single or joint names (not more than three). In case of Joint Applications, refund, pay orders, dividend warrants etc. if any, will be drawn in favour of the first applicant and all communications will be addressed to the first applicant at her/his address as stated in the application form.

##### **(B) Multiple Applications**

An applicant should submit only one application form (and not more than one) for the total number of Equity Shares applied for. Two or more applications in single or joint names will be deemed to be multiple applications if the sole and/ or first applicant is one and the same.

In case of a mutual fund, a separate Application can be made in respect of each scheme of the mutual fund registered with SEBI and such Applications in respect of more than one scheme of the mutual fund will not be treated as multiple Applications provided that the Applications clearly indicate the scheme concerned for which the Application has been made.

NRIs/ FIIs applying on a repatriation basis shall not make an application in the public category and such applications made in both the categories i.e. reserved category and Public Category shall be treated as multiple applications.



Our Company reserves the right to accept or reject, in absolute discretion, any or all-multiple applications or all categories. Unless our Company specifically agrees in writing with or without such terms and conditions it deems fit, a separate cheque/draft must accompany each application form.

### **(C) Bank Account Details**

The applicant shall have to mention particulars relating to his saving bank / current account number and the name of the branch of the bank with whom such account is held in the respective spaces provided in the application form, to enable the registrars to print the said details in the refund orders after the names of the payee to prevent fraudulent encashment of refund order(s). Application forms without this information will be considered incomplete and will be liable to be rejected. The Applicant should note that on the basis of the name of the Applicant, Depository Participant's (DP) name, Depository Participants identification number and beneficiary account number provided by them in the Application Form, the Registrar to the Offer will obtain from the Applicant's DP A/c, the Applicant's bank account details. The investors are advised to ensure that bank account details are updated in their respective DP A/cs as these bank account details would be printed on the refund order(s), if any.

### **(D) PAN / GIR Number**

The applicant or in the case of applications made in joint names, each of the applicant, should mention his or her Permanent Account Number (PAN) allotted under the I.T. Act. In accordance with the SEBI Guidelines, the PAN would be the sole identification number for the participants transacting in the securities market, irrespective of the amount of transaction. Any Application Form without the PAN is liable to be rejected. It is to be specifically noted that applicants should not submit the GIR number instead of the PAN, as the application is liable to be rejected on this ground.

### **(F) Unique Identification Number-MAPIN**

Pursuant to circulars dated April 27, 2007 (No. MRD/DoP/Cir-05/2007) and June 25, 2007 (No. MRD/DoP/Cir-08/2007) issued by SEBI, the requirement of UIN under the SEBI (Central database of Market Participants) Regulations, 2005 has been discontinued and irrespective of the amount of transaction, PAN has been made the sole identification number for all participants in the securities market.

### **(G) Equity Share in Dematerialised Form with NSDL or CDSL**

As per the provisions of Section 68B of the Companies Act, the allotment of Equity Share of our Company can be held in a dematerialised form, (i.e. not in the form of physical certificates but be fungible and be represented by the Statement issued through electronic mode).

In this context, two tripartite agreements have been signed between our Company, the respective Depositories and the Registrar to the Issue:

- i. a Tripartite agreement dated March 11, 2008 between the NSDL, our Company and the Registrar to the Issue;
- ii. a Tripartite agreement dated March 4, 2008 between the CDSL, our Company and the Registrar to the Issue.

Successful allottees in this Issue will be compulsorily allotted Equity Shares in dematerialized form.

All investors can seek allotment only in dematerialised mode. However, an investor will have an option to hold the shares in physical form or demat form. After the allotment in the proposed Issue, allottees may request their respective DPs for rematerialization of shares if they wish to hold shares in physical form. Applications without relevant details of his or her depository account are liable to be rejected.

Application from any investor, opting for allotment in dematerialised form, without the details of his depository account is liable to be rejected.

An applicant applying for shares must have at least one beneficiary account with any of the Depository Participants (DPs) of NSDL or of CDSL, registered with SEBI, prior to making the application.

The Applicant must necessarily fill in the details (including the Beneficiary Account No. and Depository Participants Identification No.) in the Application Form.





Equity Shares allotted to successful applicants in the electronic account will be credited directly to the respective Beneficiary Accounts (with the Depository Participant)

Name(s) in the share Application Form should be identical to those appearing in the account details in the Depository. In case of joint holders, the names should necessarily be in the same sequence as they appear in the account details in the Depository.

The Registrar to this Issue will directly send non-transferable Allotment Letters/ Refund Orders to the Applicant.

Application will be liable to be rejected if incomplete or incorrect details are given under the heading 'Request for shares in electronic/dematerialized form' in the Application Form.

The applicant is responsible for the correctness of the Applicant's demographic details given in the Application Form vis-à-vis those with his/ her Depository Participant.

It may be noted that Equity Shares in electronic form can be traded only on the Stock Exchanges having electronic connectivity with NSDL and CDSL. All the Stock Exchanges where

Equity Shares of our Company are proposed to be listed is connected to NSDL and CDSL.

Trading in the Equity Shares of our Company would be in only dematerialized form for all investors.

### **Communications**

All future Communications in connection with Applications made in the Issue should be addressed to the Registrar to the Issue quoting the full name of the sole or First Applicant, Application Form number, Applicant's Depository Account details, number of Equity Shares applied for, date of Application Form, name and address of the Banker to the Issue where the Application was submitted and cheque or draft number and issuing bank thereof.

**Investors can contact the Compliance Officer or the Registrar to the Issue in case of any Pre-Issue related problems. In case of Post-Issue related problems such as non-receipt of letters of allotment / share certificates / credit of securities in depositories beneficiary account / refund orders, etc., Investors may contact Compliance Officer or Registrar to the Issue.**

***For further instructions regarding application for the Equity Shares, investors are requested to read the application form carefully.***

### **(H) Disposal of Applications and Application Money**

Our Company reserves, in own, absolute and uncontrolled discretion and without assigning any reason, the right to accept in whole or in part or reject any application. If an application is rejected in full, the entire application money received will be refunded to the applicant. If the application is rejected in part, excess of the application money received will be refunded to the applicant within 30 (thirty) days from the date of closure of the Issue. No interest will be payable on the application money so refunded.

Our Company shall make refunds in case of over subscription using the following modes:

- a In case of applicants residing in any of the 15 centers specified by the Board - by crediting of refunds to the bank accounts of applicants through electronic transfer of funds by using ECS (Electronic Clearing Service), Direct Credit, RTGS (Real Time Gross Settlement) or NEFT (National Electronic Funds Transfer), as is for the time being permitted by the Reserve Bank of India;
- b In case of other applicants - by dispatch of refund orders by registered post, where the value up to Rs 1500/- by "Under Certificate of Posting and shall dispatch refund orders above Rs.1, 500/-, if any, by registered post or speed post, except for Applicants who have opted to receive refunds through the ECS facility and
- c Applicants to whom refunds are made through Electronic transfer of funds will be sent a letter through ordinary post intimating them about the mode of credit of refund within 30 days of closure of Issue.
- d Our Company shall ensure dispatch of refund orders, if any, by "Under Certificate of Posting" or registered post or speed post or ECS, as applicable, only at the sole or First Applicant's sole risk within



30 days of the Issue Closing Date, and adequate funds for making refunds to unsuccessful applicants as per the mod(s) disclosed shall be made available to the Registrar to the Issue by the Issuer.

- e In case of any category of applicants specified by the Board - crediting of refunds to the applicants in any other electronic manner permissible under the banking laws for the time being in force which is permitted by the Board from time to time.”
- f Our Company shall ensure dispatch of allotment advice, refund orders and give benefit to the beneficiary account with Depository Participants and submit the documents pertaining to the allotment to the Stock Exchanges within 2 (two) working days of date of Allotment.
- g Our Company shall use best efforts to ensure that all steps for completion of the necessary formalities for listing and commencement of trading at all the Stock Exchanges where the Equity Shares are proposed to be listed, are taken within 7(seven) working days of the finalisation of the basis of allotment.

In accordance with the Companies Act, the requirements of the Stock Exchanges and SEBI DIP Guidelines, our Company further undertakes that:

- i. Allotment shall be made only in dematerialized form within 30 (thirty) days of the Issue Closing Date;
- ii. Dispatch refund orders within 30 (thirty) days of the Issue Closing Date would be ensured; and
- iii. Our Company shall pay interest at 15% (fifteen) per annum (for any delay beyond the 30 (thirty) days time period as mentioned above), if allotment is not made and refund orders are not dispatched and/or demat credits are not made to investors within the 30(thirty) days time prescribed above as per the Guidelines issued by the Government of India, Ministry of Finance pursuant to their letter No. F/8/S/79 dated July 31,1983 as amended by their letter No.F/14/SE/85 dated September 27,1985, addressed to the Stock Exchanges, and as further modified by SEBI's Clarification XXI dated October 27,1997, with respect to the SEBI DIP Guidelines.

Such refund orders will be payable at par at all the collection centers.

The subscription received in respect of Public Issue will be kept in a separate bank account and our Company shall not have access to such funds unless approval for dealing from all the Stock Exchanges, where listing has been proposed, is received.

Our Company has undertaken to make adequate funds available to the Registrar to the Issue for making refunds to unsuccessful applicants as per the mode(s) disclosed.

#### **(I) IMPERSONATION**

**Attention of the applicants is specifically drawn to the provisions of sub-section (1) of Section 68A of the Companies Act, 1956, which is reproduced below:**

“Any person who:

- a) **Makes in a fictitious name, an application to a Company for acquiring or subscribing for, any shares therein, or**
- b) **Otherwise induces a Company to allot, or register any transfer of shares therein to him, or any other person in a fictitious name, shall be punishable with imprisonment for a term which may extend to five years.”**

#### **(J) Interest in case of Delay in Dispatch of Allotment Letters/Refund Orders As per Section73 (2A) of the Companies ACT 1956.**

Our Company agrees that as far as possible allotment of securities offered to the public shall be made within 30 days of the closure of Public Issue. Our Company further agrees that it shall pay interest @15% per annum if the allotment letters/ refund orders have not been dispatched to the applicants or if, in, a case where the refund or portion thereof is made in electronic manner, the refund instructions have not been given to the clearing system in the disclosed manner) within 30 days from the date of the closure of the Issue.

**(K) Basis of Allotment**

In the event of the Present Issue of Equity Shares being oversubscribed, allotment shall be made on a proportionate basis and the basis of allotment will be finalized in accordance with the SEBI DIP Guidelines and in consultation with BSE (Designated Stock Exchange) The Executive Director/Managing Director of BSE along with the Lead Manager and the Registrar to the Issue shall be responsible to ensure that the basis of allotment is finalized in a fair and proper manner in accordance with the relevant guidelines:

**Procedure and Time Schedule for Allotment of Equity Shares and Demat Credit of Equity Shares****ISSUE OPENS ON: September 09, 2008****ISSUE CLOSES ON: September 12, 2008**

Our Company, in consultation with the LM, will determine the Issue Price, and the basis of allotment based on the Applications received and subject to the confirmation by the BSE. SEBI DIP Guidelines require our Company to complete the allotment to successful Applicants within 30 days of closure of the Issue. The Equity Shares will then be credited and allotted to the investors' demat accounts maintained with the relevant depository participant. Upon approval by the Stock Exchange, the Equity Shares will be listed and trading will commence. This typically takes three trading days from the date of crediting the investor's demat account, subject to final approval by the Stock Exchanges.

**Method of Proportionate Basis of Allotment**

Allotment shall be on proportionate basis within the specified categories, rounded off to the nearest integer subject to a minimum allotment being equal to the minimum application size i.e. 350 Equity Shares.

**Fresh Issue to Public**

In the event of Issue being over-subscribed, the allotment will be on a proportionate basis subject to minimum allotment being equal to the minimum application size, i.e. 350 Equity Shares as explained below:

1. A minimum 50% of the Fresh Issue to the Indian Public will be made available for allotment in favour of those Retail Individual Investors/applicants that is those individual applicants (including HUF's) who have applied for Equity Shares of or for a value of not more than Rs.1,00,000/-. This percentage may be increased in consultation with the Designated Stock Exchange depending on the extent of response to the Issue from investors in this category. In case allotments are made to a lesser extent than 50% because of lower subscription in the above category, the balance Equity Shares would be added to the higher category/ other categories and allotment made on a proportionate basis as per relevant SEBI DIP Guidelines. The Executive Director/Managing Director of the Designated Stock Exchange along with the Lead Manager and the Registrar to the Issue shall be responsible to ensure that the basis of allotment is finalized in a fair and proper manner in accordance with the SEBI DIP Guidelines.
2. The balance of the Fresh Issue to Indian Public shall be made available to investors including Corporate Bodies/Institutions and individual Applicants who have applied for allotment of Equity Shares for a value of more than Rs.1,00,000/-, irrespective of number of Equity Shares applied for.
3. The Unsubscribed portion of the Fresh Issue to any of the categories specified in (1) or (2) shall be made available for allotment to Applicants in the other category, if so required. 4. Applicants will be categorized according to the number of Equity Shares applied for.
5. The total number of shares to be allotted to each category as a whole shall be arrived at on a proportionate basis i.e., the total number of shares applied for in that category (number of applicants in the category multiplied by the number of shares applied for) multiplied by the inverse of the over subscription ratio.
6. Number of the shares to be allotted to the successful allottees shall be arrived at on a proportionate basis i.e., total number of shares applied for by each applicant in that category multiplied by the inverse of the over subscription ratio.
7. All the Application Forms where the proportionate allotment works out to less than 350 shares per Applicant, the allotment shall be made as follows:



- a Each successful Applicant shall be allotted a minimum of 350 shares; and
  - b The successful Applicants out of the total applicants for that category shall be determined by draw of lots in such a manner that the total number of shares allotted in that category is equal to the number of shares worked out as per (6) above.
8. If the proportionate allotment to an Applicant works out to a number that is more than 350 Equity Shares but is a fraction, the fraction equal to or higher than 0.50 shall be rounded off to the next integer and if that fraction is lower than 0.50, the fraction shall be ignored.
  9. All the Applicants in such categories shall be allotted shares arrived at after such rounding off.
  10. If the shares allocated on a proportionate basis to any category are more than the shares allotted to the Applicants in that category, the balance available shares for allotment shall be first adjusted against any other category, where the allocated shares are not sufficient for proportionate allotment to the successful Applicants in that category.
  11. The balance of Equity Shares, if any, remaining after such adjustment shall be added to that category comprising applicants applying for minimum number of shares.
  12. The process of rounding off to the nearest integer subject to a minimum allotment being equal to 350 Equity Shares, which is the minimum application size in this Issue, may result in the actual allotment being higher than the shares offered. However, it shall not exceed 10% of the net offer to public.

**Retail individual investor means an investor who applies for shares of value of not more than Rs. 1,00,000/-**

Investors may note that in case of over-subscription allotment shall be on proportionate basis and will be finalized in consultation with BSE. The drawl of lots (where required) to finalize the basis of allotment shall be done in the presence of a public representative on the governing board of the

BSE. The Executive Director / Managing Director of the Designated Stock Exchange in addition to Lead Merchant Bankers and Registrar to the Issue shall be responsible to ensure that the basis of allotment is finalized in a fair and proper manner in accordance with the SEBI DIP Guidelines.

#### **(L) Letters of Allotment or Refund Orders**

Our Company shall give credit to the Beneficiary Account with Depository Participants within Two (2) working days of finalisation of the basis of allotment of Equity Shares. Our Company shall ensure that all steps for the completion of the necessary formalities for listing and commencement of trading at BSE are taken within 7 working days of finalisation of the Basis of Allotment for the Issue.

In accordance with the Companies Act, the requirements of the Stock Exchanges and SEBI DIP Guidelines, we undertake that:

- a Allotment of Equity Shares, only in dematerialized form, shall be made within 30 days from the Issue Closing Date;
- b Dispatch of refund orders shall be done within 30 days from the Issue Closing Date; and
- c Our Company shall pay interest at 15% per annum (for any delay beyond the 30 days time period as mentioned above), if refund orders are not dispatched and/or demat credits are not made to investors within the 30 day time period prescribed above
- d In case of applicants residing in any of the centers specified by the Board - - refunds shall be credited through electronic transfer of funds by using ECS (Electronic Clearing System), Direct Credit, RTGS (Real Time Gross Settlement) or NEFT (National Electronic Funds Transfer), as is for the time being permitted by the Reserve Bank of India;
- e In case of other applicants - where the value of refund order is Rs. 1500/- or more, refund orders will be dispatched to the applicants by registered post;
- f In case of any category of applicants specified by the Board - crediting of refunds to the applicants in any other electronic manner permissible under the banking laws for the time being in force which is permitted by the Board from time to time.



Refunds other than (a) above, will be made by cheques or pay-orders drawn on the bank(s) appointed by our Company, as refund banker(s). Such instruments will be payable at par at the places where applications are accepted. Bank charges, if any, for encashing such cheques or pay orders will be payable by the applicant.

Our Company will provide adequate funds required for dispatch of refund orders or allotment advice to the Registrar to the Issue.

**(M) Mode of making refunds**

Applicants should note that on the basis of name of the Applicants, Depository Participant's name, Depository Participant-Identification number and Beneficiary Account Number provided by them in the Application Form, the Registrar to the Issue will obtain from the Depository the Applicants bank account details including nine digit MICR code. Hence, Applicants are advised to immediately update their bank account details as appearing on the records of the depository participant. Please note that failure to do so could result in delays in credit of refunds to Applicants at the Applicants sole risk and neither the LM nor our Company shall have any responsibility and undertake any liability for the same.

The payment of refund, if any, would be done through various modes in the following order of preference:

1. **a. ECS:** Payment of refund would be done through ECS for applicants having an account at any of the following Sixty eight centers -

1. Ahmedabad	2. Nashik	3. Sholapur	4. Gorakhpur
5. Bangalore	6. Panaji	7. Ranchi	8. Jammu
9. Bhubaneshwar	10. Surat	11. Tirupati (non- MICR)	12. Indore
13. Kolkata	14. Trichy	15. Dhanbad(non-MICR)	16. Pune
17. Chandigarh	18. Trichur	19. Nellore (non-MICR)	20. Salem
21. Chennai	22. Jodhpur	23. Kakinada(non-MICR)	24. Jamshedpur
25. Guwahati	26. Gwalior	27. Agra	28. Visakhapatnam
29. Hyderabad	30. Jabalpur	31. Allahabad	32. Mangalore
33. Jaipur	34. Raipur	35. Jalandhar	36. Coimbatore
37. Kanpur	38. Calicut	39. Lucknow	40. Rajkot
41. Mumbai	42. Siliguri (non-MICR)	43. Ludhiana	44. Kochi/Ernakulam
45. Nagpur	46. Pondicherry	47. Varanasi	48. Bhopal
49. New Delhi	50. Hubli	51. Kolhapur	52. Madurai
53. Patna	54. Shimla (non-MICR)	55. Aurangabad	56. Amritsar
57. Thiruvananthapuram	58. Tirupur	59. Mysore	60. Haldia (non- MICR)
61. Baroda	62. Burdwan (non-MICR)	63. Erode	64. Vijaywada
65. Dehradun	66. Durgapur (non-MICR)	67. Udaipur	68. Bhilwara

This would be subject to availability of complete Bank Account Details including MICR code from the depository. The payment of refund through ECS is mandatory for applicants having bank account at any of the 68 centers named herein above, except where applicant is otherwise disclosed as eligible to get refunds through direct credit or RTGS or NEFT.

- b. **Direct Credit:** Investors having their bank account with the Refund Bank, \_\_\_\_\_ shall be eligible to receive funds, if any, through Direct Credit. The refund amount, if any, would be credited directly to their bank account with the Refund Banker.
- c. **RTGS:** Applicants having a bank account at any of the 68centers detailed above, and whose Application amount exceeds Rs. 10 Lakhs, shall be eligible to exercise the option to receive refunds, if any, through



RTGS. All applicants eligible to exercise this option shall mandatorily provide the IFSC code in the Application Form. In the event of failure to provide IFSC code in the Application Form, the refund shall be made through ECS or Direct Credit, if eligibility is disclosed;

- d. **NEFT** (National Electronic Fund Transfer): Payment of refund shall be undertaken through NEFT wherever the applicants' bank has been assigned the Indian Financial System Code (IFSC), which can be linked to a Magnetic Ink Character Recognition (MICR), if any, available to that particular bank branch. IFSC CODE will be obtained from the website of RBI as on a date immediately prior to the date of payment of refund, duly mapped with MICR numbers.

Wherever the applicants have registered their nine digit MICR number and their bank account number while opening and operating the demat account, the same will be duly mapped with the IFSC Code of that particular bank branch and the payment of refund will be made to the applicants through this method. The process flow in respect of refunds by way of NEFT is at an evolving stage and hence use of NEFT is subject to operational feasibility, cost and process efficiency.

- e. For all the other applicants, including applicants who have not updated their bank particulars along with the nine digit MICR Code, the refund orders would be dispatched "Under Certificate of Posting" for refund orders of value up to Rs. 1500/- and through Speed Post/ Registered Post for refund orders of Rs. 1500/- and above.
- f. Please note that only applicants having a bank account at any of the 68 centers where clearing houses for ECS are managed by RBI are eligible to receive refunds through the modes detailed in (a), (b) and (c) herein above.

**(N) Interest in Case of Delay in Dispatch of Allotment Letters / Refund Orders in case of Public Issue**

Our Company agrees that as far as possible allotment of Equity Shares offered to the public shall be made within 30 days of the closure of Public Issue. Our Company further agrees that it shall pay interest @15% per annum if the allotment letters/ refund orders have not been dispatched to the applicants or if, in a case where the refund or portion thereof is made in electronic manner, the refund instructions have not been given to the clearing system in the disclosed manner within 30 days from the date of the closure of the Issue.

**(O) Scope of activities of the Registrar to the Issue**

The Registrar to the Issue shall also be the share transfer agent and would also be responsible for all the post issue activities pertaining to this issue. All future communications in connection with Application made in this Issue should be addressed to the Registrar to the Issue quoting the full name of the sole or First Applicant, Application Form number, number of Equity Shares applied for, date, bank and branch where the application was submitted and cheque/draft number and issuing bank thereof. The trading of equity shares would be dematerialized form only for all the investors.

**(P) Undertaking by our Company :**

Our Company undertakes:

- That the complaints received in respect of the Issue shall be attended to by our Company expeditiously and satisfactorily.
- That all steps for completion of the necessary formalities for listing and commencement of trading at stock exchange where the Equity Shares are proposed to be listed are taken within seven working days of finalization of basis of allotment.
- That the funds required for making refunds to unsuccessful applicants as per the mode(s) disclosed under the heading "Modes of making refunds" beginning on page no. 211 of the Prospectus shall be made available to the Registrar to the issue by the issuer.
- That where refunds are made through electronic transfer of funds, a suitable communication shall be sent to the applicant within 30 days of the final transfer date, giving details of the bank where refunds shall be credited along with amount and expected date of electronic credit of refund.



- That the refund orders or allotment advice to the successful Applicants shall be dispatched within specified time;
- That the certificates of the Equity Shares / refund orders to the non-resident Indians shall be dispatched within specified time.
- That no further Issue of Equity Shares shall be made till the Equity Shares issued through this Prospectus are listed or till the application moneys are refunded on account of nonlisting, under subscription, etc.
- That the allotment advice/refund order to the NRIs/FIIs shall be dispatched within the specified time. Our Company will provide adequate funds required for dispatch of refund orders / electronic transfer of funds for refunds or allotment advice to the Registrar to the Issue.

**(Q) Utilization of Issue Proceeds**

The Board of Directors of our Company certifies that:

- a All monies received out of this Issue of Equity Shares to public shall be credited/transferred to a separate bank account other than the bank account referred to in sub-section (3) of section 73 of the Companies Act;
- b Details of all monies utilized out of the Issue referred to in sub-item (a) shall be disclosed under an appropriate separate head in the balance-sheet of our Company indicating the purpose for which such monies had been utilized; and

Details of all unutilized monies out of the Issue of Equity Shares, if any, referred to in sub item (a) shall be disclosed under an appropriate separate head in the balance-sheet of our Company indicating the form in which such unutilized monies have been invested.

The Board of Directors of our Company further certifies that:

- i) Pending utilization of net proceeds of the Issue of Equity Shares as specified under the section "Objects of the Issue", the net proceeds will be invested by our Company in high quality interest bearing liquid instruments including but not limited to deposits with banks for the necessary duration.
- ii) Our Company shall not have any recourse to the Issue proceeds until the approval for listing and trading of Equity Shares is received from all the Stock Exchanges where listing is sought is received.

**13. Rectification of Register of Members**

Our Company, under Section 111A of the Companies Act will have the right to rectify the register of members to comply with the Companies Act.

**14. Restrictions on Foreign Ownerships of Indian Securities, if any**

Foreign investment in Indian securities is regulated through the industrial policy of the Government of India, notified through press notes and press releases issued from time to time and the FEMA and circulars and notifications issued there under. While the Policy of Government prescribes the limits and the conditions subject to which foreign investment can be made in different sectors of the Indian economy, FEMA regulates the precise manner in which such investment may be made. Under the Industrial Policy of the Government of India, unless specifically restricted, foreign investment is freely permitted in all sectors of Indian economy up to any extent and without any prior approvals, but the foreign investor is required to follow certain prescribed procedures and reporting requirements for making such investment. As per current foreign investment policies, foreign direct investment in the industries in which our Company operates is allowed upto 100% under the automatic route. By way of Circular No.53 dated December 17, 2003, the RBI has permitted FIIs to subscribe to shares of an Indian company in a Public Issue without prior RBI approval, so long as the price of Equity Shares to be issued is not less than the price at which Equity Shares are issued to residents.

Investors making an application in this Issue will be required to confirm and will be deemed to have represented to our Company, the LM and their respective directors, officers, agents, affiliates and representatives that they are eligible under all applicable laws, rules, regulations, guidelines and approvals to subscribe to the Equity Shares of our Company and will not offer, sell, pledge or transfer



the Equity Shares of our Company to any person who is not eligible under applicable laws, rules, regulations, guidelines and approvals to acquire Equity Shares of our Company. Our Company, the LM and their respective directors, officers, agents, affiliates and representatives accept no responsibility or liability for advising any investor whether such investor is eligible to subscribe to Equity Shares of our Company.

#### **15. Subscription by NRIs/FIIs**

It is to be distinctly understood that there is no reservation for Non-Residents, NRIs and FIIs and all Non-Residents, NRI and FIIs applicants will be treated on the same basis as other categories for the purpose of allotment.

As per the RBI regulations, OCB cannot participate in the Issue.

#### **16. Investment by Foreign Institutional Investors**

Foreign Institutional Investors ("FIIs") including institutions such as pension funds, investment trusts, asset management companies, nominee companies, institutional portfolio managers can invest in all the securities traded on the primary and secondary markets in India. FIIs are required to obtain an initial registration from the SEBI and a general permission from the RBI to engage in transactions regulated under FEMA. FIIs must also comply with the provisions of the SEBI (Foreign Institutional Investors) Regulations, 1995, as amended from time to time. The initial registration and the RBI's general permission together enable the registered FII to buy (subject to the ownership restrictions discussed below) and sell freely securities issued by Indian companies, to realise capital gains or investments made through the initial amount invested in India, to subscribe or renounce rights issues for shares, to appoint a domestic custodian for custody of investments held and to repatriate the capital, capital gains, dividends, income received by way of interest and any compensation received towards sale or renunciation of rights issues of shares.

As per the current regulations, the following restrictions are applicable for investments by FIIs, the allotment of Equity Shares to a single FII should not exceed 10% of the post-issue paid-up capital of our Company. In respect of an FII investing in Equity Shares of our Company on behalf of its sub-accounts, the investment on behalf of each sub account shall not exceed 10% of our Company total issued capital or 5% of our Company total issued capital in case such sub account is a foreign corporate or an individual.

The above information is given for the benefit of the Applicants. Our Company and the LM are not liable for any amendments or modification or changes in applicable laws or regulations, which may happen after the date of the Prospectus. Investors are advised to make their independent investigations and ensure that the number of Equity Shares applied for do not exceed the applicable limits under laws or regulations.

The Equity Shares have not been and will not be registered under the Securities Act, 1993 or any state securities laws in the United States and may not be offered or sold within the United States or to, or for the account or benefit of, "U.S. persons" (as defined in Regulation S under the Securities Act), except pursuant to an exemption from, or in a transaction not subject to, the registration requirements of the Securities Act. Accordingly, the Equity Shares may be offered and sold (i) in the United States to "qualified institutional buyers" as defined in Rule 144A of the Securities Act, and (ii) outside the United States to certain persons in offshore transactions in compliance with Regulation S under the Securities Act and the applicable laws of the jurisdiction where those offers and sales occur.





## SECTION IX: MAIN PROVISIONS OF THE ARTICLES OF ASSOCIATION

The main provisions of the of the Articles of Association relating to voting rights, dividend, lien, forfeiture, restrictions on transfer and transmission of Equity Shares or debentures and/or on their consolidation/splitting as detailed below

### Share capital

3. The Share Capital of our Company is Rs.30,00,00,000/- (Rupees Thirty crores only) divided into 3,00,00,000/- (Three crores only) equity shares of Rs.10/- (Rupees Ten only) each, with power to divide the shares of capital into several classes and to attach thereto respectively such qualified or special rights, privileges or conditions in such manner as may for the time being be provided by the regulations of our Company as originally framed or as altered by special resolution.
4. Subject to the provisions of Section 80 and 80A of the Act, our Company shall have power to issue any shares as Redeemable Preference Share, out of the original or subsequently created capital, and such Redeemable Preference Shares may, with the sanction of our Company in General Meeting be issued on such terms as to dividend. Preferential payment or as to terms and conditions of redemption.
5. Except as provided by section 77 of the Act, no part of funds of our Company shall be employed in the purchase of shares of Company and our Company shall not give, whether directly or indirectly and whether by means of a loan guarantee, the provision of security or otherwise, any financial assistance for the purpose of or in connection with the purchase of or subscription made or to be made by any person or for any shares in our Company or its holding Company.
6. Our Company shall commence business or exercise any borrowing power only after the requirements of section 149 of the Act, shall have been complied with.
7.
  - 1) The Board may, at any time increase the subscribed capital of our Company by issue of new shares out of the unused part of the share capital in the original or subsequently created capital, but subject to section 81 of the Act, and the following provisions namely.
    - a) Where the offer and allotment of such shares are made within two years from the date of incorporation of our Company or within one year from the first allotment of shares made after its incorporation, whichever is earlier, the Board shall be at liberty to offer the shares and allot the same to any person or persons at their discretion.
    - b) In respect of offers and allotments made subsequent to the date set out in clause (a) above, the directors shall subject to the provisions of section 81 of the Act and of subclause (c) hereunder observe the following condition.
      - i) Such new shares shall be offered to the persons who at the date of the offer, are holders of equity shares of our Company, in proportion as nearly as circumstances admit, to the Capital paid-up on these shares at the date.
      - ii) The offer aforesaid shall be made by notice specifying the number of shares offered and limiting a time not being less than thirty days from the date of the offer within which the offer if not accepted will be deemed to have been declined.
      - iii) The offer aforesaid shall be deemed to include a right exercisable by the person concerned to renounce the shares offered to him or any of them in favour of any other person, and the notice referred to in clause(ii) shall contain a statement of this right.
      - iv) After the expiry of the time specified in the notice aforesaid or earlier intimation from the person to whom such notice is given that declines to accept the shares offered the Board may dispose of them in such manner as it think most beneficial to our Company.
    - c) The Directors may with the sanction of our Company in General Meeting offer and allot shares to any person at their discretion provided that such sanction is accorded either by:
      - i) a special resolution passed at any General Meeting, or
      - ii) by an ordinary resolution passed at a General Meeting by majority of the votes cast and with the approval of the Central Government in accordance with section 81 of the Act.



- 2) Nothing in this clause shall apply to the increase of the subscribed capital of our Company caused by the exercise of an option attached to debentures issued or loans raised by our Company .
  - i) to convert such debentures or loans into shares in our Company , or
  - ii) to subscribe for shares in our Company .

Provided that the terms of issue of such debentures or the term of such loans include a term providing for such option and such term:

- a) has been approved by a special resolution passed by our Company in General Meeting before the issue of the debentures of the raising of the loans, and also.
- b) either has been approved by the Central Government before the issue of the debentures or the raising of the loans or is conformity with the rules, if any, made by that Government in this behalf.

- 3) option or right to call of shares shall not be given to any persons except with the sanction of our Company in General Meeting.

8. In addition to and without derogating from the powers for that purpose for that purpose conferred on the Board under Article 7 of our Company in General Meeting may determine that any shares (whether forming part of the original capital or of any increased capital of our Company ) shall be offered to such persons (whether members or holders of debentures of our Company or not) in such proportions and on such terms and conditions either at premium or at par, or (subject to compliance with the provisions of section 79 of the Act) at a discount, such option being exercisable at such times and for such consideration as may be directed by such General Meeting or our Company in General Meeting may make any other provisions whatsoever for the issue, allotment or disposal of any shares.
9. The rights attached to each class of shares (unless otherwise provide by the terms of issue of the shares of the class) may, subject to the provision of sections 106 and 107 of the Act, be varied with the consent in writing of the holders of three fourths of the issued shares of that class or with the sanction of a special resolution passed at a separate meeting of the holders of the shares of that class. To every such separate meeting, the provisions, of these Articles relating to General Meeting shall mutates mutandis apply, except that the necessary quorum shall be two persons at least holding or representing by proxy one-third of the issued shares of that class.
10. The rights conferred upon the holders of the shares of any class issued with preferred or other rights of that class, shall no, unless expressly otherwise provided by the conditions of issued of that class of shares be deemed to be varied by the creation or issue of further shares ranking pari passu therewith.
11. Our Company shall not issue any shares not being Preference Shares which carry voting rights or right in our Company as to dividend, capital or otherwise which are disproportionate to the rights attached to the holders of other shares ot being preference shares.
12.
  - 1) Subject to the provisions of Section 76 of the Act our Company may at any time pay a commission to any person for subscribing or agreeing to subscribe whether absolutely or conditional for any shares debentures, or debenture-stock of our Company or procuring or agreeing to procure subscription whether absolute or conditionally for shares, debentures or debenture-stock of our Company but so that the statutory conditions ad requirements shall be observed and complied with and the amount of rate of commission shall not exceed five percent of the price at which the shares are issued and in case of debentures the rate of commission shall not exceed two-and-a half percent of the price at which debentures are issued.
  - 2) Our Company , may also, on any issue, pay such, brokerage as may be lawful.
13. The Directors may allot and issue shares in the Capital of our Company as payment or part payment for any property sold or transferred, goods or machinery and appliances supplied, or for services rendered to our Company in or about formation of promotion of our Company of the acquisition ad or conduct of its business and any shares which may be so allotted, may be issue as fully paid up shares, and if so issued shall be deemed to be fully paid up shares.



13 (A) FURTHER ISSUE OF SHARES.

1. Where at the time after the expiry of two years from the formation of our Company or at any time after the expiry of one year from the allotment of shares in our Company made for the first time after its formation, whichever is earlier, it is proposed to increase the subscribed capital of our Company by allotment of further shares either out of the un-issued capital or out of the increased share capital then:
  - a) Such further shares shall be offered to the persons who at the date of the offer, are holders of the equity shares of our Company, in proportion, as near as circumstances admit, to the capital paid up on those shares at the date.
  - b) Such offer shall be made by a notice specifying the number of shares offered and fixing a time not less than thirty days from the date of the offer and the offer if not accepted, will be deemed to have been declined.
  - c) The offer aforesaid shall be deemed to include a right exercisable by the person concerned to renounce the shares offered to them in favour of any other person and the notice referred to in sub clause (b) hereof shall contain a statement of this right. PROVIDED THAT the Directors may decline, without assigning any reason to allot any shares to any person in whose favour any member may, renounce the shares offered to him.
  - (d) After expiry of the time specified in the aforesaid notice or no receipt of earlier intimation from the person to whom such notice is given that the declines to accept the shares offered, the Board of Directors may dispose of them in such manner and to such person(s) as they may think, in their sole discretion fit.
2. Notwithstanding anything contained in sub-clause (1) thereof, the further shares aforesaid may be offered to any person (whether or not those persons include the persons referred to in clause (a) of sub-clause(1) hereof in any manner whatsoever.
  - a) If a special resolution to that effect is passed by our Company in General Meeting or
  - b) Where not such special resolution is passed, if the votes cast (whether on a show of hands or on a poll as the case may be) in favour of the proposal contained in the resolution moved in the general meeting (including the casting vote, if any, of the chairman) by the members who, being entitled to do so, vote in person, or, where proxies are allowed, by proxy, exceed the votes, if any, cast against the proposal by members, so entitled and voting and the Central Government is satisfied, on an application made by the Board of Directors in this behalf that the proposal is most beneficial to our Company.
3. Nothing in sub-clause(c) of (1) hereof shall be deemed:
  - (a) to extend the time within which the offer should be accepted; or
4. Nothing in this Article shall apply to the increase of the subscribed capital of our Company caused by the exercise of an option attached to the debenture issued or loans raised by our Company :
  - (i) To convert such debentures or loans into shares in our Company ; or
  - (ii) To subscribe for shares in our Company (whether such option is conferred in these Articles or otherwise)

**PROVIDED THAT** the terms of issue of such debentures or the terms of such loans include a term providing for such option and such term:

- (a) Either has been approved by the Central Government before the issue of the debentures or the raising of the loans or is in conformity with Rules, if any, made by that Government in this behalf; and
- (b) In the case of debentures or loans or other than debentures issued to or loans obtained from Government or any institution specified by the Central Government in this behalf, has also been approved by a special resolution passed by our Company in General Meeting before the issue of the debentures or raising of the loans.

**SHARES AT THE DISPOSAL OF THE DIRECTORS**

- 13 (B) Subject to the provisions of Section 81 of the Act and these Articles, the shares in the capital of our Company for the time being shall be under the control of the Directors who may issue, allot or otherwise dispose of the same or any of them to such persons, in such proportion and on such terms and conditions and either at a premium or at par or (subject to the compliance with the provisions of section 79 of the Act) at a discount and at such time as they may from time to time think fit and with the sanction of our Company in the General Meeting to give to any person or persons the option or right to call for any shares either at par or premium during such time and for such consideration as the Directors think fit, and may issue and allot shares in the capital of our Company on payment in full or part of any property sold and transferred or for any services rendered to our Company in the conduct of its business and any shares which may so be allotted may be issued as fully paid up shares and if so issued, shall be deemed to be fully paid shares. Provided that option or right to call of shares shall not be given to any person or persons without the sanction of our Company in the General Meeting.

**JOINT HOLDERS**

14. Where two or more persons are registered as the holders of any share they shall be deemed to hold the same as joint-holders with benefit of survivorship subject to the provisions following and to the other provisions of these Articles relating to joint holders.
- a) Our Company shall not be bound to register more than three persons as joint holders of any share.
  - b) The person whose name stands first on the register in respect of such share shall alone be entitled to delivery of certificate thereof.
  - c) Any one of such persons may give effectual receipts for any dividend, bonus or return of capital payable in respect of such share, and such joint holders shall be severally as well as jointly liable for payment of all installments and calls due in respect of such share / shares.
  - d) Any one of such persons may vote at any meeting either personally or by proxy in respect of such shares, as if he were solely entitled thereto, and if more than one of such joint holders be present at any meeting personally or by proxy, that one of the said persons so present whose name stands first on the register in respect of such share, shall alone be entitled to vote in respect thereof, Several executors or administrators, of a deceased member in whose name any share stands shall for the purpose of this articles, be deemed as joint holders.
  - e) In case of death of any one or more of such joint holders, the survivors shall be the only persons recognized by our Company as having any title to or interest in such share, but the Director may require such evidence of death as they may deem fit, and nothing herein contained shall be taken to release the estate of a deceased joint holder from any liability on shares held by him jointly with any other person.
  - f) All notices directed to be given to the members shall be given to whichever such persons is named first in the register and notice so given shall be sufficient notice to all the holders of such shares.

**SHARE CERTIFICATES**

15. Every certificate of title to shares shall be issued under the seal of our Company . Every share certificate and every document of title to the whether in renewal of an existing share certificate or other document of title or issued for the first time shall be issued, under the authority of the Board of Directors and in accordance with provisions of the Companies Act (issue of share certificate) Rules, 1960 or any modification thereof and in accordance with the provisions of law or other rule having the force of law applicable thereto.

- A) Limitation of time for issue of Certificate:

Every member shall be entitled, without payment, to one or more certificates in marketable lots, for all the shares of each class or denomination registered in the name, or if the Directors so approve (upon



paying such fee as the Directors may from time to time determine) to several certificates, each for one or more of such shares and our Company shall complete and have ready for delivery such certificates within three months from the date of allotment, unless the conditions of issue thereof otherwise provide, or within one month of the receipt of application or registration of transfer, transmission, sub-division, consolidation or renewal of any of its shares as the case may be. Every certificate of shares shall be under the seal of our Company and shall specify the number and distinctive numbers of shares in respect of which it is issued and amount paid-up thereon and shall be in such form as the directors may prescribe or approve, provided that in respect of a share or shares held jointly by several persons our Company shall not be borne to.

16.
  - 1) Every person whose name is entered as a member in the register shall be entitled to receive without payment.
    - a) One certificate for all his shares; or
    - b) Where the shares so allotted at any one time exceed the number of shares fixed as marketable lot in accordance with the usages of the stock exchange, or at the request of the share holder, several certificates one each per marketable lot and one for the balance.
  - 2) Our Company shall within ten weeks of the closer of subscription list or within one month after application for the registration of the transfer of any shares or debentures complete and have ready for delivery, the certificate for all the shares and debentures so allotted or transferred unless the conditions of issue of the said shares or debentures otherwise provide.
  - 3) Every certificate shall be under the seal and shall specify the shares or debentures to which it relates and the amount paid up thereon.
  - 4) The provisions of clauses (2) and (3) above shall apply mutatis mutandis to debentures and debenture stock allotted or transferred.
  - 5) No fee shall be charged for the issue of a new share certificate either for subdivision of the existing share certificate or for consolidation of several share certificates into one or for issue of fresh share certificates on the back of which there is no space for endorsement for transfer or for registration of any Probate, Letters of Administration, Certificate of like document or for registration of any Power of Attorney Partnership Deed, or other similar documents.
17. In respect of any transfer of shares registered in accordance with the provisions of these Articles, the Board may, at their discretion direct an endorsement of the transfer and the name of the transferee and other particulars, on the existing share certificate and authorise any Director or Officer of our Company to authenticate such endorsement on behalf of our Company or direct the issue of a fresh share certificate, in lieu of and in cancellation of the existing certificate, in the name of the transferee.

#### **ISSUE OF NEW CERTIFICATE IN PLACE OF ONE DEFACED, LOST OR DESTROYED**

18. If any certificate be worn out, defaced, mutilated, or torn or if there be no further space on the back thereof for endorsement of transfer, then upon production and surrender thereof to our Company, a new certificate may be issued in lieu thereof and if any certificate lost or destroyed then upon proof thereof to the satisfaction of our Company and on execution of such indemnity as our Company deem adequate, being given, a new certificate in lieu thereof shall be given to the party entitled to such lost or destroyed certificate. Every certificate under the Article shall be issued without payment of fees if the Directors so decide, or on payment of such fees (not exceeding Rs.2/- of each certificate) as the Directors shall prescribe. Provided that no fee shall be charged for issue of new certificates in replacement of those which are old, defaced or worn out or where there is no further space on the back thereof for endorsement of transfer.

Provided that notwithstanding what is stated above the Directors shall comply with such Rules or Regulation or requirements of any Stock Exchange or the Rules made under the Act or the Rules made under Securities Contracts (Regulation) Act-1956 or any other Act, or rules applicable in this behalf.

The provision of this Article shall mutatis mutandis apply to debentures of our Company.

**DEMATERIALIZATION OF SECURITIES****18 (A).****A. Definition:**

For the purpose of this Article:

1. Beneficial owner: Means a person or persons whose name is recorded as such with a depository.
2. "SEBI" means Securities & Exchange Board of India.
3. Depository: Means a Company formed and registered under the Companies Act-1956 and which was been granted a certificate of registration to Act, as a depository under the Securities & Exchange Board of India Act, 1992, and Security means such security as may be specified by SEBI from time to time.

**B. Dematerialisation of Securities:**

**NOTWITHSTANDING ANY** thing contained in these Articles, our Company shall be entitled to dematerialize its securities and to offer securities in a dematerialization from pursuant to the Depositories Act, 1996.

**C. Options for Investors:**

Every person subscribing to securities offered by our Company shall have the option to receive Security Certificates to hold the Securities with a Depository. Such a person who is the beneficial owner of the securities can at any time opt out of a depository, if permitted by the law, in respect of any security in the manner provided by the Depositories Act-1956 and our Company, shall in the manner and within the time prescribed, issue to the beneficial owner the required certificate of Securities. If a person opts to hold his security with a depository, our Company shall intimate such depository the detail of allotment of the security.

**D. Rights of depositories and beneficial owner:**

All Securities held by a depository shall be dematerialised and be in fungible form. Nothing contained in section 153, 153-A, 153-B 187-C and 372 of the act, shall apply to depository in respect of the securities held by it on behalf of the beneficial owner.

**E Rights of depositories and beneficial owner:**

- i. Notwithstanding anything to the contrary contained in the act, or these Articles, a depository shall be deemed to be the registered owner for the purposes of effecting transferred or ownership of security on behalf of the beneficial owner.
- ii. Save as otherwise provided in (i) above, the depository as the registered owner of the securities shall not have any holding rights or any other rights in respect of the securities held by it.
- iii. Every person holding securities of our Company and whose name is entered as the beneficial owner in the records of the depository shall be deemed to be a member of our Company, the beneficial owner of securities shall be entitled to all the rights and benefits and be subject to all the liabilities in respect of his securities which are held by depository.
- iv. Service of documents:  
Notwithstanding anything in the Act, or these articles to the contrary, where securities are held in a depository, the records of the beneficial ownership may be served by such depository on our Company by means of electronic mode or by delivery of floppies or discs.
- v. Transfer of securities:  
Nothing contained in Section-108 of the Act, or these articles shall apply to a transfer of securities effected by transferor and transferee both of whom are entered as beneficial owners in the records of a depository.



vi. Allotment of securities dealt with in a depository:

Notwithstanding anything in Act, or these articles, where securities are dealt with by a depository, our Company shall intimate the details thereof the depository immediately on allotment of such securities.

vii. Distinctive numbers of securities held in a depository:

Nothing contained in the Act, or these articles regarding the necessity of having distinctive numbers for securities issued by our Company shall apply to securities held with a depository.

viii. Register and index of beneficial owners:

The register and Index of beneficial owners maintained by a depository under the Depository Act-1996 shall be deemed to be the Register and Index of members and Security holders of the purpose of these Article.

**19. COMPANY'S LIEN ON SHARE / DEBENTURES:**

Our Company shall have a first and paramount lien upon all the shares / debentures (other than fully paid-up shares/debentures) registered in the name of each member (Whether solely or jointly with others) and upon the proceeds of sale thereof for all moneys (whether presently payable or not) called or payable at a fixed time in respect of such shares / debentures and no equitable interest in any share shall be created except upon the footing and condition that this Article will have full effect. And such lien shall extend to all dividends and bonuses from time to time declared in respect of such shares / debentures. Unless otherwise agreed the registration of a transfer of shares / debentures shall operate as a waiver of our Company's lien if any, on such shares / debentures. The Directors may at any time declare any shares / debentures wholly or in part to be exempt from the provisions of this clause.

20. For the purpose of enforcing such lien, the Board may sell the share subject thereto in such manner as they think fit but no sale shall be made until the expiration of 14 days after notice in respect of which the lien exists has been given to the registered holder of the shares for the time being or to the person entitled to the shares by reason of the death or insolvency of the registered holder.

21. Upon any sale after forfeiture of for enforcing a lien in purported exercise of the powers before given the Board may appoint some person to execute an instrument of transfer of the shares held any cause the purchaser shall not be bound to see the regularity of the proceeding nor to the application of the purchase money, and after his name has been entered in the Register in respect of such share, the validity of sale shall not be impeached by any person, and the remedy and the aggrieved party shall exclusively deal only with our Company and claims if any shall be restricted to damages only.

22 1) The net proceeds of any such sale shall be received by our Company and applied in payment of such part of the amount in respect of which the lien exists as is presently payable.

2) The residue if any, shall subject to like lien for sums not presently payable as existed upon the shares before the sale, be paid to the person entitled to the shares at the date of the sale.

23. Any money due from our Company to a share holder, may, without the consent of such shareholder, be applied by our Company in or towards payment of any money due from him, either alone or jointly with any other person to our Company in respect of calls or otherwise.

**CALL ON SHARES.**

24. Subject to the provisions of section 91 of the Act, the Board of Directors may from time to time make such calls as they think fit upon the members in respect of all money unpaid on the shares held by them respectively whether an account of nominal value of shares or by way of premium and not by the conditions of allotment thereof made payable at fixed times, and each member shall pay the amount of every call so made on him to the persons and at the date time and place or at the date time and place or at the dates, times and places appointed by the board of Directors.



25. The Board of Directors may, when making a call be resolution determine the date of which such call shall be deemed to have been made not being earlier than the date of resolution making such calls and thereupon the call shall be deemed to have been made on the date so determined and if no such date is fixed the call shall be deemed to have been made on the date on which the resolution of the Board making the call was passed.
26. Not less than thirty day's notice of any call shall be given specifying the date time and place of payment provided that before the time for payment of such call, the Directors may, by notice in writing to the members, extend the time for payment thereof.
27. Any such which by terms of issue of share becomes payable on allotment or at affixed date, whether on account of the nominal value of the share or by way of premium shall for the purpose of the Articles, be deemed to be call duly made any payable on the date on which by the terms of issue such sum become payable, and in case of non-payment, all the relevant provisions of these Articles, as to payment of interest and expenses, forfeiture or otherwise shall apply as if such sum had become payable by virtue of a call duly made and notified.
28. 1) If a sum called in respect of the shares is not paid before or on the day appointed for payment thereof, the person from whom the sum is due shall pay interest upon the sum at such rate not exceeding 18% per annum fixed by the Board of Directors from the day appointed for the payment thereof to the time of actual payment, but the Board of Directors shall be at liberty to waive payment of that interest wholly or in part.
- 2) The provisions of this Article as to payment of interest shall apply in the case of non-payment of any sum which by the terms of issue of a share becomes payable at a fixed date, whether on account of the amount of the share or by way of premium as if the same had become payable by virtue of a call duly made and notified.

**29. PAYMENT IN ANTICIPATION OF CALL MAY CARRY INTEREST:**

The Directors may, if they think fit, subject to the provisions thereof as from time to time exceeds the amount of the calls then made upon the shares in respect of which such advances has been made, our Company may pay interest at such advance has been made, our Company may pay interest at such rate, as the member paying such sum in advance and the Directors agree upon provided that money paid in advance of calls shall not confer a right to participate in profits or divided. The Directors may at any time repay the amount so advanced.

The member shall not be entitled to any voting rights in respect of the moneys so paid by him until the same would but for such payment, become presently payable.

The Provision of these Articles shall mutatis mutandis apply to the calls on debentures of our Company.

30. Neither a Judgement nor a Decree in favour of our Company, for calls or other moneys due in respect of any share, nor any part payment or satisfaction there under, nor the receipt by our Company of a portion of any money which shall from time to time, be due from any member in respect of any share, either by way of principle or interest, nor any indulgence granted by our Company in respect of the payment of the such money, shall preclude our Company from thereafter proceeding to enforce a forfeiture of such shares as herein, after provided.
31. If, by the conditions of allotment of any share, the whole or part of the amount or issue price thereof shall be payable by installments, every such installment shall, when due, be paid to our Company by the person who for the time being and from time to time shall be registered holder of the share or his legal representative or representatives, if any,

**TRANSFER & TRANSMISSION OF SHARES**

32. The instrument of transfer of any shares in our Company shall be executed both by the transferor and the transferee and the transferor shall be deemed to remain holder of the shares until the name of the transferee is entered in the register of members in respect thereof. The instrument of transfer shall be in respect of only one class of shares and should be in the form prescribed under section 108 of the Act.





- 2) The Board of Directors shall not register any transfer of shares unless a proper instrument of transfer duly stamped and executed by the transferor and the transferee has been delivered to our Company along with the certificate relating to the shares and such other evidence as our Company may require to prove the title of the transferor or his right to transfer the shares.

Provided that where it is proved to the satisfaction of the Board of Directors that an instrument of transfer signed by the transferor and transferee has been lost, our Company, may if the Board of Directors think fit, on an application in writing made by the transferee and bearing the stamp required on an instrument of transfer, register the transfer on such terms as to indemnity, as the Board of Directors may think fit.

- 3) An application for the registration of the transfer of any share or shares may be made either by the transferor or by the transferee, provide that where such application is made by the transferor on registration shall in the case of partly paid shares be effected unless our Company gives notice of the application to the transferee and our Company shall, unless objection is made, by the transferee within two weeks from the date receipt of the notice, enter in the register the name of the transferee in the same manner and subject to the same conditions as if the application for registration was made by the transferee.
- 4) For the purpose of Sub-clause(3) notice to the transferee shall be deemed to have been duly given if dispatched by prepaid registered post to the transferee at the address given in the instrument of transfer and shall be deemed to have been delivered in the ordinary course of post.
- 5) Nothing in clause (4) shall prejudice any power of the Board to register as a shareholder any person to whom the right to any share has been transmitted by operation of law.
- 6) Nothing in the Articles shall prejudice the power of the Board Directors to refuse to register the transfer of any shares to a transferee, whether a member or not.
33. The shares in our Company shall be transferred by an instrument in writing in the prescribed form, duly stamped and in the manner provided under the provisions of section 108 of the Act and any modification thereof and the Rules prescribed thereof.

34. **DIRECTORS MAY REFUSE TO REGISTER TRANSFER:**

Subject to the provisions of Section 111 of the Act and Section 22A of the Securities Contracts (Regulation) Act-1956 the Directors may, at their own absolute and uncontrolled discretion and by giving reasons, decline to register or acknowledge any transfer of shares whether fully paid or not and the right of refusal, shall not be affected by the circumstances that the proposed transferee is already a member of our Company but in such cases, the Directors shall within one month from the date on which the instrument of transfer was lodged with our Company, send to the transferee and transferor notice of the refusal to register such transfer provided that registration of transfer shall not be refused on the ground of the transferor being either alone or jointly with any other person or persons indebted to our Company on any account whatsoever except when our Company has a lien on the shares. Transfer of share / debentures in whatever lot shall not be refused.

35. The Board of Directors may also decline to recognize any instrument of transfer unless:
- a) The instrument of transfer is accompanied by the certificate of shares to which it relates and such other evidence as the Board of Directors may reasonably require to show the right of the transferor to make the transfer and
- b) The instrument of transfer is in respect of only one class of shares.
- 1) Every endorsement upon the certificate of any share in favour of any transferee shall be signed by the Managing Director or by some other person for the time being duly authorised by the Managing Director in this behalf. In case any transferee of a share apply for a new certificate in lieu of the old or the existing certificate he shall be entitled to receive a new certificate in respect of which the said transfer has been applied for and upon his delivering for cancellation every old or existing certificate which is to be replaced by a new one.



- 2) Notwithstanding any other provisions to the contrary in these person's no fee shall be charged for any other following viz.
  - a) for registration of transfer of shares and debentures, or for transmission of shares and debentures;
  - b) for sub-division and consolidation of share and debenture certificates and for sub-division of letters of allotment and split, consolidation, renewal and pucca transfer receipts into denominations corresponding to the market units of trading.

36. For sub-division of renounceable Letters of Right.

- 1) for issue of certificates in replacement of those which are old decrepit or worn out or where the cages on the reverse for recording transfers have been fully utilised.
- 2) for registration of any power of attorney, deed, letters of administration or similar other documents.

37. Our Company shall keep a book to be called the "Register of Members" and therein shall be entered the particulars of every transfer or transmission of any share and all other particulars of shares required by the Act to be entered in such Register.

38. The instrument of transfer shall, after registration, remain in the custody of our Company, The Board may cause to be destroyed all transfer deed lying with our Company for a period of 6 years or more.

39. The Board of Directors may after giving not less than 7 days previous notice by advertisement in some news paper circulating in the district in which the Registered Office of our Company is situated close the Register of Members or the Register of debentures holders for any period or periods not exceeding in the aggregate 45 days in each year but not exceeding 30 days at any one time.

40. 1) The Executors or administrators of a deceased member not being one of several joint holders shall be the only person recognized by our Company as having any title to the shares registered in the name of such member and in the case of death of any one or more of the joint holders of any registered shares, the survivors shall be the only persons recognized by our Company as having any title to or interest in such shares.

Provided that if the member should have been a member of a joint Hindu family the Board on being satisfied to that effect and on being satisfied that the shares standing in his name in fact belonging to the joint family may recognize the survivors of the Kartha thereof as having title to the shares registered in the name of such member. Provided further in any case it shall be lawful for the Board in their absolute discretion to dispense with the production of probate or letter of administration or other legal representation upon such terms as to indemnitor otherwise as the Board may deem just.

2) Nothing in clause (1) shall release the estate of a deceased joint holder from any liability in respect of any shares which were jointly held by him with other persons.

41. 1) Any person becoming entitled to a share in consequence of the death or insolvency of a member may, upon such evidence being produced as may from time to time be required by the Board and subject as herein after provided. Elect either;

- a) to be registered himself as holder of the shares; or
- b) to make such transfer of the shares as the deceased or insolvent member could have made.

2) The Board shall, in either case, have the same right to decline or suspend registration as they would have had, if the deceased or insolvent member had transferred the shares before his death or insolvency.

#### **DEVOLUTION OF RIGHTS.**

42. 1) If the person so becoming entitled shall elect to be registered as holder of the shares himself, he shall deliver or send to our Company a notice in writing by him stating that he so elects.

2) If the person aforesaid shall elect to transfer the share, he shall testify his election by executing transfer of the share.



- 3) All the limitations restrictions and provisions of these regulations to the rights to transfer and registration of transfr of shares shall be applicable to any such notice or transfer as aforesaid as if the death or insolvency of the member had not occurred and the notice of transfer were a transfer signed by the member.
- 4) A person becoming entitled to a share by reason of the death or insolvency of the holder shall be entitled to the same dividends and other advantages to which he would be entitled if he were the registered holder of the share except that he shall not before being registered as a member in respect of the share, be entitled in respect of it to exercise any right conferred by membership in relation to meetings of our Company .

Provided that the Board may, at any time, give notice requiring any such person to elect either to be registered himself or transfer the share, and if the notice is not complied within ninety days, the Board may thereafter with hold payment of all dividends, bonuses or other money's payable in respect of the share, until the requirements of the notice have been complied with.

43. Te Company shall incur no liability or responsibility whatever in consequence of the registering or giving effect to any transfer of shares made or purpoting to be made by any apparent legal owner thereof (As shown or appearing in the register) to the prejudice of persons having or claiming any equitable right, title or interest to or in the same shares notwithstanding that our Company may have had notice of such equitable rights or referred thereto in any books of our Company and our Company shall not be bound by or required to regard or attend to or give effect to any notice which may be given to it of any equitable rights title or interest or be under any liability whatsoever for refusing or neglecting so to do through it may have been entered or referred to in the books of our Company , but our Company shall nevertheless be at liberty to have regard and attend to any such notice and give effect thereto, if the Board shall think fit.

#### **FORFEITURE OF SHARES.**

44. If a member fails to pay any call or installment of call on the day apponted for the payment thereof, the Board of Directors may at anytime thereafter during such time as any part of such a call or installment remains unpaid serve nvice on him requiring payment of so much of the call or installment as is unpaid, together with any interest, which may have accrued.
45. The notice shall name a further day (not earlier than the expiration of fourteen days from the date of service of notice) on or before which the payment required by the notice is to be made, and shall state that in the event of non-payment on or before the day named the shares in respect of which the call was made will be liable to be forfeited.
46. If the requirements of any such notice as aforementioned are not complied with, any share in respect of which the notice has been given may at anytime thereafter before the payment required by the notice has been made, be forfeited by a resolution of the Board of Directors to that effect. Such forfeiture shall include all dividends declared in respect of the forfeited shares and not actually paid before the forfeiture.
47. A forfeited share may be sold or otherwise disposed of on such terms and in such manner as the Board of Directors may think fit, and at any time before a sale or disposition, the forfeiture may be cancelled on such terms as the Board of Directors may think fit.
48. A person whose shares have been forfeited shall cease to be a member in respect of the forfeited shares but shall notwithstanding remain liable to pay and shall forthwith pay our Company all money's which at the date of forfeiture were presently payayble by him to our Company in respect of the shares but his liability shall cease if and when our Company , received payment in full of such money's in respect of the shares.
49. i) A duly verified declaration in writing that the declarant is a director of our Company that a share in the company has been duly forfeited a date stated in the declaration shall be conclusive evidence of the facts therein stated as against all persons claiming to be entitled to the shares and that declaration and receipt of our Company for the consideration if any given for the shares on the sale or disposition thereof shall constitute a good title to the share, and the person to whom



the share is sold or disposed of shall be registered as the holder of the share and shall not be bound to see to the application of the purchase money (if any) nor shall his title to the shares be affected by way of irregularity or invalidity in the proceedings in reference to the forfeiture, sale, or disposal of the share.

- ii) Where any share, under the powers in the behalf herein contained, is forfeited by the Board, and the certificate in respect thereof has not been delivered to our Company by the former holder of such share, the Board may issue a new certificate for such share, distinguishing it in such manner as it may think fit from the Certificate not so delivered up.

50. The provisions of these regulations as to forfeiture shall apply in the case of no payment of any sum which by the terms of issue share, become payable at a fixed time, whether, on nominal account of the amount of the share, or by way of premium or otherwise as if the same had been payable by virtue of a call duly made and notified.

### **CONVERSION OF SHARES INTO STOCK**

51. Our Company may by ordinary resolution convert all or any of its fully paid-up shares of any denomination into stock and vice versa.

52. The holders of stock may transfer the same or any part thereof in the same manner, as and subject to the same regulations under which, the shares, from which the stock arose might before the conversion have been transferred, or as near thereto as circumstances admit,

Provided that the Board may, from time to time, fix the minimum amount of stock transferable, so however that such minimum shall not exceed the nominal amount of the shares from which the stock arose.

53. The holders of stock shall according to the amount of stock held by them have the same rights privileges and advantages as regards dividends voting at meetings of our Company, and other matter, as if they held the shares from which the stock arose, but not such privileges or advantages (except participation in the dividends and profits of our Company and in the assets on winding up) shall be conferred by an amount of stock which would not, if existing in shares, have conferred that privilege or advantage.
54. Such of the regulations contained in these presents (other than those relating to the share warrants) as are applicable to paid up shares shall apply to stock and the words "share" and "share holder" in these presents shall include 'stock holder' in these presents shall include stock and 'stock holder' respectively.

### **ALTERATION OF CAPITAL**

55. Our Company may from time to time but subject to the provisions of Section 94 of the Act, after the conditions of its Memorandum as follows:

- a) Increase its share capital by such amount as it thinks expedient by issuing new shares.
- b) Consolidate and divide all or any of its share capital into shares of larger amount than its existing shares.
- c) Convert all or any of its fully paid-up shares into stock, and reconvert that stock into fully paid up shares of any denominations:
- d) Sub-divide its shares, or any of them, into shares of smaller amount than is fixed by the Memorandum, so however that in the sub-division the proportion between the amount, if any unpaid on each reduced share shall be the same as it was in the case of the share from which the reduced is derived.
- e) Cancel any shares which, at the date of the passing of the resolution in the behalf have not been taken or agreed to be taken by any person, and diminish the amount of its share capital by the amount of the shares so cancelled.
- f) The resolution whereby any share is sub-divided may determine that as between the holders of the shares resulting from such sub-division one or more of such shares shall have some preference or special advantage as regards dividend, capital, voting or otherwise over or as compared with others.



56. The new shares shall be subject to the same provisions with reference to the payment of calls, lien, transfer, transmission, forfeiture and otherwise as the shares in the original share capital.
57. Our Company may by Special Resolution, reduce in any manner and with, and subject to, any incident authorised and consent required by law:
  - a) its share capital;
  - b) any capital redemption reserve account; or
  - c) any share premium account.

#### **SHARE WARRANTS.**

58.
  - 1) Our Company may issue share warrants subject to and in accordance with the provisions of Sections 114 and 115 of the Act, and accordingly the Board may in their discretion, with respect to any share registered as fully paid-up, on application in writing signed by the person registered as holder of the share and authenticated by such evidence, if any, as the Board may, from time to time, require as to the identity of the person signing the application, and on receiving the certificate, if any, of the share and the amount of the stamp duty on the warrant and such fee as the Board may from time to time, prescribe issue a share warrant and may provide by coupons or otherwise for the payment of the future dividends on the shares specified in the share warrant.
  - 2) A share warrant shall entitle the bearer to the shares included in and the shares shall be transferred by the delivery of the share warrant and the provisions of these presents with respect of transfer and transmission of shares shall not apply thereto.
  - 3) The bearer of share warrant shall, on surrender of the warrant of the Company of cancellation and on payment of such fee as the Board may from time to time prescribe, be entitled to have his name entered as a member in the Register of members in respect of the shares included in the warrant.
59.
  - 1) The bearer of a share warrant may at any time deposit the warrant at the Registered Office of our Company and so long as the warrant remain so deposited the depositor shall have the same right of signing a requisition for calling a meeting of our Company and of attending a voting and exercising the other privileges of a member at any meeting held after the expiry of two clear days from the time of deposit as if his name were inserted in the Register of Members as the holder of the shares included in the deposited warrant.
  - 2) Not, more than one person shall be recognized as depositor of the share warrant.
  - 3) Our Company shall on two days written notice return the deposited share warrant to the depositor.
60.
  - 1) Subject as herewith otherwise expressly provided, no person shall as bearer of a share warrant sign a requisition for calling a meeting of our Company, or attend or exercise any other privileges of a member at a meeting of our Company, or be entitled to receive any notice from our Company.
  - 2) The bearer of a share warrant shall be entitled in all other respects the same privileges and advantages as if he was named in the Register of members as the holder of the share included in the warrant and he shall be a member of Company.
61. The Board may, from time to time make rules as to the terms on which, if they shall think fit, a new warrant or coupon may be issued by way of renewal in case of defacement, loss or destruction of the original warrant or coupon.

#### **61(A) TERM OF ISSUE OF DEBENTURE:**

Any debentures, debenture-stock or other securities may be issued at a discount, premium or otherwise and may be issued on condition that they shall be convertible into shares of any denomination and with any privileges and condition as to redemption, surrender, drawing, allotment of Directors and otherwise Debentures with the right to conversion into or allotment of shares shall be issued only with the consent of our Company in the General Meeting by a Special Resolution.

**GENERAL MEETINGS**

62. Our Company shall in addition to other meetings hold a general meeting which shall be styled as its Annual General Meeting at intervals and in accordance with the provisions specified below:
- a) The First Annual General Meeting of our Company shall be held with eighteen months of its incorporation.
  - b) Thereafter an Annual General Meeting of our Company shall be held once in every calendar year within 6 months after the expiry of each financial year subject however to the power of the Register of Companies to extend the time within which such a meeting can be held for a period not exceeding 3 months and subject thereto not more than fifteen months shall elapse from the date of one annual meeting and that of the next.
  - c) Every Annual General Meeting shall be called for at a time during the business hours on a day that is not a public holiday and shall be held either at the Registered Office of our Company or at some other place within the city, town or village in which the Registered Office of our Company is situated.
  - d) Notice calling such meetings shall specify them as the Annual General Meetings.
  - e) All other meetings shall be referred to as Extra-ordinary General Meetings.
63. The Board of Directors may, whenever they think fit, convene an Extra-ordinary General Meeting at such time and at such places as they deem fit.
64. a) The Board of Directors shall on the requisition of such number of members of our Company as is specified below proceed duly to call an extra-ordinary General Meeting of our Company and comply with the requisition provisions of the Act in relation to meetings on.
- b) The requisition shall set out matters for consideration of which the meeting is to be called, shall be signed by the requisitionists, and shall be deposited at the Registered Office of our Company or send to our Company by registered post addressed to our Company at its Register Office.
  - c) The requisition may consist of several documents in like form, each signed by one or more requisitionists.
  - d) The number of members entitled to requisition a meeting with regard to any matter shall be such number of them holding at the date of the deposit or dispatch to the Registered Office of the requisition not less than 1/10th of such of the paid up capital of our Company as at that date carries the right of voting in regard to the matters set out in the requisition.
  - e) If the Board of Directors do not, within twenty one days from the date of deposit of requisition with regard to any matter, proceed duly to call a meeting for the consideration of those matters on a date not later than 45 days from the day of deposit of the requisition, the meeting may be called by the requisitionists themselves or such of the requisitionists as represent either majority in value of the paid up share capital held by all of them or not less than 1/10th of such paid up capital of our Company as is referred to in sub clause (d) above, whichever is less.
65. General Meeting of our Company may be called by giving not less than 21 days notice in writing provided that a General Meeting may be called after giving shorter notice, if consent thereto is accorded in the case of the Annual General Meeting by all the members entitled to vote thereat and in the case of any other meeting, by members of our Company holding not less than 95% of that part of the paid-up share capital which gives the right to vote on the matters to be considered at the meeting provided that where any members of our Company are entitled to vote only on some resolution or resolutions to be moved at a meeting and not on the others, those members shall be taken into account for purpose of this Article in respect of the former resolution or resolutions and not in respect of the latter.
66. The accidental commission to give notice of any meeting to or the non-receipt of any such notice by any of the members shall not invalidate the proceedings of or any resolution passed at such meeting.



67. Where the notice of the general meetings is given by advertising the same in a newspaper circulating in the neighborhood of the office under section 53(3) of the Act, the statement of material facts referred to in Section 173(2) of the Act, need not be annexed to the notice, as required by that section but it shall be mentioned in the advertisement that the statement has been forwarded to such persons, as are under these articles, entitled to receive such notice from our Company .

#### **PROCEEDINGS AT GENERAL MEETINGS**

68. Five members personally present shall be a quorum for a General Meeting and no business shall be transacted at any general meeting unless the requisite quorum is present at the commencement of the business.
69. If within half an hour from the time appointed for the Meeting a quorum is not present, the meeting, if called upon by the requisition of members, shall be dissolved; in any other case, it shall stand adjourned to the same day of the next week at the same time and place or such other time and place as the Board may determine and if at the adjourned meeting, a quorum is not present within half an hour from the time appointed for the Meeting, the members present shall be quorum.
70. The Chairman, if any, of the Board of Directors shall preside as a Chairman at every General Meeting of our Company .
71. If there is no such chairman, or if at any meeting he is not present within 15 minutes after the time appointed for holding the meeting or is unwilling to act as chairman, the Vice Chairman of the Board shall preside as Chairman at the General Meeting of our Company . If there is no such Vice Chairman of the Board or is not present within fifteen minutes after the time appointed for holding the meeting or is unwilling to act as chairman, the Directors present shall choose another Director as chairman and if no Directors be present or if all the Directors decline to take the chair, then the members present shall choose some one of their number to be Chairman.
72. The Chairman may, with the consent of any meeting at which a quorum is present (and shall, if so directed by the meeting) adjourn that meeting from time to time and other than the business left unfinished at the meeting from which the adjournment took place. When a meeting is adjourned for 30 days or more, notice of the adjourned meeting shall be given as in the case of original meeting. Save as aforesaid, it shall not be necessary to give any notice of any adjournment or of the business to be transacted at an adjourned meeting.
73. At any General Meeting a resolution put to the vote of the meeting shall be decided on a show of hands unless a poll is (before or on the declaration of the result of the show of hands) demanded in accordance with the provisions of Section 179 of the Act. Unless a poll is so demanded, a declaration by the Chairman, that resolution, on a show of hands, has been carried unanimously or by a particular majority or lost and an entry to that effect in the book containing minutes of the proceedings of our Company shall be conclusive evidence of the fact without proof of the number or proportion of the votes recorded in favour of, or against that resolution.
74. If a poll is duly demanded in accordance with the provisions of Section 179 of the Act, it shall be taken in such manner as the Chairman in accordance with the provision of Sections 184 and 185 of the Act direct and the results of the poll shall be deemed to be the decision of the meeting on the resolution of which the poll was taken.
75. In the case of any equality of votes, the Chairman, shall, both on a show of hands and on a poll, have a casting vote in addition to the vote or votes to which he may be entitled to as a member.
76. A poll demanded on the election of chairman or on a question of adjournment shall be taken forthwith. A poll demanded on any other question shall be taken at such time not being later than 48 hours from the time when demand was made, as the Chairman may direct.

#### **VOTE OF MEMBERS**

77. 1) Every member holding any equity shares shall have a right to vote in respect of such shares on every resolution placed before the meeting. On a show of hands every such member present in person shall have one vote. On a poll, his voting right in respect of his equity shares shall be in proportion to his share of the paid-up capital in respect of the equity shares.



- 2) In the event of Company issuing any preference shares, the holders of such preference shares shall have the voting rights set out in the behalf in section 87 of the Act.
78. A demand for a poll shall not prevent the continuance of a meeting, for the transaction of any business other than on which a poll has been demanded. The demand for a poll may be withdrawn at any time by the person who made the demand.
79. In the case of joint holders, the vote of the first named of such joint holders who tenders a vote whether in person or by proxy shall be accepted to the exclusion of the votes of the other joint holders.
80. A member of unsound mind or in respect of whom an order has been made by any Court having jurisdiction in lunacy may vote, whether on a show of hands or on a poll, by his committee or other legal guardian and any such committee or guardian may on a poll, vote by proxy.
81. No member shall be entitled to vote in any general meeting unless all calls or other sums presently payable by him in respect of his shares in our Company have been paid.
82. On a poll, votes may be given either personally or by proxy.
83. Any member entitled to attend and vote at a meeting of our Company shall be entitled to appoint any person whether a member or not as his proxy to attend and vote instead of himself, but the proxy so appointed shall not unless he be a member have any right to speak at the meeting and shall not be entitled to vote except on a poll.
84. 1) The instrument appointing a proxy shall be in writing under the hand of the appointor or his attorney duly authorized in writing or if the appointor is a Corporation either under the common seal or under the hand of an officer or attorney so authorized.
- 2) A Corporate body (whether a company within the meaning of the Act or not) may, if it is a member or a creditor or a debenture holder of our Company, by resolution of its Board of Directors or other governing body authorize such person as it thinks fit in accordance with the provisions of Section 187 of the Companies Act to act as its representatives at any meeting of our Company or at any meeting of any class of members of our Company or at any meeting of the creditors of our Company held in pursuance of the provision contained in any Debenture or Trust Deed as the case may be. The person so authorized by resolution as aforesaid shall be entitled to exercise the same rights and powers (including the right to vote by proxy) on behalf of the body corporate which he represents, as that body could exercise if it were an individual member, creditor or holder of debentures of our Company.
- 3) So long as an authorization clause (2) above is in force the power to appoint proxy shall be exercised by the person so appointed as representative.
85. The instrument appointing a proxy and the power of attorney or other Proxy to be authority if any, under which it is signed or notarially certified copy of deposited at that power of authority shall be deposited at the Registered Office of the Office Company not less than 48 hours before the time for holding the meeting or adjourned meeting at which the person named in the instrument proposed to vote, or in the case of a poll, not less than 24 hours before the time appointed for the taking of the poll and in default the instrument of proxy shall not be treated as valid.
86. A vote given in accordance with the terms of an instrument of proxy shall be valid, notwithstanding the previous death of the principal or the revocation of the proxy or the transfer of the share in respect of which the proxy is given. Provided that no intimation in writing of the death, revocation or transfer shall have been received at the Registered Office of our Company before the commencement of the meeting or adjourned meeting at which the proxy is used.
87. Every instrument appointing a proxy shall be retained by our Company and shall be either of the forms specified in Schedule IX of the Act or a form as near thereto as circumstances admit.
88. Subject to the proviso of the Act, the chairman of a General Meeting shall be the sole and absolute judge of the validity of every vote tendered at such meeting and may allow or disallow any vote tendered, according as he shall be of opinion that the same is or is not valid.



**BOARD OF DIRECTORS**

89. Unless otherwise determined by a General Meeting the number of Directors shall not be less than three and more than twelve.
90. The persons herein after named shall become and be the first Directors of Company.
1. Sri K. Balakrishna Rao
  2. Sri B.K. Sarma
  3. Sri V. Sekhar
91. Any person whether a member of our Company or not may be appointed as a Director and no qualification by way of holding shares shall be required of any Director.
92. Any person whether a member of our Company or not may be appointed as a Director and no qualification by way of holding shares shall be required of any Director.
93. The Board of Directors shall have power at any time, and from time to time appoint one or more persons as additional Directors, provided that the number of Directors and additional directors together shall not exceed the maximum number fixed. Additional Director so appointed shall hold office up to the date of the next Annual General Meeting, but he shall be eligible for election by our Company at the meeting.
94. The Board of Directors may appoint an Alternate Director to act for a Director (herein after called the original Director) during the absence of the original Director for a period of not less than three months from the state in which the meetings of the Board are ordinarily held. An alternate Director so appointed shall vacate office if any when the original Director return to the State in which meetings of the Board are ordinarily held. If the term of Office of the original Director is determined before he so returns to the State aforesaid, any provision for the automatic reappointment of returning Director in default of another appointment shall apply to the original and not to the Alternate Director.
95. a) Notwithstanding anything to the contrary contained in the Articles so long as any moneys remain owing by our Company to any Finance Corporation or Credit Corporation or to any other Financing Company or body out of any loans granted by them to our Company or so long as any Finance Corporation or Credit Corporation or any other Company or body (herein after in this article referred to as "the Corporation") continue to hold shares or debentures in our Company as a result of underwriting or direct subscription or private placement or so long as any liability of our Company arising out of any guarantee furnished by the Corporation on, behalf of our Company remains outstanding the Corporation shall have a right to appoint from time to time of non-whole time. "Nominee Director's" on the Board of our Company and to remove from such office any person or persons so appointed and to appoint any person or persons in his or their place/s.
- b) The Board of Directors of our Company shall have no power to remove from office the Nominee Director/s. At the option of the Corporation such Nominee/Director/s shall not be required to hold any share qualification in our Company. Also at the option of the Corporation such Nominee Director/s shall not be liable to retirement by rotation of Directors subjects as aforesaid, the Nominee Director's shall be entitled to the same rights and privileges and be subject to the obligations as any other Director of our Company .
- c) The Nominee Director/s appointed shall hold the said office only so long as any moneys remain owing by our Company to the Corporation or so long as the Corporation holds debentures in our Company as a result of underwriting or direct subscription or so long as the Corporation holds shares in our Company as result of underwriting or direct subscription or the liability of our Company arising out of any guarantee is outstanding and the Nominee director's so appointed in exercise of the said power shall if so facto vacate such office immediately the moneys owing by our Company to the Corporation is paid off or the Corporation ceasing to hold debentures shares in our Company or on the satisfaction of the liability of our Company arising out of any guarantee furnished by the Corporation



- d) The Nominee Director/s appointed under this articles shall be entitled to receive all notices of the attend all general Meetings, Board Meeting and Meetings of Committee of which the Nominee director's is/are Member/s as also be entitled to received all such notices and minutes.
96. Every Director, shall be paid a sitting fee (not exceeding such sum as may be prescribed by the Act or the Central Government from time to time) as may be decided by the Board for each meeting of the Board of Directors attended by him and shall be paid in addition thereto all traveling, hotel and other expenses properly incurred by him in attending and returning from the meetings of the Board of Directors or any Committee thereof or General Meeting of our Company or in connection with the business of our Company to and from any place.
97. If any Director being willing, shall be called upon t perform extra services or to make any special exertions in going or residing away from the town in which Registered Office of our Company may be situated for any purpose of our Company or in giving special attention to the business of our Company or as a member of the Board, then subject to sections 198, 309, 310 and 314 of the Act the Board may remunerate the Director so doing either by fixed sum or by a percentage of profits or otherwise and such remuneration may be either in addition to or in substation for any other remuneration to which he may be entitled.
98. The continuing Directors may act notwithstanding any vacancy in Board but if and so long as their number is reduced below three, the continuing Directors or Directors or Director may act for the purpose of increasing the number of Directors to three or of summoning a general Meeting of our Company , but for no other purpose.
99. a) Subject to the provisions of the Act the Directors including the Managing Director, if any, shall not be disqualified by reason of their office as such from contracting with our Company either as vendor, purchaser, lender, agent, broker or otherwise nor shall any contract or arrangement entered into by or on behalf of our Company with any Director, the Managing Director or with any Company or Partnership in which any Director or Managing Director shall be a member or otherwise interested be avoided nor shall any Director or the Managing Director so contracting or being such member or so interested be liable to account to our Company for any profit realized by such contract or arrangement by reason only of such Director or the Managing Director holding that office or of the fiduciary relation thereby established but the nature of the interest must be disclosed by him or them at the meeting of the Board at which he contract or arrangement is determined if the interest then exists or in any other case at the first meeting of the Board after the acquisition of the interest.

Provided nevertheless on Director shall take part in the discussion of or vote, as a Director in respect of any contract or arrangement in which he is so interested as aforesaid and if he does so his vote shall not be counted but he shall be entitled to be present at the meeting during the transaction of the business in relation to which he is precluded from voting although he shall not be counted for the purpose of ascertaining whether there is a quorum of Directors present. This provision shall not apply to any contract by or on behalf of our Company to give to the Directors or the Managing Director or any of them any security by or indemnity against any loss which they or any of them suffer by becoming or being sureties for our Company or to any contract or arrangements entered into or to be entered into with a public company, or a private company which is a subsidiary of a public company, in which the interest of the Director aforesaid consists solely on his being a Director of such Company and the holder of not more than shares of such number or value therein as is requisite to qualify him for appointment as a Director thereof, he having been nominated as such Director by his Company or in his being a member holding not more than 2% of its paid up shares capital.

- b) A General Notice that any Director is a Director or member of any specified company or a member of any specified firm and is to be regarded as interested in any subsequent transaction, with such Company or firm shall as regards any such transaction be sufficient disclosure under this article and after such General Notice it shall not be necessary to give any special notice relating to any particular transaction with such Company of Firm.



- c) A Director may be or become, a Director or member of any Company promoted by this Company or in which this Company may be interested as Vendor, Shareholder or otherwise and no such Director shall be accountable to our Company for any benefits received as a Director or Member of such Company.

#### ROTATION OF DIRECTORS

100. a) Note less than two thirds of the total number of the Directors of our Company for the time being holding office shall be directors whose period of office is liable to be determined by retirement by rotation and who shall be appointed by our Company in General Meeting.
- b) At each Annual General Meeting of our Company one third of such of the Directors as are liable to retire by rotation for the time being or if their number is not three or multiple of three, then the number nearest to one third shall retire from office An Additional Director appointed by the Board under Article 92 shall not be liable to retire by rotation within the meaning of this Article.
101. A retiring Director shall be eligible for reelection and our Company at the Annual General Meeting at which a Director retires in the manner aforesaid may fill up the vacated office by electing a person thereto.
102. The Directors to retire in every year shall be those who have been longest in office since their last election but as between persons who become directors on the same day those to retire shall unless they otherwise agree among themselves be determined by lot.
103. Subject to the provisions of Section 256 of the Act, if at any meeting at which an election of directors ought to take place the place of the vacating directors is not filled up and the meeting has not expressly resolved not to fill up the vacancy, the meeting shall stand adjourned till the same day in the next week at the same time and place or if that day is a public holiday till the next succeeding day which is not a public holiday at the same time and place and if at the adjourned meeting the place of retiring Directors is not filled up and that meeting has also not expressly resolved not to fill up the vacancy then the retiring directors of such of them as have not had their places filled up shall be deemed to have been re-appointed at the adjourned meeting.
104. Notwithstanding anything contained in these articles or in any agreement between any Director and our Company, subject to the provision of section 284 of the Act, our Company may by an ordinary resolution in general Meeting remove any Director before the expiration of his period of office, and may by an ordinary resolution appoint another person instead; the person so appointed shall be subject to retirement at the same time as if he had become a Director on the day on which the Director in whose place he is appointed was last elected as Director.
105. A person not being a retiring Director shall be eligible for appointment to the office of a Director at any General Meeting if he or some other member intending to propose him as a Director not less than 14 days before the meeting has left at the office of our Company a notice in writing under his hand signifying his candidature for the office of the Director or the intention of such member to propose him as a candidate for that office, as the case may be along with a deposit of Rs.500/- which shall be refunded to such person or as the case may be, to such member, if the person succeeds in getting elected as Director. intending to propose him as a Director.

#### PROCEEDINGS OF THE BOARD OF DIRECTORS

106. 1) Board of Directors shall meet at least once in every three calendar months for the dispatch of business, adjourn and otherwise regulate its meeting and proceedings as it thinks fit provided that at least four such meetings shall be held in every year.
- 2) The Managing Director may at any time summon a meeting of the Board and the Managing Director or the Secretary of the requisition of a Director shall at any time summon a meeting of the Board Notice in writing of every meeting of the Board shall be given to every Director for the time being in India. And at his usual address in India to every other director.
107. The quorum for a meeting of the Board shall be 1/3rd of the total strength (any fraction contained in that 1/3rd being rounded off as one) or two Directors whichever is higher. Provided that where at any



time the number of interested Directors is equal to or exceeds 2/3rd of total strength, the number of remaining Directors, that is to say, the number of Directors who are not interested present at the meeting being not less than two shall be the quorum during such time. The total strength of the Board shall mean number of Directors actually holding offices as Directors on the date of the resolution or meeting, that is to say, the total strength of the Board after deducting there from the number of Directors, if any whose places are vacant at the time.

108. 1) Save as otherwise expressly provided in the Act, a meeting of the Board for the time being at which quorum is present shall be competent to exercise all or any of the authorities power and discretions, by or under the regulations of our Company for the time being vested in or exercisable by the Directors and all questions arising at any meeting of the board shall be decided by a majority of the Board.
- 2) In case of an equality of votes, the Chairman shall have a second or casting vote in addition to his vote as a Director.
109. 1) The Board may elect a Chairman and vice Chairman of its meeting and determine the period for which they are to hold office.
- 2) If no such Chairman or Vice Chairman is elected or if at any meeting the chairman or vice chairman is not present within 5 minutes after the time appointed for holding the meeting, the Directors present may choose one of the number to be Chairman of the meeting.
- 3) If no such Chairman is elected or if at any meeting the chairman is not present within five minutes after the time appointed for holding the meeting, the Vice Chairman if elected and is present, the shall act as the chairman at the Meeting.
110. 1) The Board, may subject to the provisions of the act, delegate any of its powers to committees consisting of such member or members of its body as it thinks fit.
- 2) Any committees so formed shall in exercise of the powers so delegated conform to any regulations that may be imposed on it by the Board.
111. 1) If the Chairman of the Board is a member of the Committee, he shall preside over all meetings of the Committee if the chairman is not a member thereof, the committee may elect a Chairman of its meeting. If no such chairman is elected or if at any meeting the Chairman is not present within five minutes after the time appointed for holding the meeting the members present may choose one of their number to be chairman of the meeting.
112. 1) A committee may meet and adjourn as it thinks proper.
- 2) Questions arising at any meeting of a committee shall be determined by the sole member of the committee or by a majority of votes of the members present as the case may be and in case of an equality of votes, the chairman shall have a second or casting vote in addition to his vote as a member of the Committee.
113. All acts done by any meeting of the Board or of a Committee thereof or by any person acting as a Director shall notwithstanding that it may be afterwards discovered that there was some defect in the appointment of any one or more of such Directors or any person acting as aforesaid or that they or any of them were disqualified be as valid as if every such Director, such person had been duly appointed and was qualified to be a Director.
114. Save as otherwise expressly provided in the Act, a resolution in writing circulated in draft together with necessary papers, if any to all the Directors or to all the members of the Committee then in India, not being less in number than the quorum fixed for the meeting of the Board or the Committee, as the case may be and to all other Directors or Members at their usual address in India and approved by such of the Directors or Members at their usual address in India and approved by such of the Directors as are then in India or by a majority of such of them as are entitled to vote on the resolution shall be valid and effectual as if it had been a resolution duly passed at a meeting of the Board or committee duly convened and held.



## POWER & DUTIES OF DIRECTORS

115. The Business of our Company shall be managed by the Board of Directors, who may exercise all such powers of our Company, as are authorized by the act, or statutory modification thereof for the time being in force, except those by these presents, required to be exercised by our Company in General Meeting Provided in exercising any powers or doing any such act or thing the Board shall be subject to the provisions contained in that behalf in the Act or another provision of law or the Memorandum of Articles or any regulation not being inconsistent with the aforementioned, as may be prescribed in general Meeting. But no regulation made by our Company in General Meeting shall invalidate any prior act of the Board which would have been valid if that regulation had not been made.
116. Without prejudice to the general powers conferred by the last proceeding article and so as not in any way to restrict or limit these powers, and subject to the provisions of sections 58A, 292 and 293 of the act, the Board may, from time to time, at its discretion by resolution passed at a meeting of the Board, raise or borrow or secure the payment of any sum or sums of money for the purpose of our Company. Provided however that the Board shall not, without the sanction of our Company in General Meeting borrow any sum of money which together with moneys already borrowed by our Company (apart from temporary loans obtained from the Companies Bankers in the ordinary course of business) will exceed the aggregate for the time being of the paid-up Capital of our Company and its free reserves, that is to say reserves, not set aside for any specific purpose.
- The Board may, subject to the provisions of the Act, secure the repayment of such sum or sums in such manner and upon such terms and conditions in all respects as it think fit, and in particular, by the issue of bonds, perpetual or redeemable debentures or debenture - stock, or any mortgage or other security on the undertaking of the whole or any part of the property of our Company (both present and future) including its uncalled Capital for the time being.
- Any debentures, debenture-stock, bonds or other securities may be issued be at a discount, premium or otherwise and with any special privileges, as to redemption surrender, drawings, allotment of shares, appointment of Directors and otherwise. Debentures, debenture-stock, bonds and other Securities may be made assignable free from any equities between our Company and the person to whom the same may be issued. Provided however that the Debentures, debentures-stocks, Bonds other securities with a right to allotment of or conversion into shares shall not be issued except with sanction accorded by our Company in General Meeting, as prescribed by the Act.
117. If the Directors or any of them or any other persons, shall become personally liable for the payment of any sum primarily due from our Company, the Board may execute or cause to be executed any mortgage, charge or security over or affecting the whole or any part of the assets of our Company by way of indemnity to secure the Directors, or other persons so becoming liable as aforesaid from any loss in respect of such liability.
118. The Board may pay all expense incurred in getting up and registering our Company.
119. Our Company may exercise the powers conferred by section 50 of the Act with regard to having official seal for use abroad, and such powers shall be vested in the Board.
120. Our Company may exercise the power conferred by section 157 and 158 of the Act with regard to the keeping of a foreign register; and the Board may (subject to the provisions of the Act) make such regulations as they may think fit respecting the keeping of any such register.
121. All Cheques, promissory notes, drafts, hundies, bill of exchange and other negotiable instruments and all receipts for money paid to our Company shall be signed, drawn, accepted, endorsed or otherwise executed, as the case may be, in such manner as the Directors shall from time to time by resolutions determine.
122. Any branch or kind of business which our Company is authorised to undertake may be undertaken by the Directors at such time to times as they shall think fit, and further may be deferred them to be in advance, whether such branch of business may have been actually commenced or not so long as the Directors may deem it expedient not commence or proceed with the same.



123. Subject to the provisions of Sec.292 of the Act , the Board of Directors from time to time and at any time may delegate to any Director or Directors (by whatever designation) or attorney or officer any of the powers, authorities, discretion for the time being vested in the Directors and such delegation any be made on such terms and subject to such condition including power to sub-delegate as the Board may think fit and the Directors many from time to time revoke, withdraw, after or vary all or any such delegation.
124. 1) The Board of Directors shall exercise the following powers on behalf of our Company only by resolutions passed at the meeting of the Board.
- a) Power to make calls on shareholders in respect of moneys unpaid on meeting their shares;
  - b) Power to issue debentures;
  - c) Power to borrow moneys otherwise than on debentures;
  - d) Power to invest the funds of our Company ;
  - e) Power to make loans;
- 2) The Board of Directors may be a meeting delegate to any committee of the Directors or to Managing Director the Powers specified in sub-clauses (c), (d) and (e) above.
- 3) Every resolution delegation the power set out in sub-clause (c) above shall specify the total amount up to which money may be borrowed by the said delegate.
- 4) Every resolution delegating the Power referred to in sub-clause (d) above shall specify the total amount upto which the funds may be invested and the nature of the investment which may be made by the delegate.
- 5) Every resolution delegation the power referred top in sub-clause (e) above shall specify the total amount upto which the loans may be made by the delegate the purposes for which the loans may be made and the maximum amount of loans which may be made for each such purpose individual cases.

#### **MANAGING A DIRECTOR / WHOLE TIME DIRECTOR.**

125. a) Subject to the provisions of Section 197A,198,269, 316 and 317 of the Act, the Board may from time to time appoint one or more of their body to the office of Managing Director(s) or whole time directors(s) (by whatever designation) for such term and on such remuneration (whether by way of salary or commission or partly in one and partly in another) as they think fit and a director so appointed shall no, while holding that office be subject to retirement by rotation but the appointment shall be subject to determination IPSOFACTO if he ceases, due to any cause, to be a Director of our Company or if our Company in General Meeting resolves his tenure of the office of Managing Director of whole time director be determined.
- b) The Managing Director shall have such powers as the Board may delegate (without prejudice to Sec 292 of the Act) including the general discretion, management, and supervision of the business of our Company with full powers to all acts, matters and things deemed necessary, proper or expedient for carrying on the business or concerns of our Company and to exercise all powers, authorities and discretions of our Company , except only such of them as by the Act, or these presents directed to be exercised by the Directors in Board meetings or by the shareholders in General Meeting.

#### **COMMON SEAL**

126. a) The Board shall provide a common seal for the purposes of our Company and shall have power from time to time to destroy the same and substitute a new seal in lieu there of the Board shall provide for the safe custody of the seal for the time being, and the seal never be used except by the authority of the Board previously given.
- b) Our Company shall also be at liberty to have an official seal in accordance with section 50 of the Act, for use in any territory, district or place outside India.



127. Every Deed or other instrument, to which the seal of our Company is required to be affixed, shall, unless the same is executed by a duly constituted attorney, be signed by two Directors or one Director and Secretary or some other person appointed by the Board for the purpose. Provided that in respect of the share certificate the seal be in accordance with the Companies ( Issue of Share Certificate) Rules, 1960.

#### **DIVIDENDS AND RESERVES**

128. a) Subject to the rights of persons, if any, entitled to shares with special rights as to dividends, all dividends shall be declared and paid according to the amounts paid or credited as paid on the shares in respect whereof, the dividend is paid, but if and so long as nothing is paid upon any of the shares in our Company dividends may be declared and paid according to the amounts of the shares.
- b) Where capital is paid up on any shares in advance of call upon the footing that the same shall carry interest, such capital shall not, whilst carrying interest, confer a right to participate in profits.
129. Our Company in General Meeting may declare dividends but no dividend shall exceed the amount recommended by the Board.
130. The Board may from time to time pay to the members such interim dividends as appear to them to be justified by the profits of our Company .
131. 1) The Board may before recommending any dividends set aside out of the profits of our Company such sums as it thinks proper as a reserve or reserves which shall at the discretion of the Board, be applicable for any purpose to which the profits of our Company may be properly applied including provisions for meeting contingencies or for equalising dividends and pending such application, may at the like discretion either be employed in the business of our Company or be invested in such investments (other than shares of our Company ) as the Board may, from time to time think fit.
- 2) The Board may also carry forward any profits when it may think prudent not to divide, without setting them aside as Reserves.
132. The Board may deduct from any dividend payable to any members all sums of money, if any, presently payable by him to our Company on account of calls or otherwise in relation to the shares of our Company .
133. 1) Any dividend, interest or other moneys payable in cash in respect of shares may be paid by Cheque or warrant sent through post direct to the registered address of the holders or in the case of joint holders who is first named on the register of members or to such person and to such address as the holder or joint holders may in writing direct.
- 2) Every such Cheque or warrant shall be made payable to the order of the person to whom it is sent.
134. Any one of two or more joint holders of a share may give effectual receipt for any dividends, bonuses or other moneys payable in respect of such shares.
135. Notice of any dividend that may have been declared shall be given to the persons entitled to share thereto in the manner mentioned in the Act.

#### **136. UNPAID OR UNCLAIMED DIVIDEND:**

Where our Company has declared a dividend but which has not been paid or the dividend warrant in respect thereof has not been posted within 30 days from the date of declaration to any shareholder entitled to the payment of the dividend, our Company shall within 7 days from the date of expiry of the said period of 30 days, open a special account in that behalf in any scheduled bank called " Unpaid Dividend of Chemcel Bio Tech Limited" and transfer to the said account, the total amount of dividend which remains unpaid or in relation to which no dividend warrant has been posted.



Any money transferred to the unpaid dividend account of our Company which remains unpaid or unclaimed for a period shall be dealt as per the provisions of the companies act 1956.

No unclaimed or unpaid dividend shall be forfeited by the Board.

#### **CAPITALISATION OF PROFITS.**

138. 1) Our Company in General Meeting may on recommendation of the Board, resolve;
- a) That it is desirable to capitalize any part of the amount for the time being standing to the credit of our Company 's reserve accounts or to the credit of the profit and loss account otherwise available for distribution; and
  - b) That such sum be accordingly set free for distribution in the manner specified in sub clause (2) amongst the members who would have been entitled thereto, if distributed by way of such dividend and in the same proportions.
- 2) The sum aforesaid shall not be paid in cash but shall be applied, subject to the provisions contained in sub clause (3) either in or towards;
- i) Paying up any amounts for the time being unpaid on shares held by such members respectively;
  - ii) Paying up in full, unissued shares of our Company to be allotted and distributed, credited as fully paid up to and amongst such members in the proportions aforesaid, or
  - iii) Partly in the way specified in sub-clause (i) and partly in that specified in sub-clause(ii).
- 3) A share premium account and a capital redemption reserve account may, for the purpose of this regulation only, be applied in the paying up of un-issued shares to be issued to members of our Company as fully paid bonus shares.
- 4) The Board shall give effect to the resolutions passed by our Company in pursuance of this regulations.
139. 1) Whenever such resolution as aforesaid shall have been passed the Board shall;
- a) make all appropriations and application of the undivided profits bonus to be capitalized thereby and all allotments and issue of fully paid shares, if any, and;
  - b) generally do all acts and things required to give effect thereto.
- 2) The Board shall have power.
- a) To make such provision, by the issue of fractional certificates or by payments in cash or otherwise as it thinks fit, in the case of shares of debentures becoming distributable in fraction; and also.
  - b) To authorise any person to enter on behalf of all the members entitled thereto into an agreement with our Company providing for the allotment to them respectively credited as fully paid up of any further shares to which they may be entitled upon such capitalization or (as the case may require) for the payment of our Company on their behalf, by the application thereto of the respective proportions of the profits resolved to be capitalized of the amounts or any part of the amounts remaining unpaid on the shares.
- 3) Any agreement made under such authority shall be effective and binding on all such members.

#### **BOOKS OF ACCOUNTS**

140. a) Our Company shall keep at the office or such other place in India as the Board thinks fit proper Books of Account in accordance with section 209 of the Act.
- b) Where the Board decides to keep all or any of the Books of Accounts at any place other than the office of our Company, shall within seven days of the decision file with the Registrar a notice in writing giving the full address of that place.





- c) Where our Company as a branch office, whether in or outside India, our Company shall be deemed to have complied, with this Article if proper Books of account relating to the transactions effected at the branch office are kept at the branch office and proper summarized returns, made up to date at intervals of not more than three months, are sent by the branch office to our Company at its office or other place in India, at which our Company 's Books of Accounts are kept as aforesaid.

141. The Board of Directors shall from time to time determine whether and to what extent and at what times and place and under what conditions or regulations the accounts and books and documents of our Company or any of them shall be open to the inspection of the members, and no member (not being a Director) shall have any right of inspecting any account or books of accounts or documents, or our Company except as conferred by statute or authorised by the Directors of by a resolution of our Company in General Meeting.

#### AUDIT

142. Every Balance sheet and Profit and Loss Account of our Company shall be audited by one or more auditors. The auditors shall be appointed their remuneration shall be fixed, their rights duties and liabilities shall be regulated and their qualifications and disqualifications shall be in accordance with the provisions of Section 224 to 233 inclusive of the Act.

#### SERVICE OF DOCUMENTS AND NOTICE.

143. A document may be served on our Company or an officer thereof by spending it to our Company or officer at the registered office of our Company by post under a certificate of posting or by registered post, or by leaving it at its registered office.

144. 1) A document, (which expression for this purpose shall be deemed to include and shall include any summons, notice, requisition, process order, judgement, or any other documents in relation to or in the winding up of our Company ) may be served or sent by our Company on or to any member either personally or by sending it by post to him to his registered address, in India or (if he has no registered address in India) to the address, if any within India supplied by him.

2) All notices shall, with respect to any registered shares to which persons are entitled jointly, be given to whichever of such person is named first in the register and notice so given shall be sufficient notice to all the holders of such share.

3) Where a document is sent by post;

a) Service thereof shall be deemed to be effected by properly addressing prepaying and posting a letter containing the notice, provided that where a member has intimated to our Company in advance that documents should be sent to him under a certificate of posting or by registered post without acknowledge due and has deposited with our Company sum sufficient to defray the expenses of doing so, service of the documents shall not be deemed to be effected unless it is sent in the manner intimated by the member; and

b) Unless the contrary is proved, such service shall be deemed to have been effected.

i) In the case of notice of meeting at the expiration of forty eight hours after the letter containing the notice is posted; and

ii) In any other case at the time at which the letter would be delivered in the ordinary course of post.

145. Each registered holder of shares shall from time to time notify in writing to our Company some place in India to be registered as his address and such registered place of address shall for all purposes be deemed his place of residence.

146. If a member has not registered an address in India, and has not supplied to our Company an address within India, for the giving of notices to him, a document advertised in a newspaper circulating in the neighbour-hood of registered office of our Company shall be deemed to be duly served on him on the day on which advertisement appears.

147. A document may be served by our Company on the persons entitled to a share in consequence of the



death or insolvency of member by sending in through the post in a prepaid letter addressed to them by name or by the title or representative of the deceased or assignees of the insolvent or by any like description at the address (if any) in India supplied for the purpose by the persons claiming to be so entitled, or (until such an address has been so supplied) by serving the document in any manner in which the same might have been served if the death or insolvency had not occurred.

148. Subject to the provisions of the Act, any document required to be served or sent by our Company on or to the members, or any of them and not expressly provided for by these presents, shall be deemed to be duly served or sent if advertised in a newspaper circulating in the district in which the registered office is situated.
149. Every person, who by the operation of law, transfer, or other means whatsoever shall become entitled to any share shall be bound by every document in respect of such share which, previously to his name and address being entered on the register, shall have been duly served on or sent to the person from whom he derived his title to such share.
150. Any notice to be given by our Company shall be signed by the Managing Director or by such Director or Officer as the Directors may appoint. The signature to any notice to be given by our Company may be printed or lithographed.

#### **INDEMNITY AND A RESPONSIBILITY.**

151. a) Subject to the provisions of Section 201 of the Act, every Director, Secretary and other Officer or employee of our Company shall be indemnified by our Company against any liability, and it shall be the duty of Directors out of the funds of our Company to pay all costs and losses and expenses (including traveling expenses) which any such Director, Officer or Employee may incur or become liable to by reason of any contract entered into or act or deed done by him as such Director, Officer or Employee or in any way in the discharge of his duties.
- b) Subject as aforesaid every Director, Secretary or other Officer or employee of our Company shall be indemnified against any liability incurred by them or him in defending any proceedings whether civil or criminal in which judgment is given in their or his favour or in which he is acquitted or discharged or in connection with any application under section 633 of the Act in which relief is given to him by the court.
152. 1) Subject to the provisions of Section 201 of the Act, no Director or other Officer of our Company shall be liable for the acts, receipts, neglects or defaults or any other Director or Officer or for joining in any receipt or other act for conformity or for any loss or exposed happening to our Company through insufficiency or deficiency of title to any property acquired by order of the Directors for or on behalf of our Company, or for the insufficiency or deficiency of any security in or upon which any of the moneys of our Company shall be invested, or for any loss or damage arising from the bankruptcy insolvency or tortious act of any person, company or corporation, with whom any moneys, securities or effects shall be entrusted or for any loss occasioned by any error of judgment or oversight on his part or for any other loss damage or misfortune whatsoever which happen in the execution of the duties of his office or in relation thereto, unless the same happen through his own willful neglect, act or default.

#### **SECURITY CLAUSE.**

153. No member or other person (not being a Director) shall be entitled to inspect our Company's works without the permission of the Directors or Managing Director or to require discovery of or any information respecting any detail of our Company's trading or any matter which is or may be in the nature of a trade secret, mystery of trade, secret process which in the opinion of the Director it will be expedient in the interests of the public to communicate to the public.
154. Every Director, Managing Director, Manager, Secretary, Auditor, Trustees Members of a Committee, Officer, Servant, Agent, Accountant or other person employed in the business of our Company, shall if so required by the Directors before entering upon his duties, or at any time during his term of office, sign a declaration pledging himself to observe strict secrecy respecting all transactions of our Company and the state of accounts and in matters relating thereto, and shall by such declaration pledge himself not to reveal any of the matters which may come to his knowledge in the discharge of his duties except when required to do so by the Directors or any meeting or by a court of law or by the person to whom such matters relate and except so far as may be necessary in order to comply with any of the provisions of these articles or law.



## SECTION X: MATERIAL CONTRACTS AND DOCUMENTS FOR INSPECTION

The following contracts and agreements referred to in Para "A" below (not being contracts entered into in the ordinary course of business carried on or intended to be carried on by our Company or contracts entered into more than two years before the date of this Prospectus) which are / or may be deemed to be material have been entered into by or on behalf of our Company. Copies of these contracts together with copies of documents referred to in Para "B" below all of which have been attached to the copy of this Prospectus and which have been delivered to the ROC for registration and may be inspected at the Registered Office of our Company between 11.00 a.m. and 1.00 p.m. on any working day from the date of this Prospectus until the date of closing of subscription list

### A MATERIAL CONTRACTS

1. Engagement letter dated June 18, 2007 appointing Allbank Finance Limited as the lead manager to the issue
2. Memorandum of Understanding (MOU) dated 1st July 2007 between our Company and M/S AllBank Finance Limited. the Lead Manager to this Issue .
3. Memorandum of Understanding (MOU) dated December 29,2007 between our Company and M/S Ashika Capital Limited, the Co Lead Manager to this Issue .
4. Memorandum of Understanding (MOU) dated 15th November, 2006 between our Company and the Registrar to the Issue ie. Bigshare Services Pvt. Limited.
5. Inter -se allocation of responsibilities between the Lead Maanger and the Co Lead Manager

### B DOCUMENTS FOR INSPECTION

1. Memorandum and Articles of Association of our Company as amended from time to time.
2. Certificate of Incorporation dated September 29, 1995 and certificate of commencement of business dated 27th October 1995, obtained from Registrar of Companies, Andhra Pradesh.
3. Fresh certificate of incorporation dated January 04 , 2001 obtained from Registrar of Companies, Andhra Pradesh consequent to change of name from Chemcel Products Limited to Chemcel Bio-Tech Limited
4. Copy of special resolution passed by Board of Directors of our Company at their meeting held on July 20,2008 and by shareholders u/s 81 (1A) at their Extra Ordinary General Meeting held on August 14,2008 authorising the Issue of Equity Shares
5. Copies of the Service Agreement entered into with the Executive Chairman, Managing Director and Director (Production).
6. Annual reports of our Company for the years ended March 31, 2004, 2005, 2006, 2007 and 2008.
7. Report of our Statutory Auditor T.Nehru, Chartered Accountant dated July 12, 2008 on financial statements in the Prospectus and copies of the Annual Reports mentioned in the Report.
8. Statutory Auditors Report on tax benefits dated July 12, 2008.
9. Consent letters from Directors, Lead Manager, Co- Lead Manager to the Issue, Bankers to the Issue, Bankers to our Company , Auditors to our Company , Legal Advisor to the issue, Registrar to the Issue, Company Secretary & Compliance Officer and IPO Grading Agency in this case being ICRA Limited to act in their respective capacities and for inclusion of their names in the Prospectus.
10. Consent by the auditor for inclusion of his report dated July 12, 2008.
11. Copy of Board Resolution passed on December 02 , 2005 for appointment of Mr. Kanupathi Balakrishna Rao as Executive Chairman; Mr. Kanupathi Trinatha Vijay Kumar as Managing Director and Mr. Kanupathi Chandra Sekhar Prasad as Director (Production) and the remuneration to be payable to them.



12. Copy of Court order Issued by the II<sup>nd</sup> Addl. Senior Civil Judge, Vijayawada dated 5<sup>th</sup> March, 2007.
13. Due diligence certificate dated December 29,2007 issued by AllBank Finance Limited, the Lead Manager to the Issue,
14. Statutory Auditors certificate dated August 18, 2008 regarding sources and deployment of funds as on August 18, 2008.
15. Copy of the Board Resolution approving the Final Prospectus dated 29th August, 2008.
16. Copies of letters received from Union Bank of India, vide their letters dated 8th November, 2006 and 23rd May 2007 sanctioning term loan and working capital facility respectively.
17. SEBI observation letter No. CFD/DIL/PB/EHM/128458/2008 dated June 12, 2008,
18. Copy of agreement dated May 25, 2007, with M/s Jetro Petro Biotech Private Limited for procurement of raw material including Jatropha Seeds, Pongamia, Neem, Palm oil seeds, cotton seeds and all such of the kinds of seeds.
19. Copy of Application ref: AllBank/CBL/IPO of December 31, 2007 made to Bombay Stock Exchange Ltd seeking for in-principle approval for listing the company's shares on BSE.
20. Copy of In principle listing approval no.DCS/IPO/SI/IPO-IP/1823/2007-08 dated February 08,2008 received from BSE.
21. Copy of IPO Grading Certificate issued by the grading agency, ICRA Ltd vide its letter ref: ICRA/CBL/2008-09/2006 dated June 25, 2008 and revalidation letter no ICRA/CBL/2008-09/2208 dated August 22,2008.
22. Copy of tripartite agreement dated March 11, 2008 between NSDL, our Company and Bigshare Services Private Ltd.
23. Copy of tripartite agreement dated March 4, 2008 between CDSL, our Company and Bigshare Services Private Ltd.
24. Certificates dated February 06, 2008 of M/S Arun Patibanda, independent Auditor with regard to utilisation of short term loan and Working capital loans from Union Bank of India, Vijayawada.
25. Certificate from AllBank Finance Limited, Lead Manager and the correspondence with Mr. Chaperia on various dates.
26. In seriatim reply of AllBank Finance Limited vide letter dated August 27,2008.



## DECLARATION

We, the Directors of the Company, certify that all relevant provisions of the Companies Act, 1956, and the guidelines issued by the Government of India or the guidelines issued by Securities and Exchange Board of India, applicable, as the case may be, have been complied with and no statement made in this Prospectus is contrary to the provisions of the Companies Act, 1956, the Securities and Exchange Board of India Act, 1992 or the rules made thereunder or guidelines issued, as the case may be, and that all approvals and permissions required to carry on our business have been obtained, are currently valid and have been complied with. We further certify that all the statements in this Prospectus are true and correct.

## SIGNED BY DIRECTORS OF OUR COMPANY

Sr. No.	Name of The Director	Designation	Signature
1	<b>Mr. Kanuparthi Balakrishna Rao</b>	Chairman & Whole Time Director	
2	<b>Mr. Kanuparthi Trinatha Vijaya Kumar</b>	Managing Director	
3	<b>Mr. Kanuparthi Chandra Shekhar Prasad</b>	Whole Time Director	
4	<b>Mr. Dhulipala Sankar</b>	Director	
5	<b>Mr. Polamraju Narasimha Murthy</b>	Director	
6.	<b>Mr. Koka Shri Hari Rao</b>	Director	

Signed by Mr. SHAIK RAHAMATULLAH, Company Secretary & Compliance Officer

Place: Mumbai

Date: 29th August, 2008